

# **XV8031D**

## **Self-Contained Leaf Vacuum**



**Owner's Manual  
Safety Manual  
Pre-Operating Manual  
Operating Manual  
Maintenance Manual  
Service Manual  
Parts Catalog**

Sold and Serviced by:

**[www.xtremevac.com](http://www.xtremevac.com)**

812220

 **CAUTION**

**DO NOT ATTEMPT TO OPERATE  
OR REPAIR  
THE LEAF COLLECTOR WITHOUT FIRST  
READING AND UNDERSTANDING THIS  
MANUAL**

IF YOU HAVE ANY QUESTIONS CONCERNING THE  
INSTALLATION OR OPERATION OF THIS UNIT, PLEASE CALL  
ODB FOR ASSISTANCE BEFORE ATTEMPTING TO REPAIR OR  
OPERATE THE UNIT.

**IMPROPER USE OF ANY MACHINE CAN  
RESULT IN INJURY!**

**STUDY AND FOLLOW ALL SAFETY  
PRECAUTIONS BEFORE OPERATING OR  
REPAIRING UNIT**

THIS MANUAL IS AN INTEGRAL PART OF THE LEAF COLLECTOR AND SHOULD  
BE KEPT WITH THE UNIT WHEN IT IS SOLD.

# Registration

Please take the time to register you leaf collector and your engine for warranty purposes.

You may go to our website: [www.xtremevac.com](http://www.xtremevac.com) to register your unit or use the warranty sheet below and mail to:

Attn: Xtreme Vac Registration  
Xtreme Vac  
5118 Glen Alden Drive  
Richmond, VA 23231

You may also fax the form to: (804) 226-6914.

For engine registration, please use the forms provided in your engine owner's manual.

## ODB LEAF COLLECTOR / RMB500 WARRANTY REGISTRATION

(Register your leaf vacuum or RMB500 to start your warranty)

\*\*\*Register online at [www.odbc.com/register.htm](http://www.odbc.com/register.htm)\*\*\*

Purchaser's Name \_\_\_\_\_

Department \_\_\_\_\_

MAILING Address \_\_\_\_\_

City \_\_\_\_\_ State/Province \_\_\_\_\_ Postal Code \_\_\_\_\_

Leaf Collector Serial Number     -

Leaf Collector VIN Number  1  Z  9  P         R  1  6  8

Date Delivered (mm/dd/yyyy) \_\_\_\_\_ / \_\_\_\_\_ / \_\_\_\_\_

ODB Leaf Collector/Sweeper Model Number (please check one)

XV6527  XV8027/31  Xtreme Sweep  XV6000  SCL65TM  Other: \_\_\_\_\_

Engine Manufacturer:  John Deere  Kawasaki  Cummins  Kubota  Other: \_\_\_\_\_

Engine Serial Number:

(example PE4045T123456, John Deere engines must have 13 characters)

Contact Name \_\_\_\_\_

Telephone (\_\_\_\_\_) \_\_\_\_\_ - \_\_\_\_\_

THANK YOU FOR PURCHASING AN Xtreme Vac!

Note: This form may be **faxed** to (804) 226-6914

The leaf collector owner's and safety manual was received. I understand that it is the responsibility of each user and mechanic to carefully read and understand the safety and operating sections of the owner's manual.

\_\_\_\_\_  
Purchaser's Signature

\_\_\_\_\_  
Date

# Registration



## WARNING

Read and understand this entire manual before operating, maintaining or repairing the leaf vacuum.

PLEASE RECORD THE FOLLOWING INFORMATION BEFORE  
PLACING THE UNIT INTO SERVICE:

Model Number: \_\_\_\_\_ Unit Serial No.: \_\_\_\_\_

Purchase Date: \_\_\_\_\_ Engine Serial No.: \_\_\_\_\_

# TABLE OF CONTENTS



**WARNING**

Read and understand this entire manual before operating, maintaining or repairing the leaf vacuum.

## Contents

### 1.0 GENERAL SAFETY

1.1 SAFETY SYMBOL DEFINITIONS: .....	9
1.2 DO'S AND DO NOT'S: .....	10
1.3 TRAINING: .....	12
1.4 Decal Listing: .....	13
1.4 SAFETY DECALS - Decal Layout for X-treme Vac.....	14
1.4 Decal Listing: Part Numbers .....	15

### 2.0 PRE-OPERATING SECTION

2.1 INSTRUMENTS AND CONTROLS: .....	17
2.1 INSTRUMENTS AND CONTROLS, cont.: .....	18
2.2 SAFE OPERATIONS:.....	19
2.2 SAFE OPERATIONS (continued): .....	20
2.3 PREPARATION FOR OPERATION.....	21
2.4 PRE-TRANSPORT CHECKS .....	22
2.4 PRE-TRANSPORT CHECKS (continued): .....	23
2.5 PERSONAL PROTECTIVE EQUIPMENT AND CLOTHING.....	24
2.6 WORK SITE PREPARATION.....	25

### 3.0 OPERATING SECTION

3.1 Starting Engine.....	27
3.1 Starting Engine, continued;.....	28
3.2 Engaging the Impeller .....	29
3.2 Engaging the Impeller, continued; .....	30
3.3 Dumping the Body .....	31
3.3 Dumping the body, continued; .....	32
3.3 Dumping the Body, continued;.....	33
3.4 Vacuuming Leaves .....	34

### 4.0 MAINTENANCE SECTION

4.1 MAINTENANCE OVERVIEW.....	36
4.2 MAINTENANCE AND LUBRICATION CHART.....	37
4.3 LUBRICATION:.....	38
4.3 LUBRICATION, continued; .....	39
4.3 LUBRICATION, continued; .....	40
4.3 LUBRICATION, continued; .....	41
4.4 PREVENTATIVE MAINTENANCE .....	42
4.4 PREVENTATIVE MAINTENANCE, continued;.....	43
4.4 PREVENTATIVE MAINTENANCE, continued;.....	44

# TABLE OF CONTENTS

## **WARNING**

Read and understand this entire manual before operating, maintaining or repairing the leaf vacuum.

44 PREVENTATIVE MAINTENANCE, continued; .....	45
45 TORQUE VALUES .....	46
<b>5.0 SERVICE SECTION</b>	
5.1 Belt Adjustment / Removal.....	48
5.1 Belt Drive Adjustment, continued; .....	49
5.2 Impeller Removal / Installation .....	50
5.2 Impeller Removal / Installation .....	51
5.3 Impeller Bearings Removal / Installation.....	52
5.4 Main Circuit Board Plug Diagram.....	53
5.5 Main Circuit Board Plug Diagram.....	54
5.6 Flow Control Valve Adjustment Instructions .....	55
5.7 Trailer Plug Wiring Diagram.....	56
5.8 Hoist Hydraulic Schematic.....	57
<b>6.0 PARTS BREAKDOWNS</b>	
6.1 Blower Housing Group.....	59
6.2 Instrument Panel Group.....	60
6.3 Engine and Engine Base Group.....	61
6.4 Belt Drive Group - Kubota .....	62
6.5 Belt Engagement Group .....	63
6.6 Kubota Engine Group.....	64
6.7 Tongue Group .....	65
6.8 Hydraulic Pump.....	66
6.8 Hydraulic Pump.....	67
6.9 PTO Group .....	68
6.10 Chassis and Axle Group .....	69
6.11 Hub and Brake Group.....	70
6.12 Box Container Group.....	71
6.13 Light and Reflector Group.....	72
6.14 Rear Door Hardware.....	73
6.15 Intake Hose Group.....	74
6.16 Dump Hoist Group .....	75

# SAFETY PRECAUTIONS

## WARNING

Read and understand this entire manual before operating, maintaining or repairing the leaf vacuum.

## 1.0 GENERAL SAFETY

### 1.0 GENERAL SAFETY

#### Contents

#### 1.0 GENERAL SAFETY

1.1 SAFETY SYMBOL DEFINITIONS: .....	9
1.2 DO'S AND DO NOT'S: .....	10
1.3 TRAINING: .....	12
1.4 Decal Listing:.....	13
1.4 SAFETY DECALS - Decal Layout for X-treme Vac .....	14
1.4 Decal Listing: Part Numbers.....	15

# SAFETY PRECAUTIONS

## WARNING

Read and understand this entire manual before operating, maintaining or repairing the leaf vacuum.



**DO NOT RIDE, SIT OR STAND  
ON UNIT.**

**RIDING ON UNIT  
COULD RESULT IN BODILY  
HARM OR FATAL INJURY  
USE EXTREME CAUTION WHEN  
UNIT IS IN USE, OR IN MOTION.**

If the decal above is missing or damaged call ODB immediately and we will send you a replacement free of charge. Never operate a unit with damaged or missing safety decals.

 **DANGER**

**DO NOT RIDE, SIT OR STAND ON UNIT**

 **DANGER**

**DO NOT MODIFY THE UNIT FOR RIDERS IN ANY  
WAY. SERIOUS INJURY OR DEATH MAY OCCUR**

ODB's leaf collectors are NEVER to be used to accommodate riders. If your unit has been modified to accommodate riders, remove these modifications immediately as this can result in serious injury or death.



# SAFETY PRECAUTIONS





## WARNING

Read and understand this entire manual before operating, maintaining or repairing the leaf vacuum.

### 1.1 SAFETY SYMBOL DEFINITIONS:

This manual provides the owners/operator with procedures for safe operation, maintenance and repair of your leaf collector. As with any machine, there are hazards associated with their operation. For this reason safety is emphasized throughout this manual. To highlight specific safety information the following safety definitions are provided to assist the reader.

The purpose of safety symbols are to attract your attention to possible dangers. The safety symbols, and their explanations, deserve your careful attention and understanding. The safety warnings do not by themselves eliminate any danger. The instructions or warnings they give are not substitutes for proper accident prevention measures.

SYMBOL	MEANING
	<b>SAFETY ALERT SYMBOL:</b> Indicates danger, warning or caution. Attention is required in order to avoid serious personal injury. May be used in conjunction with other symbols or pictographs.
	Disregarding this safety warning <b>WILL</b> result in serious equipment damage, injury or possible death.
	Disregarding this safety warning <b>CAN</b> result in serious equipment damage, injury or possible death.
	Disregarding this safety warning <b>MAY</b> result in minor or moderate injury or property damage.

# SAFETY PRECAUTIONS

## WARNING

Read and understand this entire manual before operating, maintaining or repairing the leaf vacuum.

## 1.2 DO'S AND DO NOT'S:

This section contains some general safety precautions to do and not to do. This is not an all inclusive list and it is the responsibility of the operator to have proper training and use common sense in work situations.

## WARNING

### DO NOT:

1. DO NOT operate, maintain or repair this unit without having fully read and understood ALL the aspects of this manual.
2. DO NOT ride, sit or stand on unit at anytime.
3. DO NOT modify the leaf vacuum for any reasons to allow for riders.
4. DO NOT operate the unit in a state of disrepair.
5. DO NOT operate the unit with ANY guards or safety devices broken, missing, or inoperable.
6. DO NOT operate the unit without wearing proper safety equipment.
7. DO NOT operate this unit while under the influence of any alcohol or medication.
8. DO NOT operate this unit if you have a record of mental instability or dizziness which could result in injury to yourself or others.
9. DO NOT operate this unit if you are under 18 years of age.
10. DO NOT operate this unit without fully inspecting the unit for any damage or leakage.
11. DO NOT operate if the unit has any excessive vibration.
12. DO NOT operate unit with the inspection door limit switch damaged or missing.
13. DO NOT tow unit without using all the safety chains.
14. DO NOT tow unit with a damaged tongue.
15. DO NOT fill fuel tank with engine running. Allow engine to cool for 5 minutes before refueling.
16. DO NOT operate unit if fuel is spilled or with fuel cap off.
17. DO NOT smoke or weld near the unit.
18. DO NOT run engine in an enclosed area.
19. DO NOT place hands or feet near moving or rotating parts.
20. DO NOT operate engine with an accumulation of grass, leaves or other debris on the engine.
21. DO NOT run engine with air cleaner removed.
22. DO NOT leave leaf machine unattended while in operation.
23. DO NOT park machine on steep grade or slope.
24. DO NOT vacuum a leaf pile without looking for foreign objects such as metal, glass, plastic or large pieces of wood.

# SAFETY PRECAUTIONS

## WARNING

**DO NOT, continued;**

### **DO's:**

1. DO completely read and understand the owner's manual before operating, maintaining or repairing the leaf collector.
2. DO follow engine and PTO manufacturer operating and maintenance instructions.
3. DO check fuel lines and fittings frequently for cracks or leaks. Replace if necessary.
4. DO completely inspect the unit before leaving the service garage.
5. DO check the tow tongue each day for cracks.
6. DO inspect and be attentive to what is being vacuumed.
7. DO check the impeller, liners and blower housing for cracks or holes daily.
8. DO remove the lead spark plug wires, if equipped, before doing any maintenance on the unit.
9. DO wear proper safety equipment as described in this manual.
10. DO watch for pedestrians, animals and other foreign material when vacuuming leaves.
11. DO replace any worn or missing safety stickers immediately.

## WARNING

## WARNING

Battery posts, terminals and related accessories contain lead and lead compounds, chemicals known to the state of California to cause cancer and birth defects or other reproductive harm. Wash Hands after handling

## WARNING

Engine Exhaust, some its constituents and certain vehicle components contain or emit chemicals known to the state of California to cause cancer and birth defects or other reproductive harm.

# SAFETY PRECAUTIONS

## 1.3 TRAINING:

### **WARNING**

**Improper use of the ODB leaf collector CAN result in severe personal injury or death. All personnel using this leaf vacuum must be trained and qualified with all the operations, maintenance, repair and safety procedures defined in this manual.**

The warnings and procedures regarding safety in this manual are to be used as a guideline only. It is impossible to cover all the events that could happen in the vacuuming process. For this reason, it is vital that the owner accept the responsibility to implement a training program that will provide every operator or mechanic the basic skills and knowledge to make good judgement in all situations.

This training program must include the entire scope of hazards, precautions and government regulations encountered in the vacuuming process. The program should stress the need for regularly scheduled preventive maintenance and detailed equipment safety checks.

ODB strongly recommends all training programs be documented to ensure all operators and mechanics receive initial training on not just the operation but the safety features of the leaf collector.

# SAFETY PRECAUTIONS

## 1.4 Decal Listing:

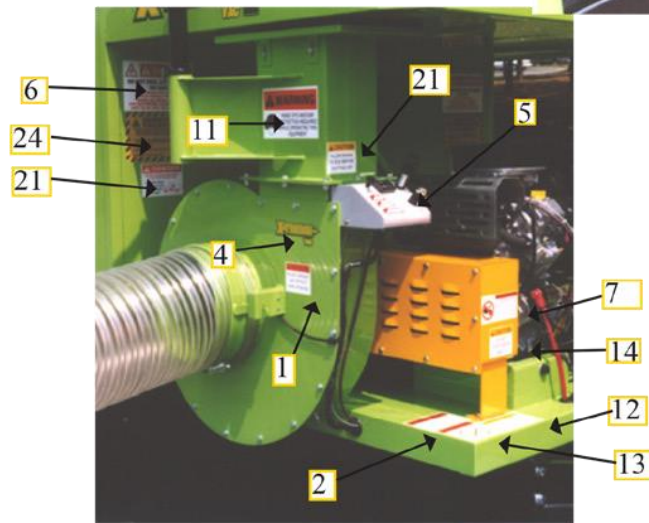
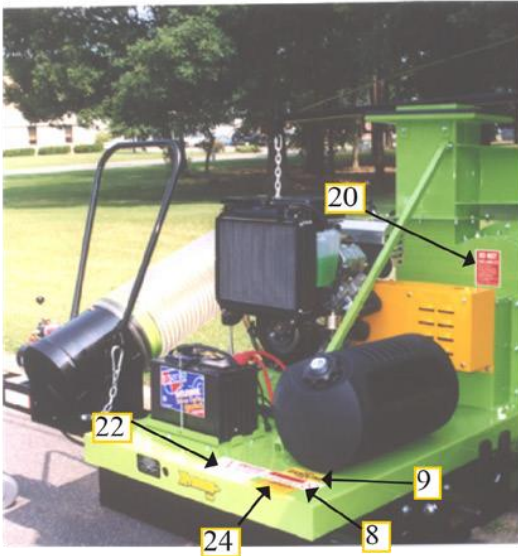

# SAFETY PRECAUTIONS

## 1.4 SAFETY DECALS - Decal Layout for X-treme Vac

1		9		18	
2		10		19	
3		11		20	
4		12		21	
5		13		22	
6		14		23	
7		15		24	
8		16		25	
		17		26	

# SAFETY PRECAUTIONS

## 1.4 Decal Listing: Part Numbers

### Decals shown on previous page

ITEM NO.	PART NUMBER	DESCRIPTION
1.	65.1801	Warning--Do Not Operate Unit Without Hose Attached
2.	200189	Warning--Check Imp. and Blwr Housing ...
3.	200182	Warning--Do Not Open Cover ... Operation
4.	65.1902	X-treme Vac -small
5.	65.1506	Instrument Panel Sticker
6.	200179	Danger--Do Not Sit, Ride or Stand on unit.
7.	200182	Warning--Do Not Open Cover ... Operation
8.	200177	Warning--Flammable
9.	200102	Use Gasoline Only
10.	65.1803	Caution--Allow Engine to Idle ...
11.	200181	Warning--Head, Eye and Ear Protection
12.	65.1800	Warning--Do Not Operate ...Manual
13.	200175	Warning--Do Not Raise Hoist...
14.	65.1802	XV6527 Sticker
15.	65.1903	X-treme Vac - large, RH
16.	65.1901	Warning--Head, Eye, Ear Protection
17.	200181	XV6527 Sticker
18.	200185	Operation of Body Prop
19.	200190	Caution--Unload Body
20.	200109	Do Not Overlubricate
21.	200188	Danger--Do Not go under body...
22.	200178	Danger--Explosion Hazard
23.	200183	Warning - Rotating Parts
24.	200187	Caution--Body prop must be braced
25.	200180	Danger--Remove Tow Bar...
26.	200104	Warning--Driver check wheel lugs

# PRE-OPERATING SECTION

## **WARNING**

Read and understand this entire manual before operating, maintaining or repairing the leaf vacuum.

## 2.0 PRE-OPERATING SECTION

**2.0  
Pre-Operating  
Section**

### 2.0 PRE-OPERATING SECTION

2.1 INSTRUMENTS AND CONTROLS:.....	17
2.1 INSTRUMENTS AND CONTROLS, cont.: .....	18
2.2 SAFE OPERATIONS: .....	19
2.2 SAFE OPERATIONS (continued): .....	20
2.3 PREPARATION FOR OPERATION.....	21
2.4 PRE-TRANSPORT CHECKS .....	22
2.4 PRE-TRANSPORT CHECKS (continued): .....	23
2.5 PERSONAL PROTECTIVE EQUIPMENT AND CLOTHING.....	24
2.6 WORK SITE PREPARATION.....	25



# PRE-OPERATING SECTION

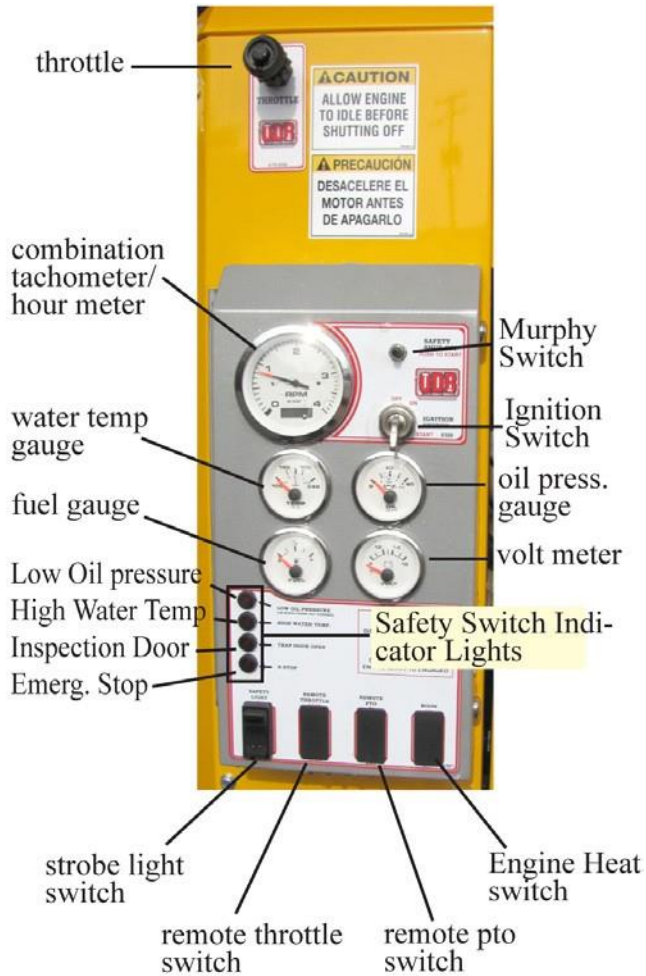

**Always make sure the PTO is disengaged before starting unit.**

## 2.1 INSTRUMENTS AND CONTROLS:

### Ignition Switch:

Used to power the accessories and start the unit. Unit will not start without Murphy switch depressed.

ACCESSORIES - first position

STARTER ENGAGE - second position (springs return to first position)

### Murphy Switch:

This switch overrides the low oil pressure and high temperature cutoff control. This switch must be depressed before the starter engages. After the engine starts, wait for oil pressure to rise before releasing the button.

### Throttle:

This control provides positive locking and vernier adjustment of engine.

### Combination Tachometer / Hour Meter:

This gauge indicates the engine r.p.m's. The sender is located on the tachometer. The hour meter is digital and indicates the accumulated hours of the engine. This should be used to schedule maintenance.

### Volt Meter:

The gauge shows the status of the engine charging system. When the charging system is operating properly it should read approximately 14 volts. If the gauge reads below 13 volts, the alternator is not charging the battery and the system should be checked by a qualified technician.

### Oil Pressure Gauge:

Confirms and indicates the presence and pressure of engine oil. If the gauge reads low, it should be checked by a qualified technician.

### Engine Temperature:

Indicates the engine coolant temperature. If the gauge reads over 240 degrees the unit should be checked by a qualified technician.

### Hour Meter:

Indicates the accumulated hours of the engine. This should be used to schedule maintenance.

# PRE-OPERATING SECTION

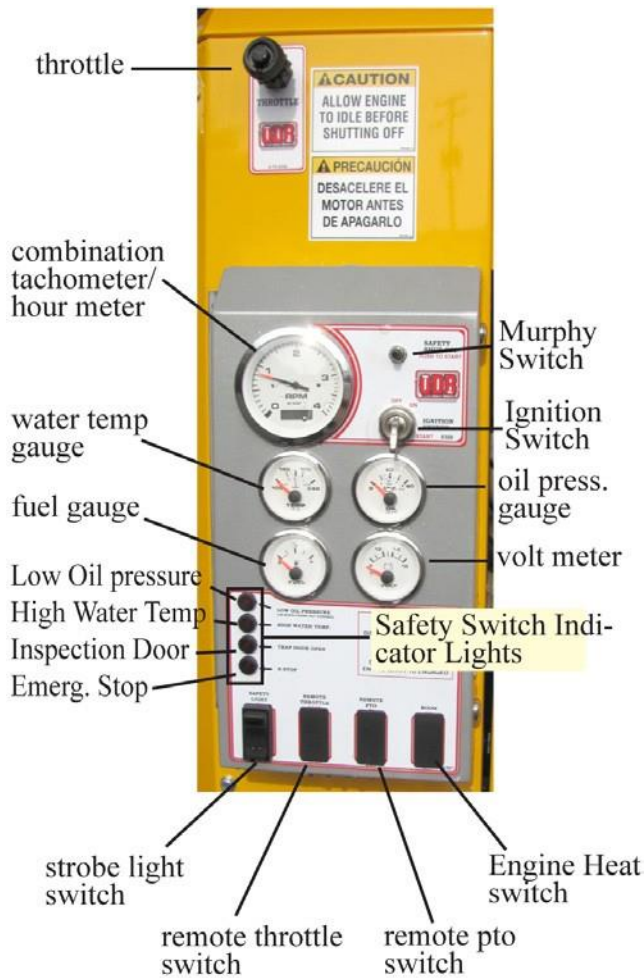

**CAUTION**

**Always make sure the PTO is disengaged before starting unit.**

## 2.1 INSTRUMENTS AND CONTROLS, cont.:

### SAFETY SWITCH INDICATOR LIGHTS

These lights work with the Murphy (safety) shut off switch. When the light is on it indicates that the shut off switch has been tripped and the light indicates which device caused the trip.

#### Low Oil Pressure Indicator Light:

When lit the engine has reached a low oil pressure reading and has tripped (thus shut off the engine) the safety shut off (Murphy) switch. This light will illuminate when the engine is first started until engine oil pressure has been established.

#### High Water Temperature Indicator Light:

Indicates the engine coolant temperature has reached 225 degrees and has tripped (thus shut off the engine) the safety shut off (Murphy) switch.

#### Inspection Door Indicator Light:

Indicates that the limit switch located on the blower housing inspection door has been tripped (thus shut off the engine).

#### Emergency Stop Switch Indicator Light:

Indicates that the emergency stop switch (on the LCT650 only) has been depressed, tripping the safety switch and shutting off the engine.

### ROCKER SWITCHES

#### Strobe Light Switch:

Turns the strobe light on or off

#### Remote Throttle Switch (optional):

Increases or decreases the engine throttle. Pressing and holding the top of the switch increases the throttle. The longer the button is pressed the higher the throttle is advanced. Pressing the bottom of the switch decreases the throttle in the same manner as increasing the throttle.

#### Remote PTO Switch (optional):

Engages or disengages the PTO. Pressing the top of the switch engages the PTO while pressing the bottom of the switch disengages the PTO.

#### Cold Start Switch (Caterpillar engines only):

Pressing the top of the switch for 5 seconds initiates the glow plug to aid in starting a cold engine.

# PRE-OPERATING SECTION

## 2.2 SAFE OPERATIONS:

### WARNING

ALL personnel using, maintaining or servicing this unit must be trained in all safety procedures outlined in this manual. Improper or careless use of this equipment CAN result in personal injury or death.

#### Operations shall be restricted to:

1. Properly trained, qualified and experienced operators and/or qualified and experienced maintenance and test personnel.
2. Trainees under the direct supervision of qualified and experience personnel.
3. Qualified and experienced maintenance and service personnel.

#### Operators who qualify to operate this equipment under the above restrictions shall also comply with the following physical requirements:

1. Have good vision and the ability to read and understand this manual as well as all safety and operational decals on the equipment.
2. Be capable of hearing, with or without a hearing aid, at a level needed to safely operate this equipment.
3. A record of mental stability with no history of epileptic seizures, dizziness, or any other disability that may result in injury to himself or others.

If any of these requirements are not satisfied at any time, the person failing to meet these requirements **MUST NOT OPERATE THIS EQUIPMENT.**

# PRE-OPERATING SECTION

## 2.2 SAFE OPERATIONS (continued):

### Additional Requirements:

1. Each operator must demonstrate competence to understand all safety decals, operator's manuals, safety codes, applicable government regulations, and all other information applicable to the safe and proper operation of the leaf vacuum.
2. Each operator must demonstrate the ability to recognize an emergency situation that may arise during vacuuming operations and the knowledge and procedures to implement corrective action.
3. Each operator must demonstrate or provide evidence of qualification and experience prior to operating the leaf vacuum.
4. Each operator must be able to recognize existing or potential problems regarding the mechanical integrity of the leaf vacuum and report any maintenance requirements to the supervisor in charge.
5. Each operator must wear the proper personal clothing and safety gear. (Refer to SAFETY PRECAUTIONS Section 5.4)
6. Operators must not be physically or mentally fatigued.
7. Operators must not be under the direct or indirect influence of alcohol and/or drugs. This includes prescription drugs that could cause drowsiness, dizziness, or any other condition that would impair their ability to operate or use this equipment in a safe manner.

# PRE-OPERATING SECTION

## 2.3 PREPARATION FOR OPERATION

### CAUTION

Before your leaf vacuum is put into operation it is very important to read and follow the procedures outlined in the engine owner's manual. (EOM).

For specific information regarding the following checks please refer to the "Maintenance" section of this manual and the engine owner's manual.

### WARNING

**DISENGAGE** the clutch and remove the negative battery cable before performing the following checks.

### WARNING

**NEVER** place any part of the body under or behind guards or any other area in which you cannot see.

### IMPORTANT CHECKS:

**NOTE:** The following checks contained in the next three sections should be performed prior to leaving the storage area.

1. Check engine fuel, coolant and oil levels. (see EOM)
2. Check engine air filter
3. Check all bolts and nuts to ensure they are tight.
4. Check all controls for free and proper operation.
5. Check main drive belt (if equipped) for proper adjustment.
6. Inspect the fan blades to ensure that they are not bent , deformed, fatigued or cracked.
7. Inspect the intake hose flange to make sure it is connected correctly to the blower housing.
8. Inspect the leaf vacuum frame and structure for any bent, broken, cracked, missing or loose parts.
9. Check all guards to ensure they are undamaged, in place and properly secured.
10. All decals must be in place and legible prior to operating the leaf vacuum. See the decal section for decal replacement.

# PRE-OPERATING SECTION

## 2.4 PRE-TRANSPORT CHECKS

### **WARNING**

Failure to properly hitch the leaf vacuum to the tow vehicle, verify the road worthiness of the leaf vacuum and the tow vehicle and verify all equipment is properly stowed, may cause serious injury or death to yourself or others.

**TOW VEHICLE MUST** have proper towing capacity for the leaf vacuum being towed. Check the tow vehicles operating manual for rated capacity.

**Do not tow the leaf vacuum unless all important checks listed below are completed.**

### IMPORTANT CHECKS:

Hitch is properly secured to tow vehicle and hose boom secured.

- a. Frame must be level or the tongue slightly lower than the rear of the leaf vacuum while towing to ensure proper weight distribution. The hitch may have to be adjusted when towing with vehicles of varying tow hitch height.

Safety chains installed correctly.

- a. Chains routed under trailer tongue in an “X” pattern between tow vehicle and trailer.
- b. Slack in chain should be adjusted to permit turning but should not be dragging on the ground.

Connect trailer wiring to the tow vehicle and ensure that all trailer lighting is operating properly.

Ensure that the safety breakaway switch is functioning properly and attached securely to the tow vehicle. Allow enough slack to ensure that vehicle turns will not activate the safety breakaway switch.

**NOTE:** Follow manufacturers procedure to ensure tow vehicles brake control box is properly adjusted.

Check the general condition of the tires, tire pressure and ensure that all lugnuts are securely fastened.

# PRE-OPERATING SECTION

## 2.4 PRE-TRANSPORT CHECKS (continued):

### IMPORTANT CHECKS (continued):

6. Visual examination of the leaf vacuum frame, suspension and structure to determine if all components are correctly positioned and secured for travel.
7. Check the intake hose boom to verify that it is securely fastened to the leaf vacuum and can not swing free.
8. Verify there are no loose tools or materials on the trailer, inside the intake and exhaust hoses, or inside the engine sheet metal.
9. Check all cones, wheel-chocks, signs or other support tools and materials to ensure proper stowage.
10. Verify the driver of the tow vehicle is qualified to tow the type and weight of the unit.

# PRE-OPERATING SECTION

## 2.5 PERSONAL PROTECTIVE EQUIPMENT AND CLOTHING

### IMPORTANT CHECKS:

Anyone operating ODB's leaf vacuums **MUST** wear appropriate protective equipment and clothing to protect them from injury during operations.

### **WARNING**

**Always** wear proper safety equipment as outlined below, not wearing such equipment **CAN** result in serious personal injury or possible death.

### PROTECTIVE EQUIPMENT:

1. **Head Protection:** Hard hats without under-chin strapping.
2. **Eye Protection:** Wraparound goggle type eye protection held in place with an elastic band around the head or a hard hat mounted face shield, which provides full protection of the face. Eye protection must meet ANSI Z87.1 standards.
3. **Hearing Protection:** plug type or "muff type" ear protection should be worn at all times while operating the unit.
4. **Breathing Protection:** Paper filter type dust masks should be worn to protect from dirt and dust particles during the vacuuming process.
5. **Reflective Vests:** Highly visible vests should be worn so motorists can see the operator in all weather and lighting conditions.
6. **Work Gloves:** Gloves should be worn to protect the hands and wrists from debris.
7. **Steel Toed Boots:** should be worn to protect the feet.

### **DANGER**

Work clothes **MUST** be close fitting, but not restrictive of movement, without any loose parts that could be entangled in any parts of the leaf vacuum. This includes items such as jewelry, chains and backpacks.



# PRE-OPERATING SECTION

## 2.6 WORK SITE PREPARATION

### WARNING

**Never place any part of the body under or behind guards or any other visually obscured area.**

**Making sure the leaves are clear of possible dangerous material is critical to safe vacuuming. Vacuuming up metal, glass, rocks or other dangerous material CAN cause serious damage to the equipment or personal injury.**

**The following guidelines must be followed to insure safety.**

1. An inspection of the leaves to be vacuumed must be done prior to the vacuuming process. We realize that it is impossible to completely inspect every inch of leaves being vacuumed, but it is imperative that all leaves be inspected for obvious dangerous material before vacuuming.
2. The operator should never be in the line of traffic, the operator should work on the shoulder whenever possible.
3. The operators should place cones or other barriers to provide adequate warnings to vehicles and pedestrians that vacuuming is in progress.
4. Strobe lights on the leaf vacuum and on the tow vehicle should be on at all times for high visibility.
5. Confirm that all operators are wearing proper clothes and personal protective equipment.
6. Restrict all personnel, except the operator from the area near the leaf vacuum. **DO NOT** allow pedestrians, children or animals near the work area.
7. Make sure that the exhaust hose fits properly into the box container so that all debris is blown into the box container.

# OPERATING SECTION

## **WARNING**

Read and understand this entire manual before operating, maintaining or repairing the leaf vacuum.

## 3.0 OPERATING SECTION

### 3.0 OPERATING SECTION

### 3.0 OPERATING SECTION

3.1 Starting Engine .....	27
3.1 Starting Engine, continued;.....	28
3.2 Engaging the Impeller.....	29
3.2 Engaging the Impeller, continued;.....	30
3.3 Dumping the Body.....	31
3.3 Dumping the body, continued;.....	32
3.3 Dumping the Body, continued; .....	33
3.4 Vacuuming Leaves.....	34

# OPERATING SECTION

figure 3a

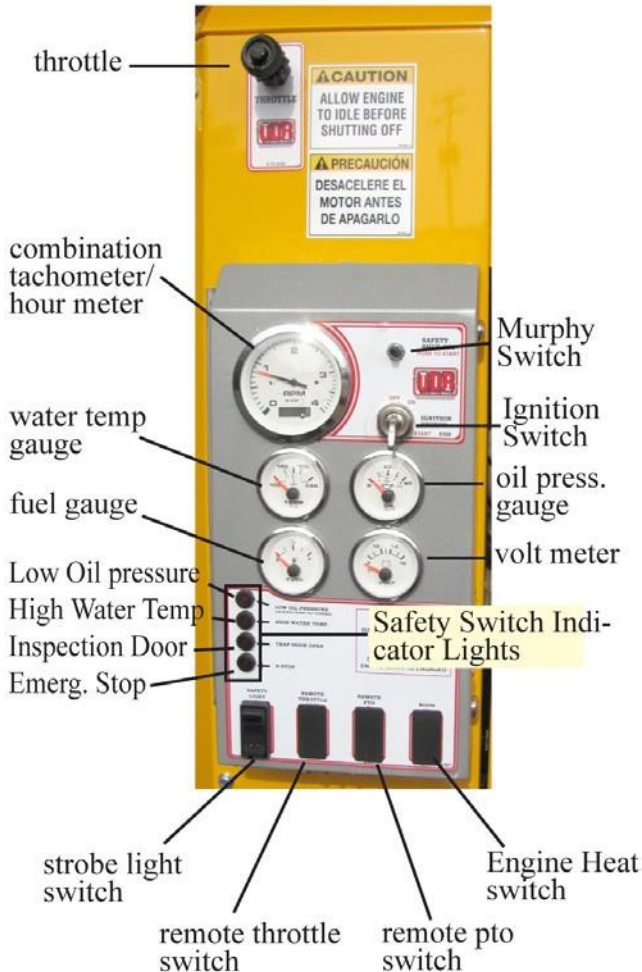

## 3.1 Starting Engine

### CAUTION

Always make sure the PTO is disengaged before starting unit. (See figure 3b)

### WARNING

Thoroughly read and understand the safety and pre-operating sections of this manual before starting the engine.

### CAUTION

**DO NOT** start the engine in an enclosed building. Proper ventilation is required before starting the engine.

Review the Engine Operating Manual supplied with your leaf vacuum for specific start-up, maintenance and operating instructions. It is especially important to review break-in service procedures for brand new units.

### Starting Procedure (refer to figures 3a and 3b):

1. Perform all the pre-starting, pre-operating checks outlined in the EOM and in this manual.
2. Make sure the PTO is disengaged.
3. Turn the throttle control (fig. 3a) counter-clockwise 2 revolutions.
4. Depress and hold the Murphy switch while starting.

# OPERATING SECTION

figure 3a

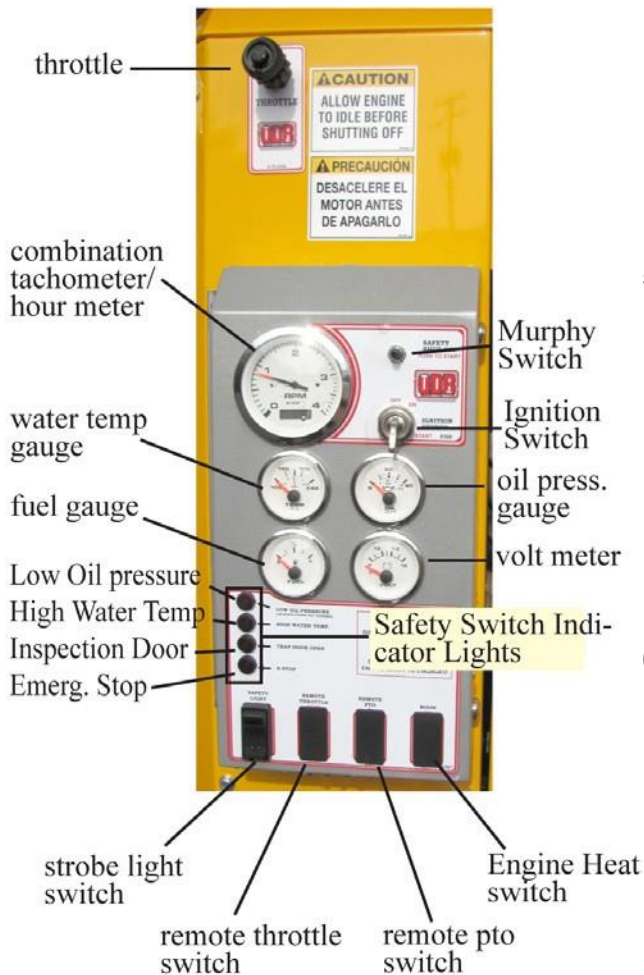

## 3.1 Starting Engine, continued;

**IMPORTANT:** Do not operate the starter for more than 30 seconds at a time. To do so may overheat the starter. If the engine does not start the first time, wait at least 2 minutes before trying again. If the engine fails to start after 4 attempts, see the trouble shooting section of the EOM and this manual.

5. Pull the ignition switch all the way out, when the engine starts release the ignition switch. It should spring back to the first position.

**IMPORTANT:** If the ignition switch is released before the engine starts, wait until the starter and the engine stop turning before trying again. This will prevent possible damage to the starter and/or flywheel.

6. After the engine starts, continue to hold the Murphy Switch in until the oil pressure gauge reads at least 15 psi. The Murphy shut off switch will not allow the engine to operate below this level. If the gauge does not rise above 15 psi within 5 seconds, stop the engine and determine the cause. Normal operating oil pressure is 50 psi with oil at normal operating temperature.
7. Check all gauges for normal engine operation. If operation is not normal, stop the engine and determine the cause.

**IMPORTANT:** To assure proper lubrication, operate the engine at or below 1200 rpm with no load for 1 -2 minutes. Extend this period 2 - 4 minutes when operating at temperatures below freezing.

8. Watch the coolant temperature gauge. Do not place engine under load until it is properly warmed up. The normal engine coolant temperature range is 180 - 202 degrees F.

# OPERATING SECTION

figure 3a



figure 3.2a

Impeller shown disengaged



Handle is horizontal when disengaged

## 3.2 Engaging the Impeller

### CAUTION

Make sure the intake hose is connected properly and that people and objects are clear of the hose.

### WARNING

Thoroughly read and understand the safety and pre-operating sections of this manual and the engine owner's manual before starting the engine.

### CAUTION

**DO NOT** start the engine in an enclosed building. Proper ventilation is required before starting the engine.

Review the Engine Operating Manual supplied with your leaf vacuum for specific start-up, maintenance and operating instructions. It is especially important to review break-in service procedures for brand new units.

### Impeller Engagement Procedure (refer to figure 3.2a):

1. Perform all the pre-starting, pre-operating checks outlined in the EOM and in this manual, including checking the engine oil and coolant level.
2. Check that the intake hose is connected properly and that people and objects are clear of the hose before starting the engine.
3. Start the engine as detailed in section 3.1
4. Run at idle for several minutes before engaging the impeller

# OPERATING SECTION

## 3.2 Engaging the Impeller, continued;

Impeller shown engaged



Handle is vertical when engaged

### ⚠ CAUTION

Be aware of the intake nozzle before impeller engagement. Secure is safely.

### ⚠ CAUTION

Engage the belt SLOWLY so the engine will not stall.

### ⚠ CAUTION

Allow the engine to warm up sufficiently before collecting leaves. Collecting leaves with a cold engine WILL cause engine damage.

### ⚠ CAUTION

Reduce engine speed to idle for one minute before shutting engine off. Engine damage can occur from run-on or after-burning if engine is stopped suddenly from high speed operation.

5. Raise the engine rpm to approximately 1,700 RPM.
  6. **SLOWLY** raise the handle toward the engine to engage the belt and impeller. This must be done **SLOWLY** so the engine will not stall.
- IMPORTANT:** Make sure the intake hose is secured and is not going to vacuum something unintentional during engagement.
6. Check for any vibration or irregular noise before vacuuming leaves. If there is any vibration or irregular noise, shut down the unit immediately and investigate.

**IMPORTANT:** To assure proper lubrication, operate the engine at idle with no load for 1 -2 minutes. Extend this period 2 - 4 minutes when operating at temperatures below freezing.

## DISENGAGING THE IMPELLER

7. Lower the engine RPM to idle and **SLOWLY** pull the handle to a horizontal position.
8. Run the engine for at least one minute before shutting down the engine.

# OPERATING SECTION

## 3.3 Dumping the Body

### **⚠ DANGER**

Make sure all people and animals are completely clear of the unit during the dumping process.

### **⚠ WARNING**

Thoroughly read and understand the safety and pre-operating sections of this manual before starting the engine.

### **⚠ DANGER**

Always operate the dump body controls from the front of the unit, standing beside the tongue.

### **⚠ WARNING**

Make sure the unit is properly attached to the tow vehicle and the surface is level and solid before raising the body .

figure 3.3a

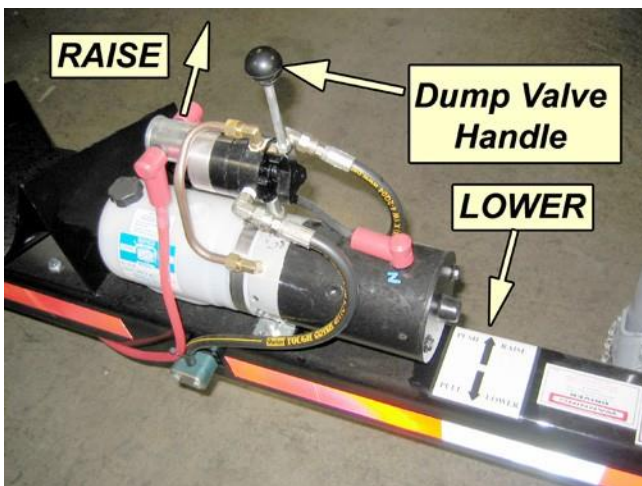

### **⚠ WARNING**

Watch for any overhead obstacles such as power lines and tree limbs before dumping.

Review the Engine Operating Manual supplied with your leaf vacuum for specific start-up, maintenance and operating instructions. It is especially important to review break-in service procedures for brand new units.

#### **Dumping the body (refer to figures 3.3a and 3.3b):**

1. Perform all the pre-starting, pre-operating checks outlined in the EOM and in this manual.
2. Do a thorough inspection of the entire area around and above the unit, looking for any object that could get in the way of the body dumping.
3. Make sure the surface is level and the ground is solid before dumping.
4. Open the rear doors and secure to the side of the box container.

figure 3.3b



# OPERATING SECTION

figure 3.3a

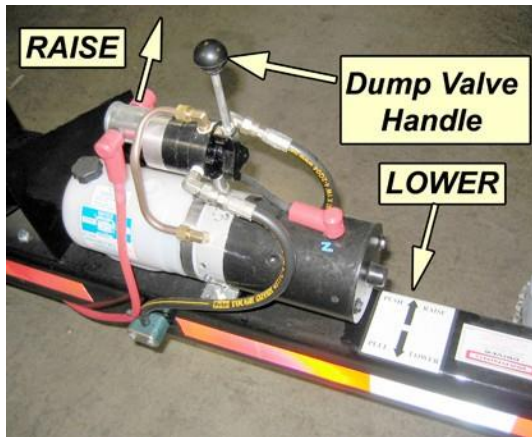

## 3.3 Dumping the body, continued;

5. Grasp the hand valve handle (fig. 3.3a) push the handle to the right(toward the radiator) to raise the body.
6. Raise the body only as high as it is needed to dump the load.
7. Shut off all power, raise the body prop(s) (fig. 3.3b) to a free standing position. Lower the body slowly until the the long beam bracket contacts the prop arm saddle (fig. 3.3c). **DO NOT POWER HOIST DOWN.**

### Lowering the body:

1. Before lowering the body, walk completely around the unit and thoroughly inspect the area between the body and the unit's frame. Look for any object, person or animal that could potentially get between the dump body and the frame. **DO NOT** go under the body while inspecting.
2. Slowly raise the body just enough to clear the body prop saddle, lower the body prop to the storage position (fig 3.3c) and slowly lower the body.
3. The dump body may stop approximately 12" from the bottom due to the safety check valve. If it does, slowly raise the body a few inches and **SLOWLY** lower the body down. The body needs to be lowered extremely slow the last 12 inches or the check valve will stop the body.
4. Once the body is completely down, close the rear doors and prepare the unit for travel as detailed in this manual.

figure 3.3b

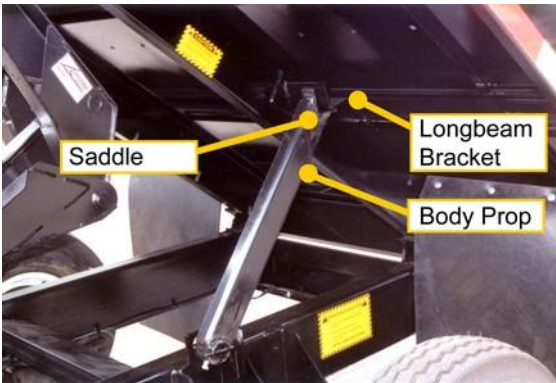
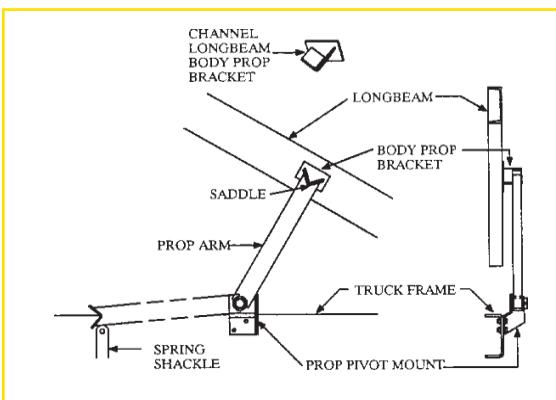

figure 3.3c





# OPERATING SECTION

## 3.3 Dumping the Body, continued;

### **⚠ DANGER**

Make sure all people and animals are completely clear of the unit during the dumping process.

### **⚠ WARNING**

Thoroughly read and understand the safety and pre-operating sections of this manual before starting the engine.

### **⚠ DANGER**

Always operate the dump body controls from the front of the unit, standing beside the tongue.

### **⚠ WARNING**

Make sure the unit is properly attached to the tow vehicle and the surface is level and solid before raising the body .

### **⚠ WARNING**

Watch for any overhead obstacles such as power lines and tree limbs before dumping.

figure 3.3a

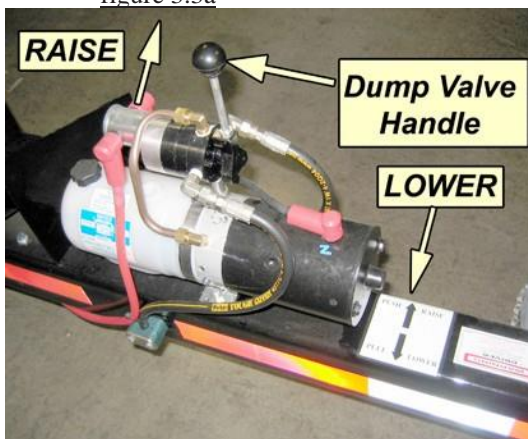

### Please Note:

The hoist hydraulic pump (figure 3.3a) is powered by the battery and is only capable of dumping the hoist 3 - 4 times before the battery needs to be recharged.

At the end of EVERY day the battery needs to be recharged by plugging the battery charger (figure 3.3d) into an electrical outlet

Do not try to operate the hoist with a discharged battery as it may damage the hydraulic pump.

figure 3.3d

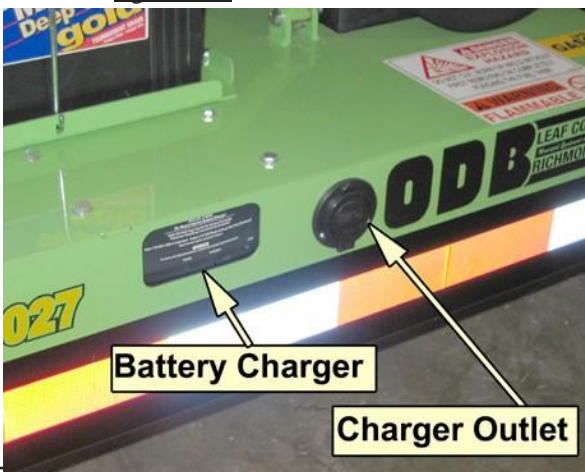

# OPERATING SECTION

## 3.4 Vacuuming Leaves

### WARNING

Thoroughly read and understand the safety, pre-operating and operating sections of this manual before vacuuming. Wear the proper safety equipment as outlined in this manual.

### WARNING

Make sure the exhaust hose is connected to the box container properly before vacuuming leaves. Visually inspect the leaves before vacuuming for any material that could be harmful to the leaf vacuum or people. This includes bottles, wood, steel, glass, stone or other hard or breakable objects.

### Vacuuming Leaves:

1. Start the engine using the procedures stated earlier in this manual.
2. Engage the impeller as previously described.
3. Set the engine throttle to around 1,400 rpm.

**NOTE:** Always vacuum leaves using the lowest rpm as possible. This saves fuel and decreases the amount of dust escaping the box container.

4. Lower the intake hose to a few inches above the leaf pile. Hold the intake nozzle at a 45 degree angle to allow proper air flow. This should allow the leaves to be vacuumed. **DO NOT** bury the intake nozzle into the leaf pile, this will cut off the air flow and will make vacuuming much more difficult and increase the chance of clogging.
5. If the leaves are not vacuuming, increase the rpm to 1,600 and try vacuuming at this setting.

**NOTE:** Wet leaves will need higher rpm's to vacuum whereas dry leaves will only need minimal rpm's.

6. Continue moving the nozzle in a sweeping motion above the leaves while vacuuming.

# Maintenance Section

## WARNING

Read and understand this entire manual before operating, maintaining or repairing the leaf vacuum.

## 4.0 MAINTENANCE SECTION

### 4.0 MAINTENANCE SECTION

4.1 MAINTENANCE OVERVIEW .....	36
4.2 MAINTENANCE AND LUBRICATION CHART .....	37
4.3 LUBRICATION: .....	38
4.3 LUBRICATION, continued; .....	39
4.3 LUBRICATION, continued; .....	40
4.3 LUBRICATION, continued; .....	41
4.4 PREVENTATIVE MAINTENANCE .....	42
4.4 PREVENTATIVE MAINTENANCE, continued;.....	43
4.4 PREVENTATIVE MAINTENANCE, continued;.....	44
4.4 PREVENTATIVE MAINTENANCE, continued;.....	45
4.5 TORQUE VALUES .....	46

## 4.0 MAINTENANCE SECTION

# Maintenance Section

## 4.1 MAINTENANCE OVERVIEW:

### CAUTION

Only properly trained personnel should perform maintenance or repair on this equipment. Consult ODB before performing any maintenance procedures that is not specifically covered in this manual. Improper maintenance or repair may void any and all warranties on this equipment.

### WARNING

Improper maintenance or repair CAN result in equipment damage and/or personal injuries.

### DANGER

**BEFORE CONTINUING**, please read and understand the Safety, Pre-operating and Operating sections of this manual before doing any procedures in this section.

A properly maintained leaf vacuum will dramatically extend the life of the unit and will create a safer work place as well. For the general safety and welfare of all personnel it is important to create a scheduled maintenance program that covers all the elements in this manual as well as the engine, PTO and axle owner's manuals provided with this unit.

Use the chart on the following page as a guide for your scheduled maintenance program. If there are any questions concerning any of these procedures please call your Xtreme Vac dealer.

# Maintenance Section

## 4.2 MAINTENANCE AND LUBRICATION CHART

This chart is only a reference, always consult the Owners Manual of the Engine, PTO, etc for actual recommendations

(Use Hour Meter as a Guide)

MAINTENANCE	INTERVAL					
	Daily	First 8 Hours	Every 25 Hours	Every 50 Hours	Every 100 Hours	Every 200 Hours
Check and add engine oil, coolant and fuel*	●					
Check for loose nuts or bolts	●					
Check for fuel, oil and coolant leakage	●					
Check or clean air intake screen*	●					
Lubricate Impeller Shaft Flange Bearings	●					
Check Lug Nuts and Tire Pressure / Condition	●					
Check Trailer Safety Chains and Hitch	●					
Check Tow Bar for Damage or Wear	●					
Clean air cleaner foam element*	●					
Clean air cleaner paper element*	●					
Plug in battery charger (every night)	●					
Change engine oil*		●			●	
Clean and Check Battery and Connections			●			
Check Power Band Tension / Condition			●			
Check Electric Brakes			●			
Check Impeller for Damage, Cracks or Wear			●			
Lubricate Throttle and Choke Cables				●		
Check Blower Housing Interior for Cracks or Wear				●		
Inspect Intake Hose for Damage				●		
Clean and regap spark plug*					●	
Replace oil filter*					●	
Replace air cleaner paper element*					●	
Inspect radiator and hoses*(k)					●	
Check fan belt conditions and tension*(k)					●	
Inspect all Duct Work for Cracks, Holes or Wear					●	
Grease / Inspect Wheel Bearings for Corrosion						●
Change coolant*(k)						●

Check Fuel Tank for Corrosion / Cracks

\* = see the engine owner's manual for complete details

k = have an authorized Kawasaki engine dealer perform those services

# Maintenance Section

## 4.3 LUBRICATION:

### ⚠ CAUTION

Remove the negative battery terminal before attempting any lubrication procedures.

### ⚠ WARNING

Thoroughly read and understand the safety and pre-operating sections of this manual before performing any lubrication procedures.

Figure 4.3A



Grease Points

**NOTE:** DO NOT mix different types of grease. The old grease MUST BE purged before a different type of grease is used. Mixing grease WILL cause premature failure to the bearings.

The following are general lubrication procedures for our standard units. Any special or custom built units may have other lubrication procedures not directly mentioned in this manual. Please consult ODB before any lubricating procedures not specifically mentioned in this manual.

Proper lubrication of your unit correlates directly to how long your unit will last. A properly maintained unit will last much longer than a unit that is not maintained properly.

**NOTE:** Always lubricate bearings at the end of each work day. This will displace any moisture in the bearings. Also lubricate thoroughly before extended shutdown or storage.

### Lubrication Points:

1. **Drive Bearings (if equipped) (figure 4.3a):**  
These bearings are critical components of the belt-driven units. These bearings should be greased every 10 hours with approximately two strokes from the average hand pump grease gun. The type of grease used in these bearings are also critical to the performance of the bearings. A multi-purpose, heavy-load, high-temperature, moisture resistant #2 grease is required for the drive bearings. ODB recommends LubeMaster Premalube 4234 grease. Other premium quality grease that matches the above requirements may be used but after years of testing ODB recommends the Premalube grease.

# Maintenance Section

## 4.3 LUBRICATION, continued;

### Lubrication Points, continued:

2. **Trailer Wheel Bearings (figure 4.3b):** Most of ODB's units are equipped with "EZ-Lube" grease fittings. This allows the operator to grease the bearings without removing the hubs. The "EZ-Lube" feature consists of axle spindles that have been specially drilled and fitted with a grease zerk in their ends (fig. 4.3c). When grease is pumped into the zerk, it is channelled to the inner bearing and then flows back to the outer bearing and eventually back out the grease cap hole. The trailer wheel bearings should be checked and greased after the first 30 days of service then at the beginning of every season.

Figure 4.3b



Grease fitting is behind rubber plug

### Grease specifications:

Thickener Point.....	Lithium Complex
Dropping Point.....	230 degr. C minimum
Consistency.....	NLGI No.2
Additives.....	EP, Corrosion & Oxidation Inhibitors
Base Oil.....	Solvent refined Petroleum Oil
Base Oil Viscosity.....	@40 deg. C 150cSt Min.
Viscosity Index.....	80 Minimum
Pour Point.....	-10 deg. Minimum

Figure 4.3c

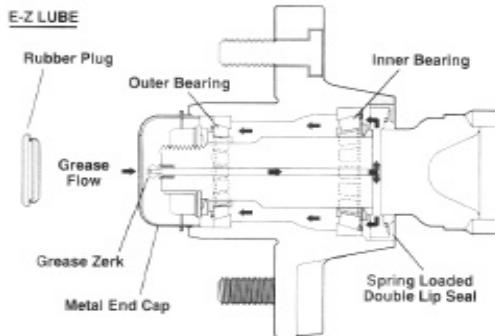

### Approved Sources:

Mobil Oil.....	Mobilgrease HP
Exxon/Standard.....	Ronex MP
Kendall Refining.....	Kendall L-427
Ashland Oil Co.....	Valvoline Val-plex EP Grease.
Penzoil.....	Premium Wheel Bearing Grease 707L

For any questions concerning wheel lubrication please consult the axle owner's manual supplied with your leaf collector or contact ODB.

# Maintenance Section

Figure 4.3d

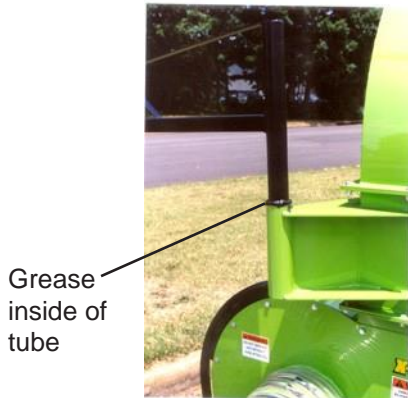

Figure 4.3e



## 4.3 LUBRICATION, continued;

### Lubrication Points, continued:

3. **Boom Socket (figure 4.3d):** The socket should be greased once a week to keep the boom mast moving smoothly. Grease the boom socket once every week with a multi-purpose moisture resistant #2 grease.
4. **Hinge and Friction Points:** Leaf vacuum operation and longevity can be improved by keeping hinges and friction points lubricated. ODB recommends that lubrication be performed weekly. Use SAE30 weight oil on hinges and a premium grade, high temperature lithium based EP#2 grease on friction points.
5. **Boom Extension (figure 4.3e):** Grease the extension tube once every week with a multi-purpose lubricant.

### **⚠ WARNING**

Never go under the dump body unless the body is empty and the body prop(s) is in the proper position.

### **⚠ WARNING**

The body prop is designed and intended to support an **EMPTY** truck body in the raised position. Unload the body before using the body prop(s).



# Maintenance Section

## 4.3 LUBRICATION, continued;

### Lubrication Points, continued:

Figure 4.3f

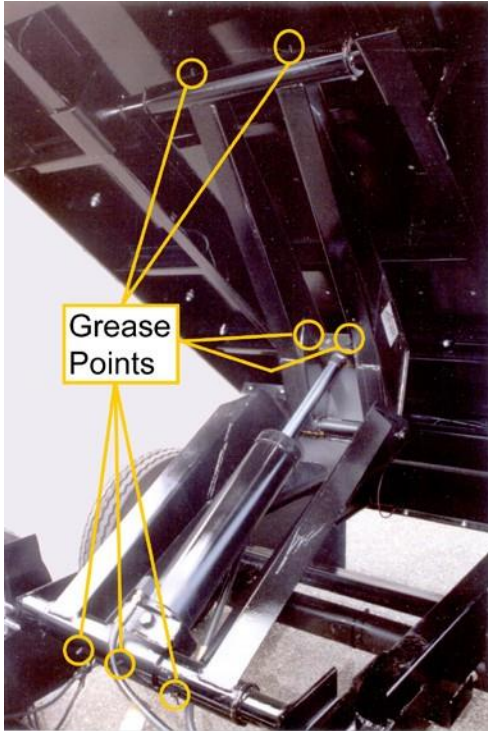

### **⚠ WARNING**

Never go under the dump body unless the body is empty and the body prop(s) is in the proper position.

6. **Hydraulic Hoist Fittings (figure 4.3f):** Raise and support the dump body as detailed in section 3.2. Lubricate the fittings at least every 200 hours of operation with a #2 high grade grease. There are tremendous forces on the bearing surfaces within the hoist frame. It pays to be generous with the grease gun, to insure proper operation and long life.

7.

### **Hoist Hinge and Body Prop(s) Fittings (figure 4.3g):**

Each hinge pivot has a grease fitting that needs lubricating every 200 hours. The body prop(s) has a fitting at the pivot area as shown in figure 4.3g.

Figure 4.3g

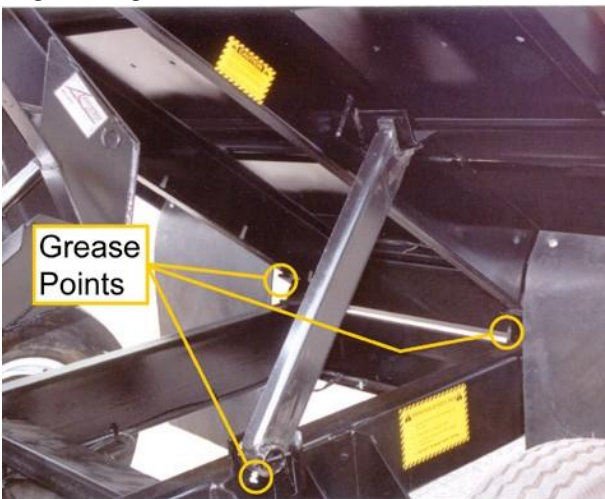

### **⚠ WARNING**

The body prop is designed and intended to support an **EMPTY** truck body in the raised position. Unload the body before using the body prop(s).

# Maintenance Section

## 4.4 PREVENTATIVE MAINTENANCE

### ⚠ CAUTION

Remove the lead spark plug wires before attempting any maintenance procedures.

### ⚠ WARNING

Thoroughly read and understand the safety and pre-operating sections of this manual before performing any maintenance procedures.

The following are general preventative maintenance procedures for our standard units. Any special or custom built units may have other preventative maintenance procedures not directly mentioned in this manual. Please consult ODB before doing any preventative maintenance procedures not specifically mentioned in this manual.

Proper preventative maintenance of your unit, just like lubrication, correlates directly to how long your unit will last. A properly maintained unit will last much longer than a unit that is not maintained properly.

### Preventative Maintenance:

1. **Engine Oil:** Change the oil and oil filter according to schedules provided in your engine's owner's manual (EOM). The engine oil level should be checked every day. The level should be checked after the engine has been stopped for a period of time. This will allow the oil to drain back into the oil pan, allowing a better indication of the true oil level. If the level is low, see the engine's owner's manual for the correct type of oil.
2. **Engine Coolant:** Check the coolant level before starting the unit each day. The coolant level should not be less than one inch below the top of the radiator.

### ⚠ CAUTION

**NEVER** check the engine coolant when the engine is hot. Allow the engine to cool at least one hour before checking the coolant. Check the engine owner's manual for instructions. **ALWAYS** wear eye and hand protection when working with the radiator.

# Maintenance Section

## 4.4 PREVENTATIVE MAINTENANCE, continued;

### Preventative Maintenance, continued:

3. **Engine Radiator:** The engine radiator on a leaf vacuum becomes clogged with dust and debris frequently because of the nature of the job. If the radiator is not cleaned properly it WILL cause improper cooling and WILL eventually cause serious damage to your engine. The debris accumulating on the radiator can be lessened by lowering the RPM on the engine to a level just enough to vacuum the leaves. The higher the RPM the more dust that is put into the air. Also, it may be necessary to put mesh or tarps on the top of the leaf box container to reduce the debris and dust. If this is done, make sure there is enough air ventilation on the box so the box is not blown apart. Proper belt condition and coolant mix-ratio, as well as coolant conditioners, are all critical to proper engine cooling. See the engine's owner's manual for specifics on coolant mixture ratios and conditioners. The radiator should be inspected and cleaned with compressed air everyday at the very least.

### DANGER

**NEVER attempt to clean or inspect the radiator with the engine running or while the engine is HOT. Allow the engine to cool at least one hour before maintaining the radiator. Check the engine owner's manual for instructions. ALWAYS wear eye and hand protection when working with the radiator.**

4. **Engine Air Cleaner:** Due to the large amounts of dust generated in collection leaves, it is critical to your engine's life that the pre-cleaner and air filter be maintained properly. The pre-cleaner (if equipped) should be cleaned at least daily of any debris that has accumulated. If conditions warrant it should be cleaned more. The air filter should be checked daily and should be replaced at the first sign of it being dirty. See the engine's owner's manual for details. It is a good idea to clean out the air filter housing once a week to clean any dust debris that may have accumulated.
5. **Tires and Wheels:** Tires and wheel lug nuts should be checked on a daily basis. Tires should be checked for excessive wear and proper air pressure. Check the side wall of the tire for proper inflation pressure. Torque all 1/2" diameter lug nuts from 90 to 120 foot pounds. Torque all 5/8" diameter lug nuts from 175 to 225 foot pounds. Consult the axle manufacturer's owner's manual for more detailed information.

# Maintenance Section

## 4.4 PREVENTATIVE MAINTENANCE, continued;

### Preventative Maintenance, continued:

6. **Trailer Brakes (if equipped):** Most of the newer ODB leaf vacuums have electric brakes on the axle(s). It is critical that these brakes work properly. The trailer's brakes should be checked daily, before leaving the equipment yard, for proper operation. The trailer brakes are designed to work in synchronization with your tow vehicles brakes. Never use your tow vehicle or trailer brakes alone to stop the combined load. The synchronization between the tow vehicle and the leaf vacuum is accomplished through the brake controller and needs to be set correctly. Please read the brake controllers manual and the axle owner's manual for these procedures.

### **WARNING**

**DO NOT tow the leaf vacuum with damaged or non-operating brakes. Check the brakes daily for proper operation.**

The brakes should be adjusted after the first 200 miles of operation when the brake shoes and drums have "seated" and at 3,000 mile intervals, or as use and performance requires. The adjustment procedures are beyond the scope of this manual, please see the axle owners/service manual for specific instructions.

The trailer brakes should be inspected and serviced at yearly intervals or more often as use and performance requires. Magnets and shoes must be changed when they become worn or scored thereby preventing adequate vehicle braking. Again, see the axle owner's/service manual for specific procedures.

7. **FUEL TANK:** Fill the fuel tank at the beginning of the work shift leaving a gap of at the top of the tank for expansion of fuel. A full fuel tank will reduce the possibility of condensation forming in the tank and moisture entering the fuel lines. Check the fuel lines daily for cracks, holes or tightness.

# Maintenance Section

## 4.4 PREVENTATIVE MAINTENANCE, continued;

### Preventative Maintenance, continued:

#### CAUTION

**ALWAYS** wear eye and hand protection when working with the battery.

8. **BATTERY:** ODB's units are supplied with "maintenance free" batteries so there is no need to check fluid levels but the battery terminals should be checked daily for corrosion. Remove any corrosion with a wire brush and coat the terminals with light grease or petroleum jelly to reduce the possibility of corrosion. Also check the battery cable for wear all cable connections and battery tie downs to be certain that they are not loose.
9. **DRIVE BELT (if equipped):** The main drive belt should be checked daily for cracks and for proper tension. If the belt shows any sign of

#### CAUTION



**Remove the lead spark plug wires before removing the belt guard.**

cracking it should be replaced immediately. The proper tension of the belt should be approximately 1/2" deflection when applying a 8 pound pull.

10. **FASTENERS:** Fasteners should be checked weekly for the first 30 days and monthly thereafter. They must be in place at all times and properly torqued. For general torque values see the torque chart at the end of this section.

# Maintenance Section

## 4.5 TORQUE VALUES

RECOMMENDED TORQUE IN FOOT POUNDS		
TYPE	HEX HEAD CAP SCREWS	
SAE GRADE	5	8
HEAD MARK		
SIZE		
1/4"	9	9
5/16"	18	18
3/8"	33	33
7/16"	52	52
1/2"	80	80
9/16"	115	115
5/8"	160	160
3/4"	280	280
7/8"	450	450
1"	675	675

DO NOT use these values if a different torque value or tightening procedure is given for a specific application. Torque values listed are for general use only. Check tightness of fasteners periodically.

Make sure fastener threads are clean and that you properly start thread engagement. This will prevent them from failing when tightening.

# Service Section

## **WARNING**

Read and understand this entire manual before operating, maintaining or repairing the leaf vacuum.

## 5.0 SERVICE SECTION

### 5.0 SERVICE SECTION

5.1 Belt Adjustment / Removal.....	48
5.1 Belt Drive Adjustment, continued; .....	49
5.2 Impeller Removal / Installation .....	50
5.2 Impeller Removal / Installation .....	51
5.3 Impeller Bearings Removal / Installation .....	52
5.4 Main Circuit Board Plug Diagram.....	53
5.5 Main Circuit Board Plug Diagram.....	54
5.6 Flow Control Valve Adjustment Instructions.....	55
5.7 Trailer Plug Wiring Diagram.....	56
5.8 Hoist Hydraulic Schematic .....	57

### 5.0 SERVICE SECTION

# Service Section

## 5.1 Belt Adjustment / Removal

### ⚠ CAUTION

Make sure the engine is OFF and the lead spark plug wires have been removed before attempting any service procedures.

### ⚠ WARNING

Thoroughly read and understand the safety and pre-operating sections of this manual before proceeding.

### ⚠ CAUTION

The engine may be HOT, use caution when working around the engine and muffler area.

### ⚠ WARNING

Before removing any safety guards make sure the engine has been disabled by removing the lead spark plug wires.

Belt adjustment / Removal is made easy by the using the engine adjustment brackets and bolts. Be careful when working around the engine and muffler area, as it may be hot. On a new unit, the belt should be adjusted after the first 30 hours of use and every 100 hours thereafter.

figure 5.1A

### Belt Adjustment / Removal Procedure :

1. Disengage the impeller by pulling the handle to a horizontal position. (see figure 5.1A)
2. Remove the belt guard cover by removing the bolts around the cover plate (Item A on FIG. 5.1B).
3. Loosen the engine base bolts (Item B on FIG. 5.1B), there are 2 in the front and 2 in the rear.



figure 5.1B

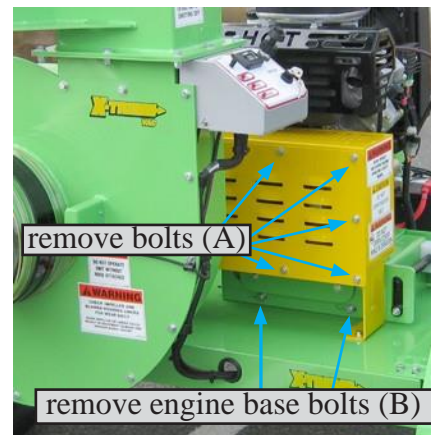
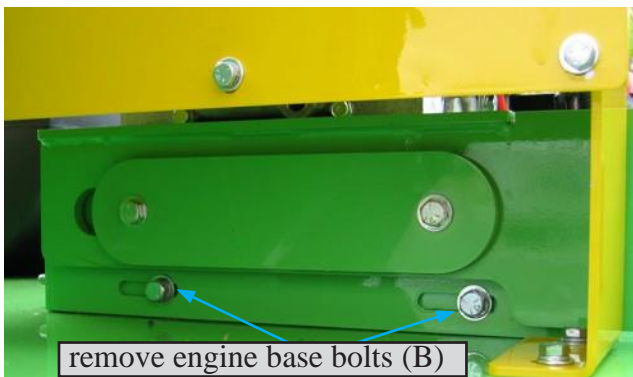



# Service Section

## 5.1 Belt Drive Adjustment, continued;

figure 5.1C

### **Belt Adjustment / Installation Procedure :**

1. Then drive the adjuster bolts (Item C on FIG. 5.1C and FIG. 5.1D) counter-clockwise to move the engine toward the impeller shaft. This will loosen the belt.
2. If you are removing the belts, the belt keepers must be removed also. There are 4 belt keepers, 2 on each pulley.

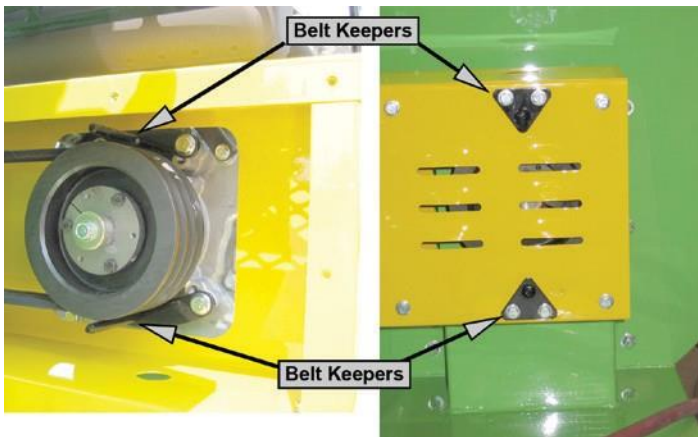

figure 5.1D

3. To tighten or install the belt, make sure the two pulleys are lined up. Use a straight edge to make sure (FIG 5.1E). If the pulleys are not lined up loosen one of the pulleys and move the pulley in or out until the two pulleys line up.
4. Tighten the belt by turning the adjuster bolt clockwise until the belt is tight. The correct tension is when the belt deflects 1/2" using an 8 pound pull. DO NOT OVERTIGHTEN.
5. Re-install the belt guard cover exactly as you removed it.

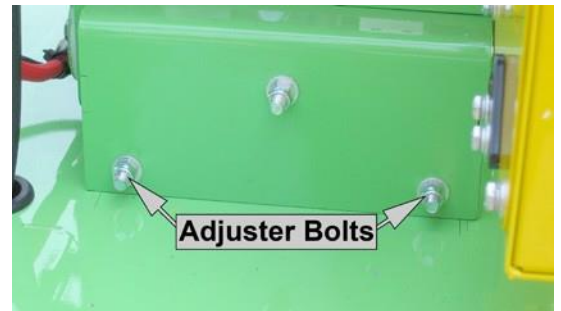

figure 5.1E



# Service Section

## 5.2 Impeller Removal / Installation

### ⚠ CAUTION

Make sure the engine is OFF and the lead spark plug wires have been removed before attempting any service procedures.

### ⚠ WARNING

Thoroughly read and understand the safety and pre-operating sections of this manual before proceeding.

### ⚠ CAUTION

The engine may be HOT, use caution when working around the engine and muffler area.

### ⚠ WARNING

Before removing any safety guards make sure the engine has been disabled by removing the lead spark plug wires.

### Impeller Removal :

1. Disconnect the negative cable from the battery attempting to open the blower housing face.
2. Remove the blower housing face by removing the bolts that hold the face on to the blower housing back (FIG 5.2A).
3. Once the blower housing face has been removed, look at the condition of the inside of the housing (FIG 5.2B). Check for any holes or wear. If any damage is found, REPLACE the housing immediately. Do not try to repair.
4. Remove the center bolt in the impeller by turning it counter-clockwise (Item A FIG 5.2C) Remove the washer and the the impeller should come out. In some instances it may be necessary to connect a gear puller to the threaded holes in the impeller hub (Item B FIG 5.2C) in order to remove the impeller.

figure 5.2A



figure 5.2B



figure 5.2C

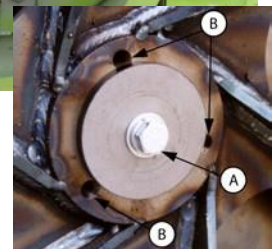

# Service Section

## 5.2 Impeller Removal / Installation

### ⚠ CAUTION

Make sure the engine is OFF and the lead spark plug wires have been removed before attempting any service procedures.

### ⚠ WARNING

Thoroughly read and understand the safety and pre-operating sections of this manual before proceeding.

### ⚠ CAUTION

The engine may be HOT, use caution when working around the engine and muffler area.

### ⚠ WARNING

Before removing any safety guards make sure the engine has been disabled by removing the lead spark plug wires.

### Impeller Installation :

1. To install put the impeller hub on the shaft. Overhang the hub over the shaft by about 1/8". Then apply the washer and the bolt (Figure 5.2C). This will "squeeze" the hub onto the shaft to create a tight fit.
2. Torque the impeller bolt to 90 lbs/ft.
3. Install the blower housing face as it was taken off. (Figure 5.2A)

figure 5.2A



figure 5.2B

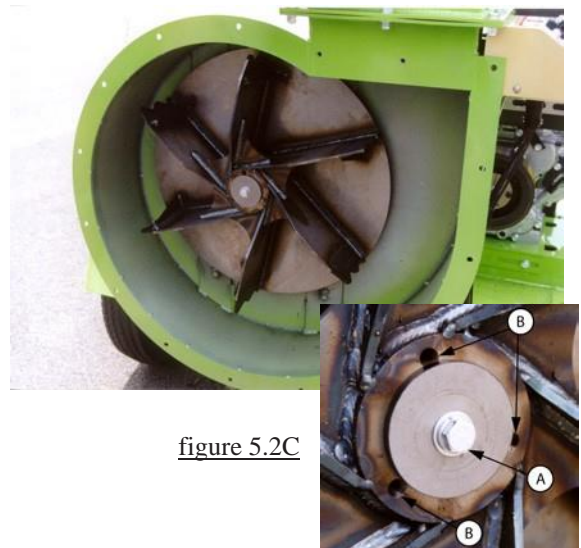

figure 5.2C

# Service Section

## 5.3 Impeller Bearings Removal / Installation

### ⚠ WARNING

Before removing any safety guards make sure the engine has been disabled by removing the lead spark plug wires.

### ⚠ WARNING

Thoroughly read and understand the safety and pre-operating sections of this manual before proceeding.

### ⚠ CAUTION

The engine may be HOT, use caution when working around the engine and muffler area.

### ⚠ CAUTION

Make sure the engine is OFF and the lead spark plug wires have been removed before attempting any service procedures.

### Bearings Removal / Installation :

1. Disconnect the the spark plug wires from the spark plug before attempting to open the blower housing face.
2. Remove the impeller using the procedure outlined in section 5.2.
3. Remove the drive belt using the procedure outlined in section 5.1.
4. Remove the bearing cover by removing the 4 bolts that hold the cover (item A, FIG 5.3A)
5. Loosen the locking collars (Item A, FIG 5.3B) using an Allen wrench, turn the collars counter-clockwise to loosen from the shaft.
6. Remove the nuts (Item B, FIG 5.3B) from the bearings.
7. Slide the entire shaft out. The pulley can stay on the shaft while doing this.
8. Pull the bearings from the bolts.
9. To install, reverse the above procedure.

figure 5.3A

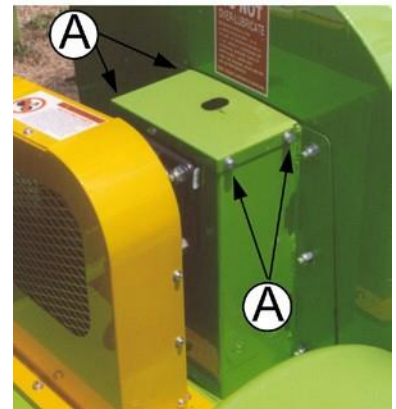
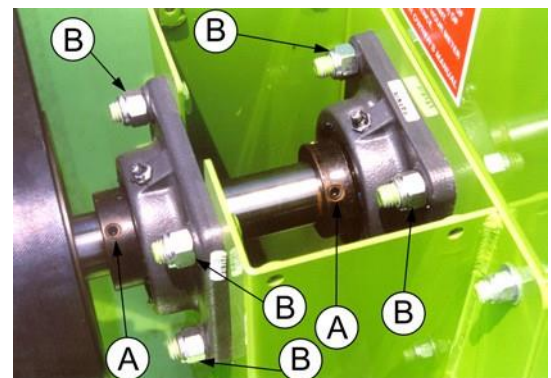

figure 5.3B



# Service Section

## 5.4 Main Circuit Board Plug Diagram

### Main Harness Plug

Pin# Description

1	Red + from battery
2	Red / Blue stripe - starter +
3	Orange - Fuel Sol./Col +
4	Black - Ground
5	Purple Alt Energize +
6	White / Red stripe Oil Signal
7	White - Tach Signal
8	Tan / Black stripeE Stop Sig.
9	Tan - Insp. Door Signal
10	Pink - Fuel Level Signal
11	Blue - Temp Signal
12	Blue/Black Temp Shtdwn Sig
13	Red/Black Oil Shutdown Sig.
14	Empty
15	Empty
16	Empty

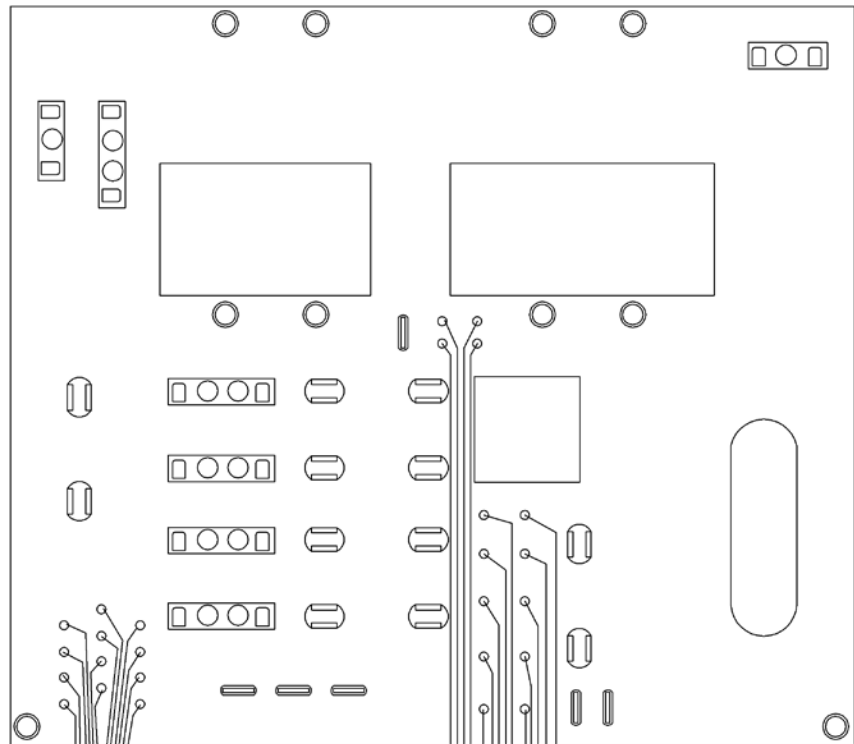

Main Harness Plug

Aux. Harness Plug

### Aux. Harness Plug

Pin# Description

1	Red + from battery
2	Yellow - Aux Plug harness
3	Yellow - Remote Throttle Har
4	Yellow / Orange stripe-Aux har
5	Orange / Yellow stripe-Aux har
6	Yellow / Green stripe-Clutch Eng
7	Empty
8	Green / Yellow stripe-Clutch Diseng
9	Yellow / Blue stripe-Throttle Fast
10	Empty
11	Blue / Yellow stripe-Throttle Slow
12	Yellow / Blue stripe-Strobe +
13	Purple / Yellow stripe-Strobe Sw+
14	Yellow - Aux Harness
15	Black - battery
16	Yellow - Aux Harness

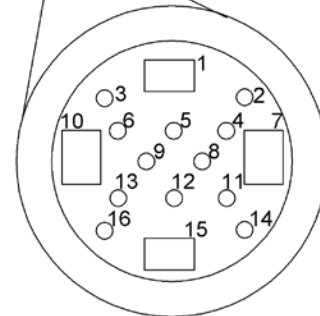
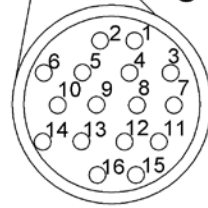

# Service Section

## 5.5 Main Circuit Board Plug Diagram

TOP LAYER

The circuit board has traces on 2 layers - the top and bottom.

### Main Plug Wire ID's

1	+ from Battery (Red)
2	Starter + (Red/Blue)
3	Fuel Sol./Col + (Orange)
4	Ground (Black)
5	Alt Energize + (Purple)
6	Oil Signal (White/Red)
7	Tach Signal (White)
8	E Stop Sig. (Tan/Black)
9	Insp. Door Sig. (Tan)
10	Fuel Level Sig. (Pink)
11	Temp Sig. (Blue)
12	Temp Shtdwn Sig (Blue/Blk)
13	Oil Shutdown Sig. (Red/Blk)

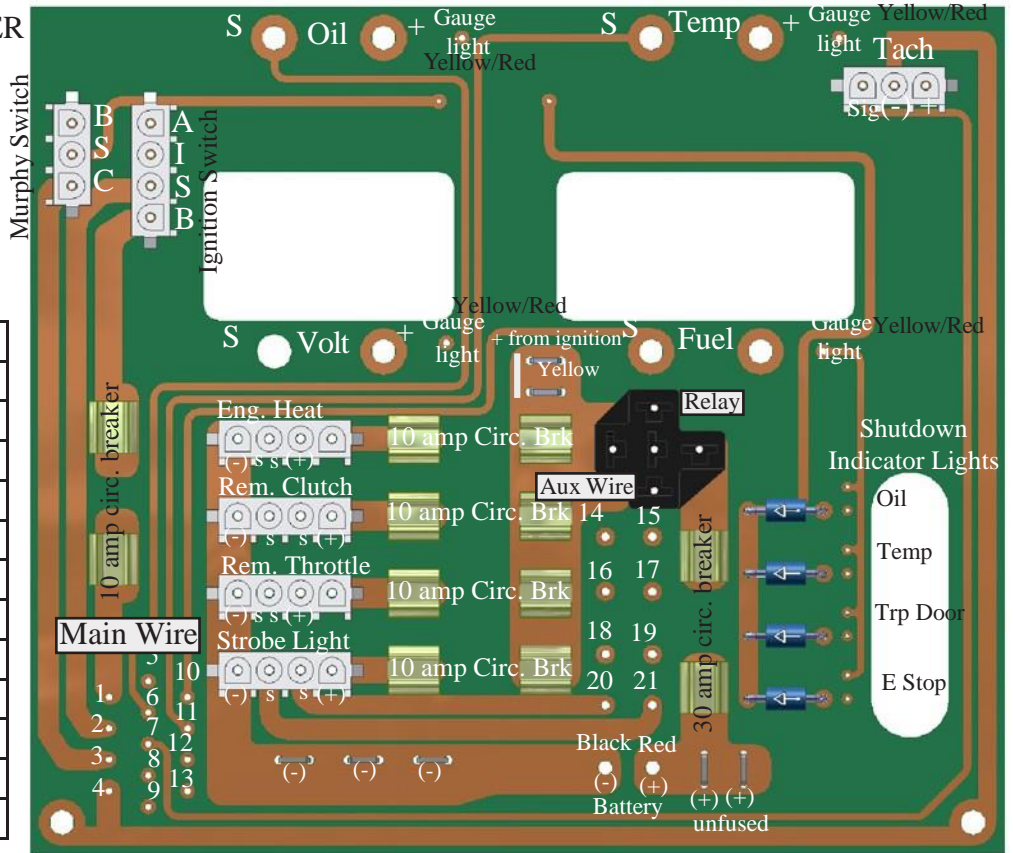

BOTTOM LAYER  
(looking from the back)

### Aux Plug Wire ID's

14	Eng Heat (+) (Yellow/Orange)
15	Eng. Heat Aux (Orange/Yellow)
16	Clutch Engage (Yellow/Green)
17	Clutch Disengage (Green/Yel)
18	Throttle Fast (Yellow/Blue)
19	Throttle Slow (Blue/Yellow)
20	Strobe Light + (Yellow/Purple)
21	Aux Light + (Purple/Yellow)

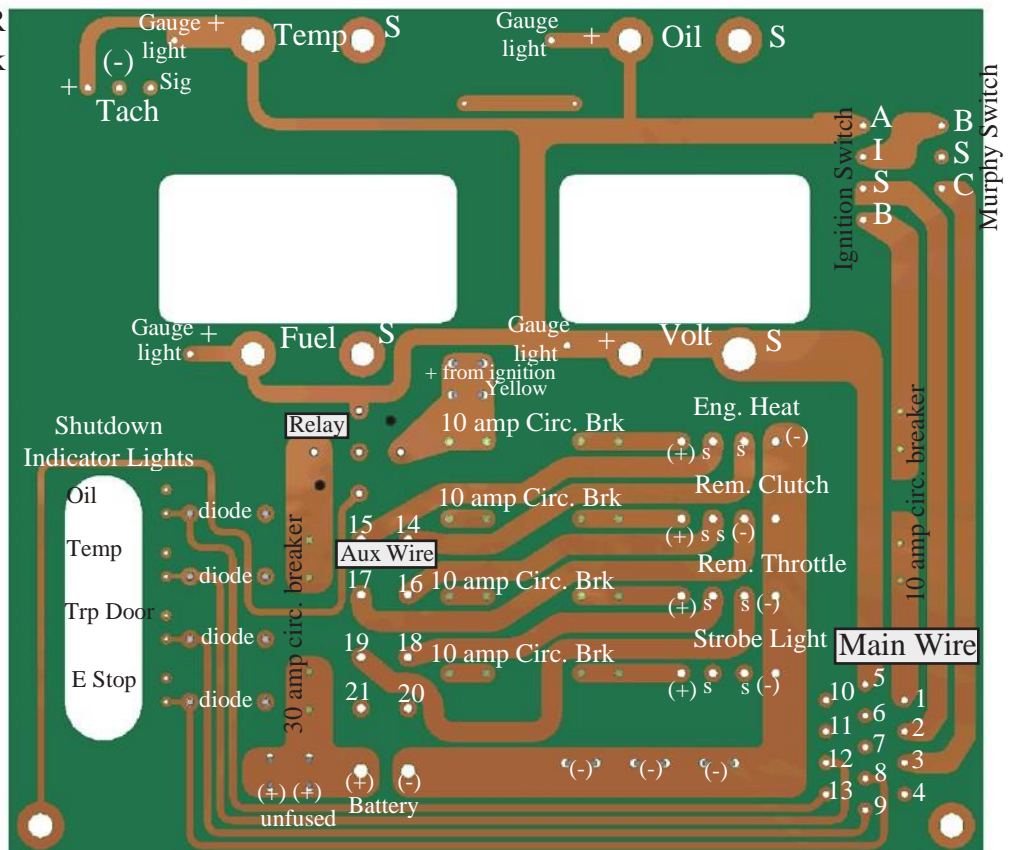

# Service Section

## 5.6 Flow Control Valve Adjustment Instructions

**⚠ DANGER**

**⚠ DANGER**

Before attempting to go under the dump body, make sure the body is completely DOWN. If you must go under a raised body be sure to use the body prop, an overhead crane and sufficient supports rated above the dump container max load rating. These supports must be positioned in a way to assure that the body can not come down. Failure to follow these safety guidelines can result in death or severe personal injury.

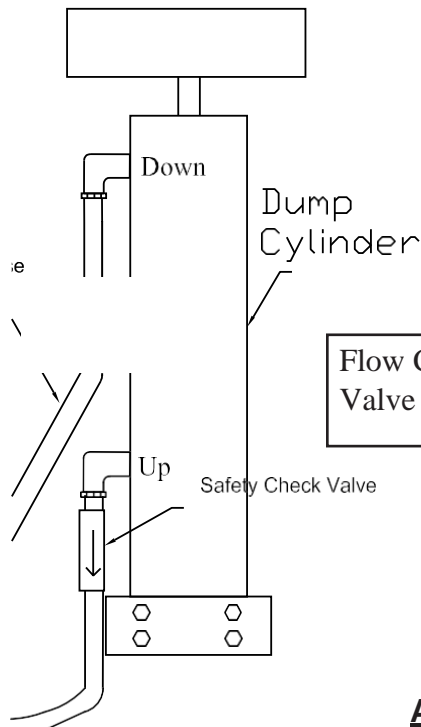

The hoist hydraulic system is equipped with a safety check flow control valve. This valve is used to prevent the body from “crashing” down in the event of a hose failure. The valve may be adjusted if the body becomes difficult to lower. Please note that it is critical that the body is a little difficult to lower the last 12 inches. This is the check valve working properly. Only adjust the check valve if the unit is not lowering at all. The unit is designed to lower slowly for safety reasons.

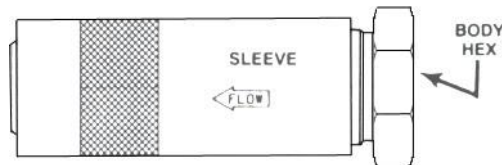

### **Adjustment Instructions:**

1. Install valve in system, downstream of any safety relief valve. USE WRENCH ONLY ON BODY HEX.
2. Loosen set screw and turn sleeve away from body hex as far as possible.
3. Operate system at anticipated flow rate, but with pressure reduced to allow sleeve to be turned by hand.
4. Slowly turn sleeve towards body hex until valve “trips” and stops flow.
5. Relieve inlet pressure, allowing valve to re-open.
6. Turn sleeve away from body hex 1/4 turn. Valve is now adjusted to close when subjected to excessive flow.
7. If valve “trips” during normal operating conditions, re-adjust using 1/2 turn instead of 1/4 turn. See step 6.
8. After final adjustment, tighten set screw on sleeve.

# Service Section

## 5.7 Trailer Plug Wiring Diagram

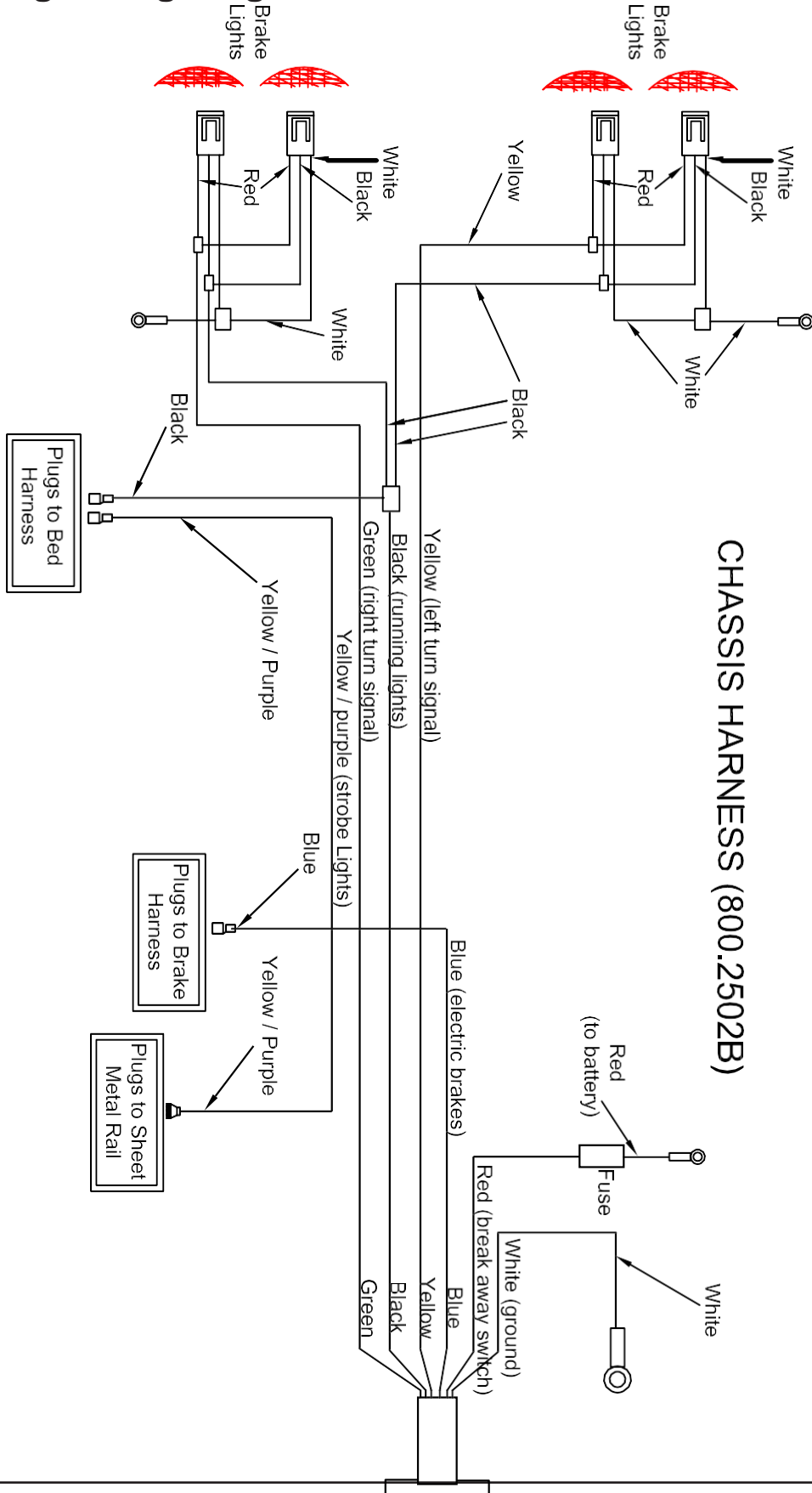



# Service Section

## 5.8 Hoist Hydraulic Schematic

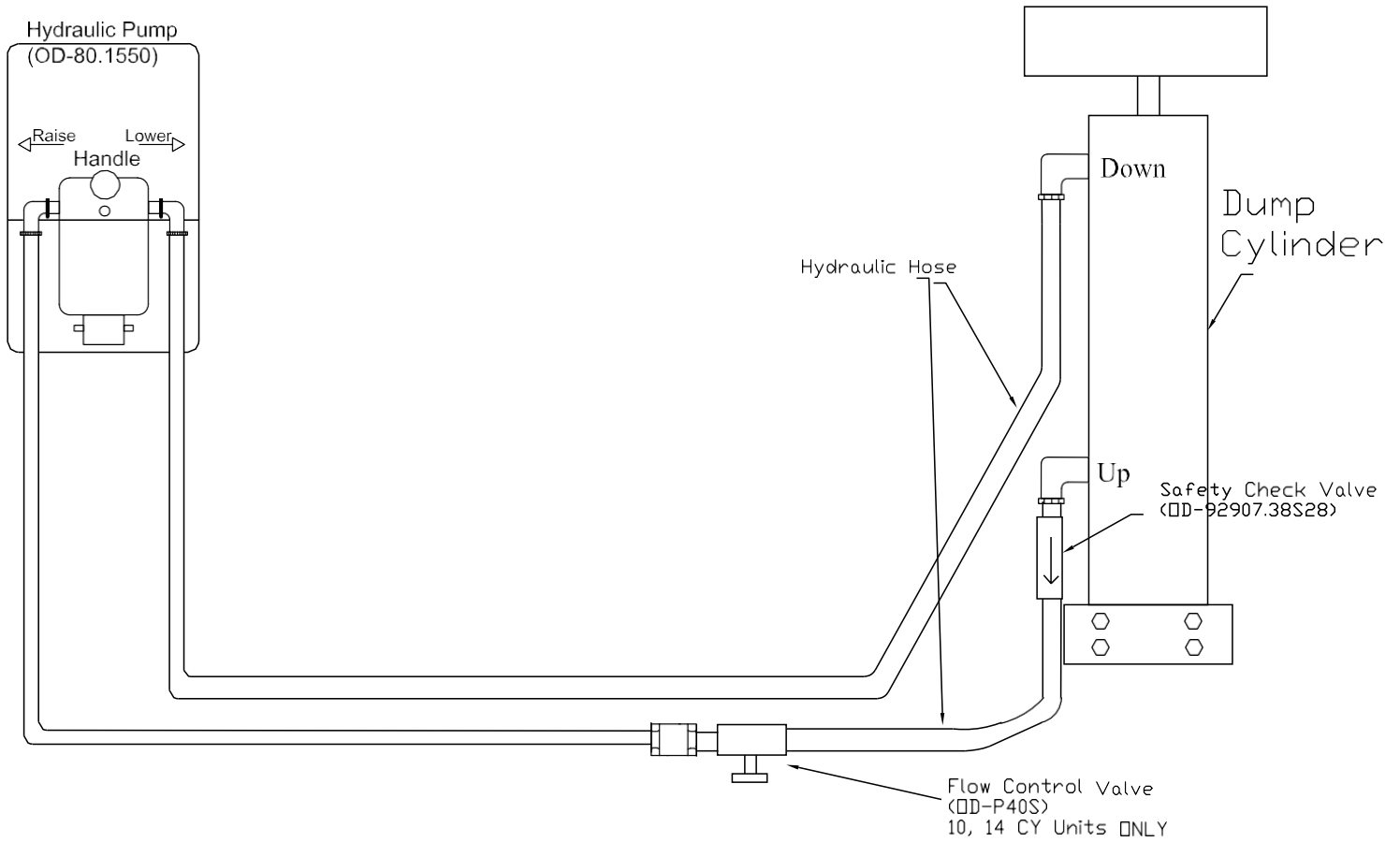



**WARNING**

Read and understand this entire manual before operating, maintaining or repairing the leaf vacuum.

## 6.0 PARTS BREAKDOWNS

### 6.0 PARTS BREAKDOWNS

6.1 Blower Housing Group.....	59
6.2 Instrument Panel Group.....	60
6.3 Engine and Engine Base Group.....	61
6.4 Belt Drive Group - Kubota.....	62
6.5 Belt Engagement Group.....	63
6.6 Kubota Engine Group.....	64
6.7 Tongue Group.....	65
6.8 Hydraulic Pump.....	66
6.8 Hydraulic Pump.....	67
6.9 PTO Group.....	68
6.10 Chassis and Axle Group.....	69
6.11 Hub and Brake Group.....	70
6.12 Box Container Group.....	71
6.13 Light and Reflector Group.....	72
6.14 Rear Door Hardware.....	73
6.15 Intake Hose Group.....	74
6.16 Dump Hoist Group.....	75

**6.0  
PARTS  
BREAKDOWNS**

## 6.1 Blower Housing Group

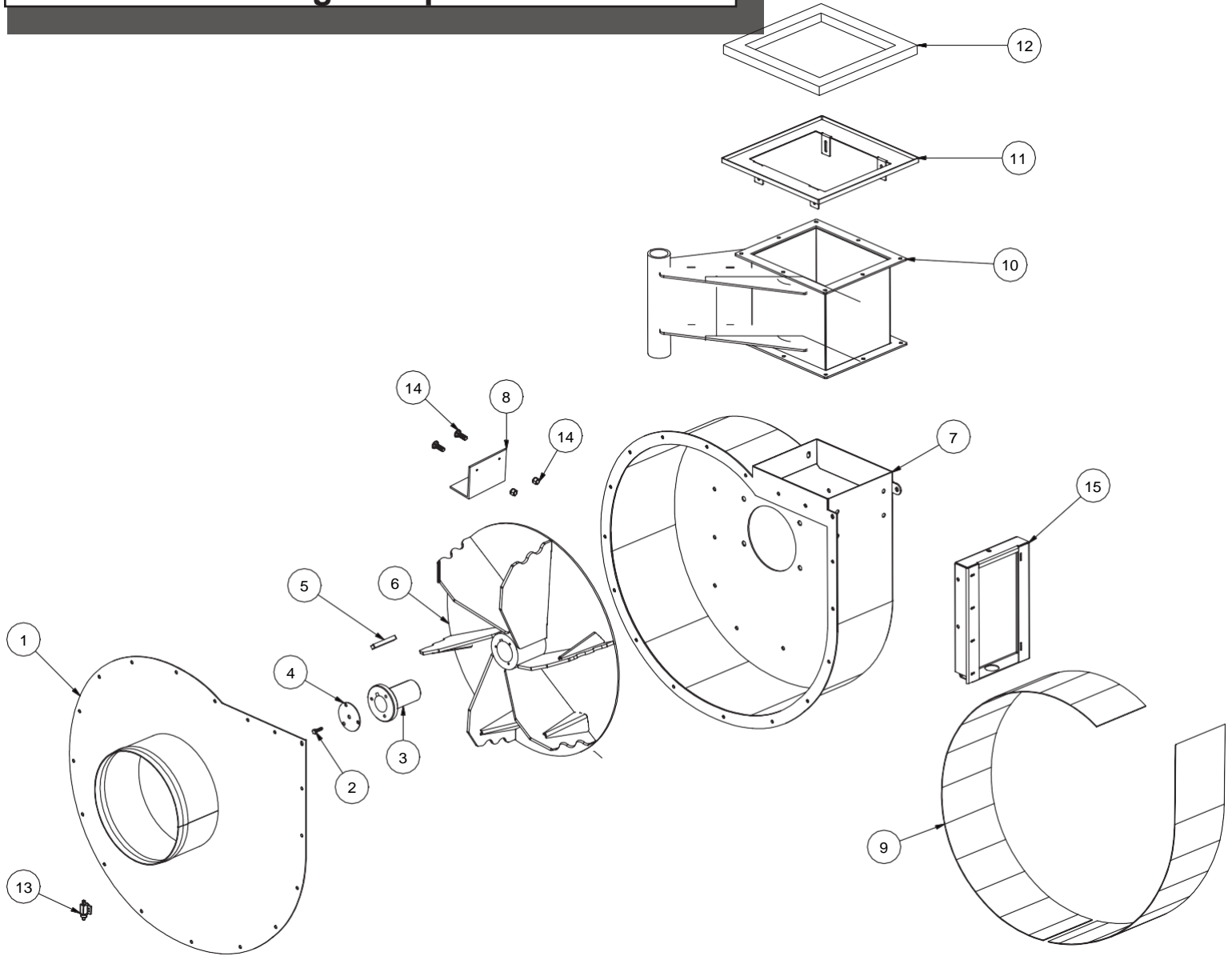

ITEM #	PART NO.	DESCRIPTION	ITEM #	PART NO.	DESCRIPTION
1	65.1002E	Blower Housing Face	10	80.1006	Exhaust Duct
2	65.1005C	Bolt, Impeller	11	80.1007	Exhaust Duct Flange
3	65.1005D	Impeller Bushing	12	80.1007G	Gasket
4	65.1005	Washer, Impeller	13	65.1606B 65.1606C	Limit Switch Limit Switch Cover
5	65.1005B	Key, Impeller	14	65.1002L1B 65.1002L1N	Liner Bolt Liner Nut
6	65.1004C	Impeller	15	450.1501 NS 80.1515	Instrument Panel Mount Panel Mount Bracket
7	65.1002D	Blower Housing Back			
8	65.1002LC	Curved Liner			
9	65.1002L	Large Liner			

## 6.2 Instrument Panel Group

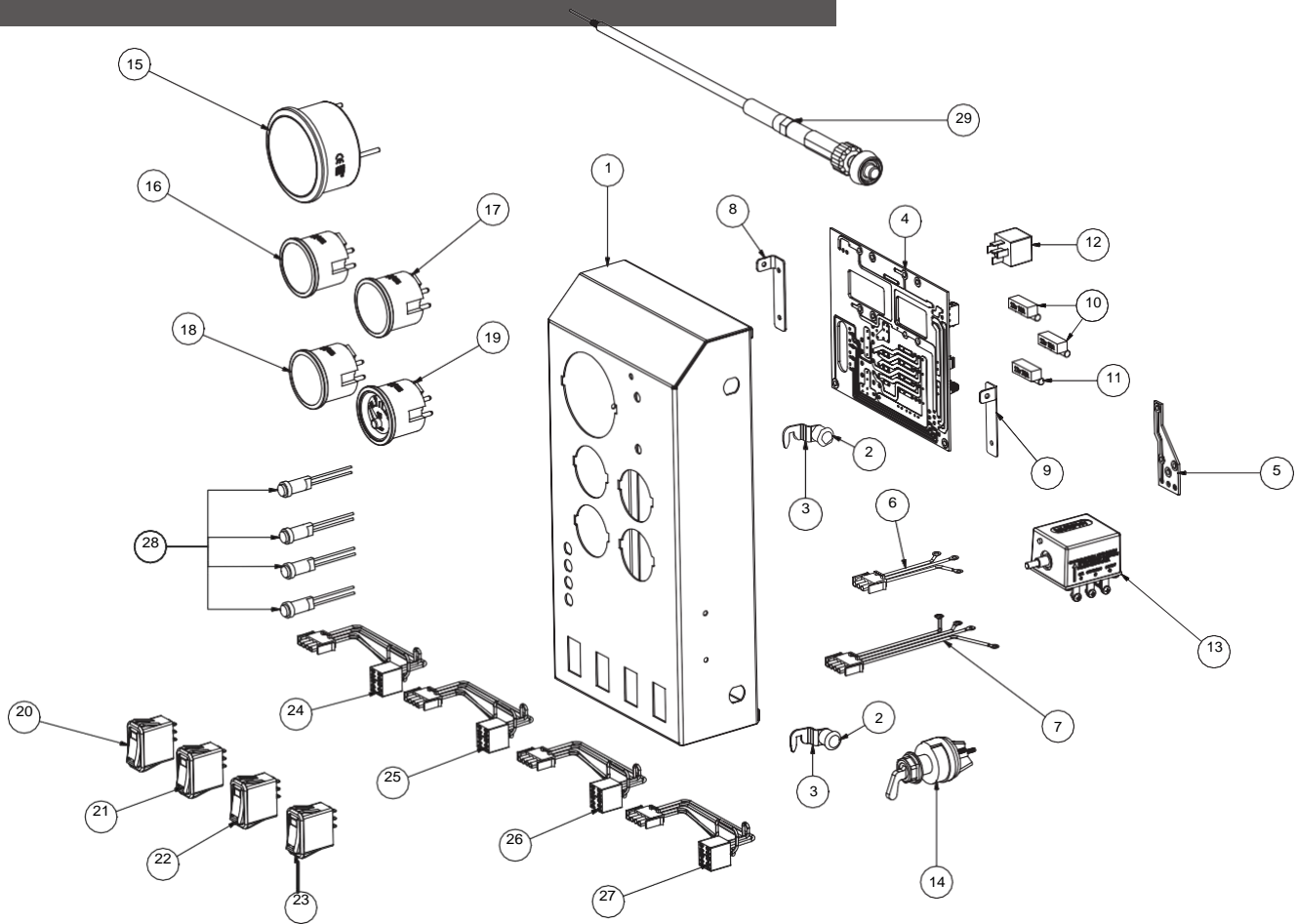

ITEM#	PART NO.	DESCRIPTION
1	2018XZ STD.6301	Instrument Panel Complete Inst.Panel Housing with latches
2	STD.6308	Latch
3	STD.6309	Latch Hook
4	STD.2005	Circuit Board
5	STD.2006	Tachometer Circ. Board
6	400022	Murphy Swith Harness Plug
7	400021	Ign. Switch Harness Plug
8	STD.6303	Circ. Brd Supp Brkt, LH
9	STD.6302	Circ. Brd Supp Brkt, RH
10	100014.10	Circuit Breaker, 10 amp
11	30410.30	Circuit Breaker, 30 amp
12	VF4-15F11	Relay
13	MO-P81505	Murphy Switch
14	31.253	Ignition Switch

ITEM#	PART NO.	DESCRIPTION
15	63524	Tachometer / Hour Meter
16	62540	Temperature Gauge
17	62542	Oil Pressure Gauge
18	62551 59414	Fuel Gauge (if equipped) Blank Gauge
19	62555	Volt Meter
20	4045.0021B1	Rocker Switch,Safety Light
21	4045.0021A1	Rocker Switch, Rem. Thrrtle
22	4045.0025A	Rocker Switch, Rem. PTO
23	3054.0028.	Rocker Switch, Engine Heat
24	STD.2003	Switch Harness, Light
25	STD.2004	Switch Harness, Rem Thrrtle
26	STD.2004	Switch Harness, Rem PTO
27	STD.2002	Switch Harness, Eng Heat
28	STD.1502B	LED Light Assembly
29	LCT623.001A	Throttle Cable

## 6.3 Engine and Engine Base Group

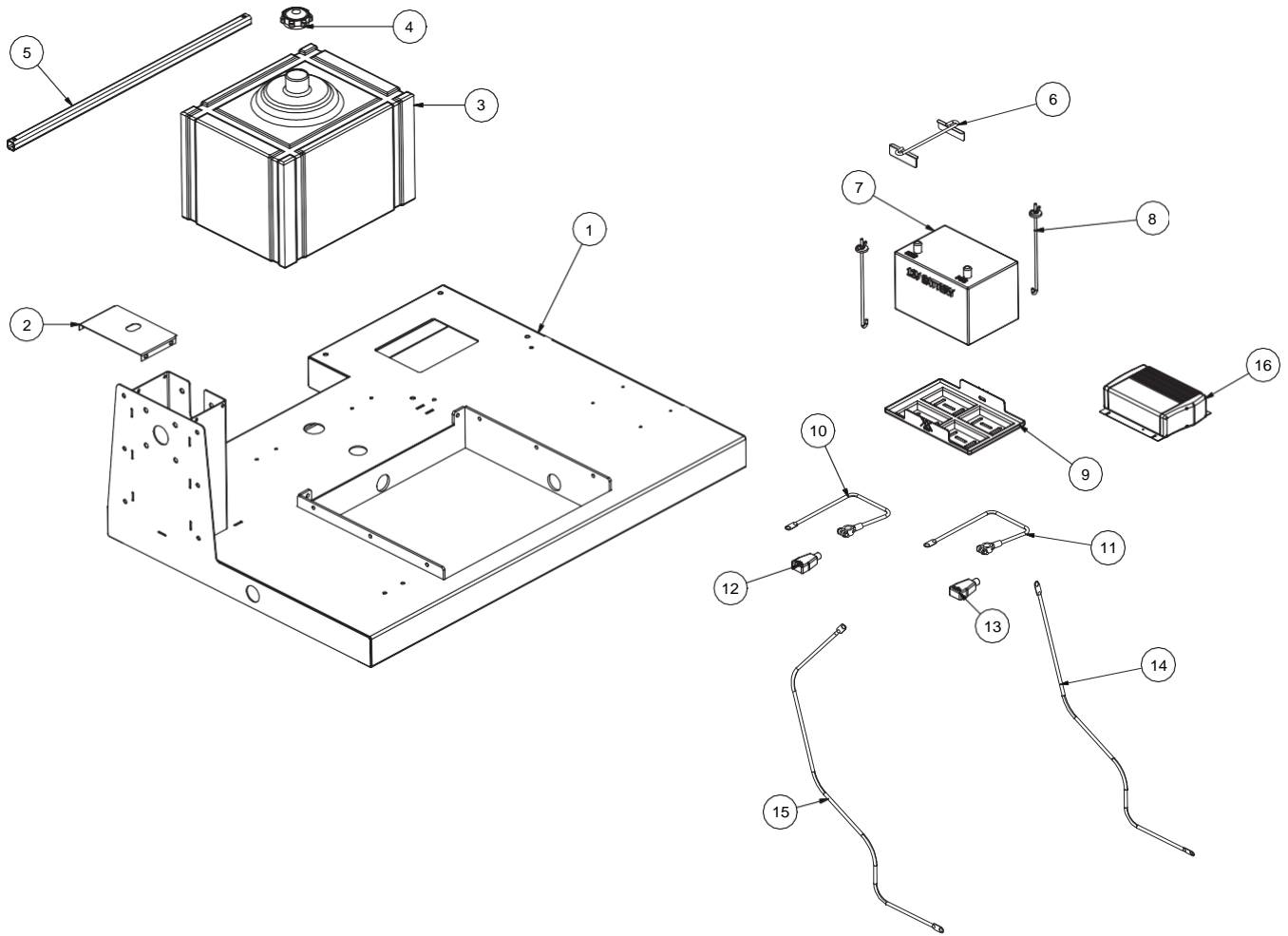

ITEM #	PART NO.	DESCRIPTION	ITEM #	PART NO.	DESCRIPTION
1	80.1001AA	Engine Skid	9	80.1301	Battery Tray
2	65.1011B	Pedestal Lid	10	JD4045.12SS	Cable, 12" red
3	65.1106	Fuel Tank	11	LCT60.15B	Cable, Ground
4	65.1102B	Fuel Cap	12	65.1306	Terminal Cover Red
5	80.1008	Blower Housing Support Bar	13	65.1307	Terminal Cover Black
6	BHCB	Battery Holddown Bar	14	SCL.42B	Cable, Starter
7	80.1300	Battery	15	600.84R	Cable, 84" red
8	BHB10J	Battery J-Hooks	16	80.1306	Battery Charger

## 6.4 Belt Drive Group - Kubota

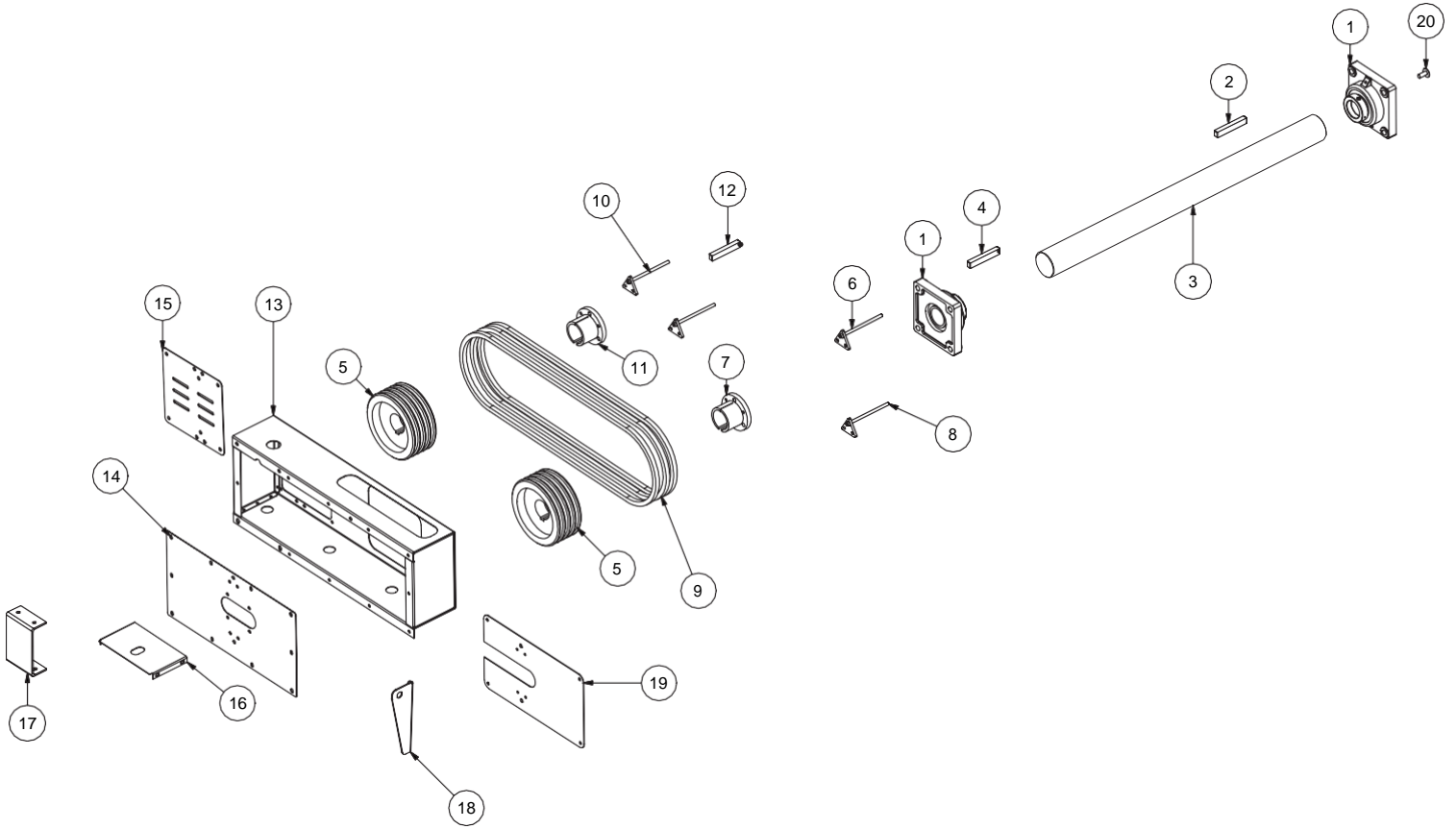

ITEM #	PART NO.	DESCRIPTION	ITEM #	PART NO.	DESCRIPTION
1	65.1406	Drive Bearings	12	65.1404B	Key, Bushing Engine
2	65.1005B	Key, Impeller	13	65.1400G	Belt Guard
3	65.1405B	Shaft	14	65.1400D1	Guard Back Cover
4	65.1403B	Key, Pully Bushing	15	65.1400H	Guard Front Cover
5	65.1402	Pulley	16	65.1011B	Pedistal Cover
6	65.1408	Belt Keeper, Top Impeller	17	65.1400F	Belt Guard Support
7	65.1403	Bushing, Impeller	18	KUB.1221	Throttle Cable Bracket
8	65.1409	Belt Keeper, Bottom Impeller	19	KUB.1224	Shield Plate
9	65.1401B	Drive Belt	20	65.1005C	Shaft Bolt
10	65.1409	Belt Keeper, Engine			

# Parts Section

11	65.1404	Bushing, Engine
----	---------	-----------------

## 6.5 Belt Engagement Group

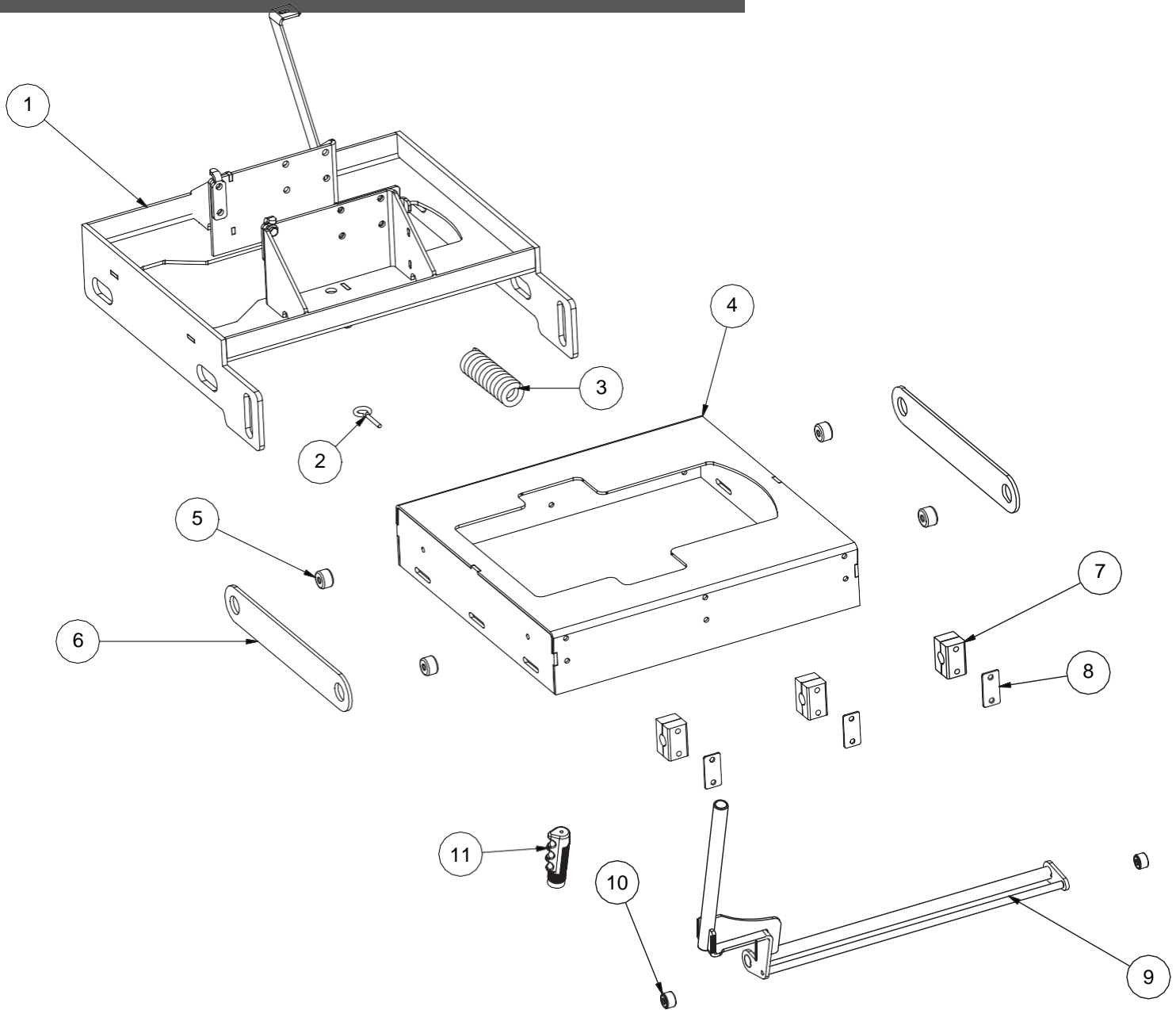

ITEM #	PART NO.	DESCRIPTION	ITEM #	PART NO.	DESCRIPTION
1	80.1003KUB	Motor Mount	7	65.1003E	UHMW Block
2	65.1003L	Eye Bolt	8	65.1003F	Bolt Plate
3	65.1003K	Tension Spring	9	65.1003CC	Engage Handle
4	80.1003AA	Motor Base	10	LCT676	Roller Bearing
5	65.1003G	Cam follower 1.25	11	SCL670.5	Grip
6	80.1003I	Side Shims			



# Parts Section

## 6.6 Kubota Engine Group

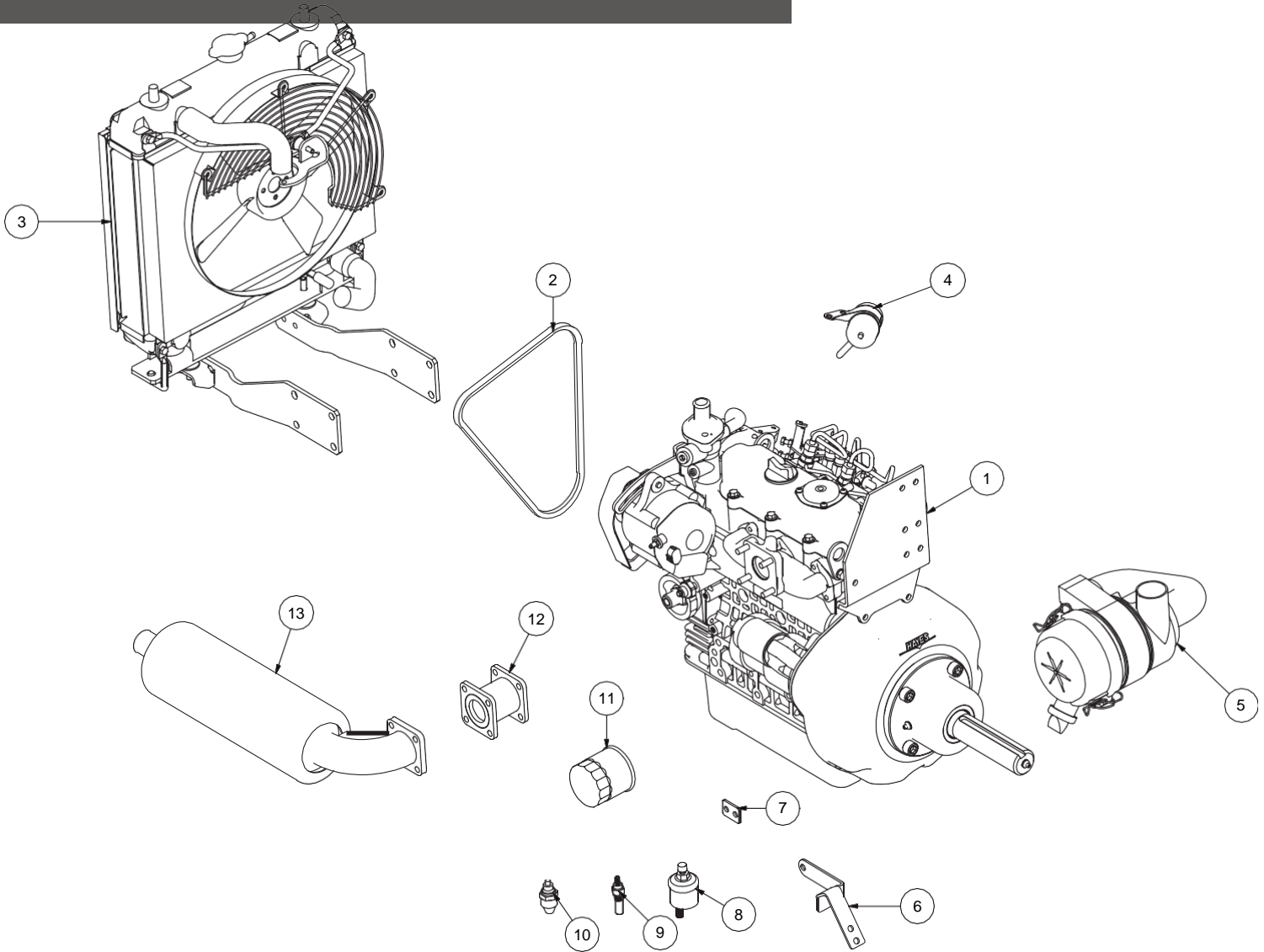

ITEM #	PART NO.	DESCRIPTION	ITEM #	PART NO.	DESCRIPTION
1	KUB25	Kubota 25HP Diesel	10	KUB.1213	Temp Sender
2	KUB.1217	V Belt	11	KUB.1209	Oil Filter
3	KUB.1218	Radiator Assembly	12	KUB.1220	Exhaust Extension
4	KUB.1216	Solenoid		KUB.1208	Gasket
5	KUB.1211	Air Filter	13	KUB.1219	Muffler
6	KUB.1222	Throttle Cable Clamp Mount	NS	KUB.1200	Engine Harness
7	KUB.1223	Throttle Cable Clamp Plate		KUB.1210	Fuel Filter
8	KUB.1214	Oil Pressure Sender			
9	KUB.1215	Temp Switch			

## 6.7 Tongue Group

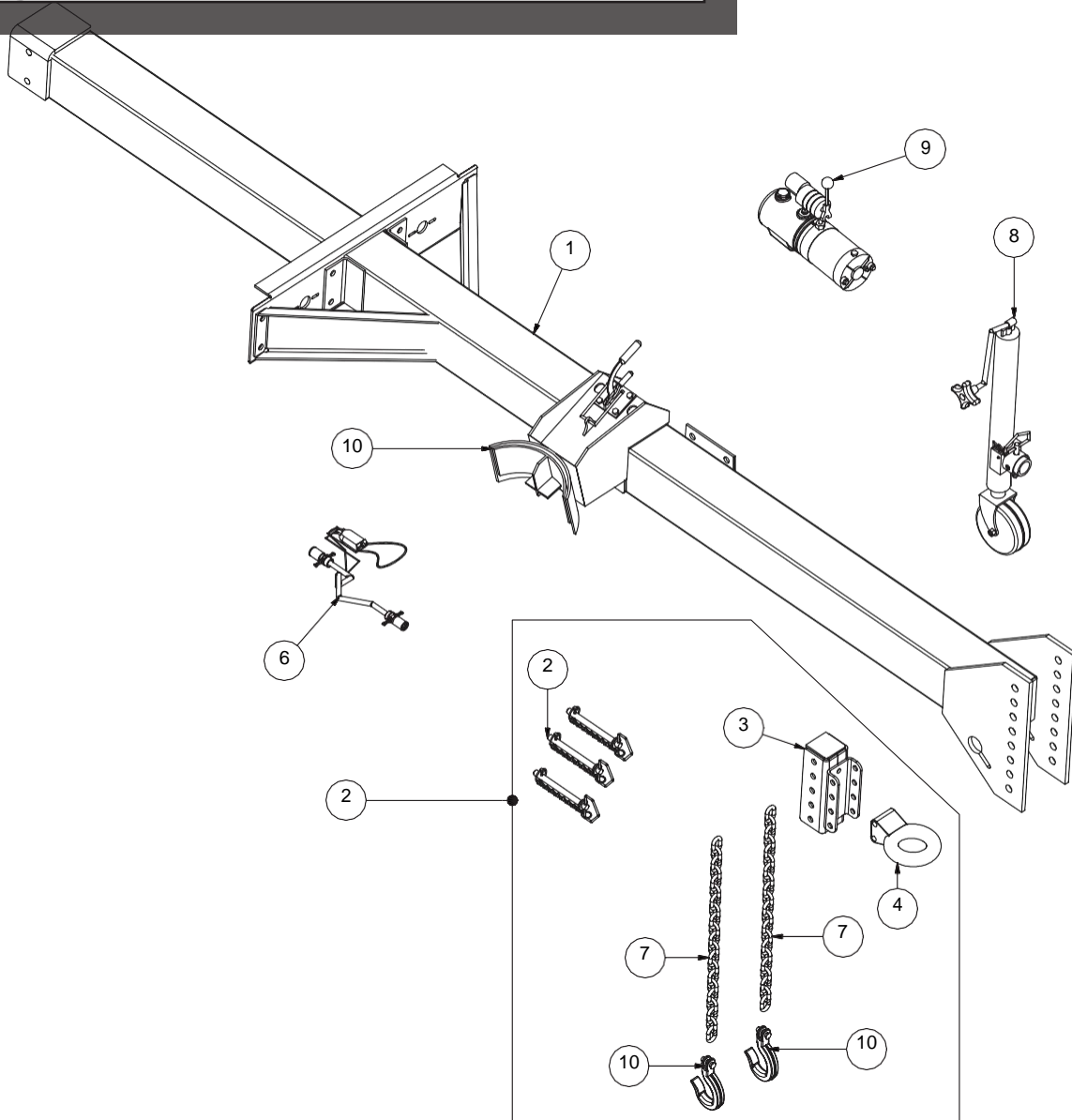

ITEM #	PART NO.	DESCRIPTION
1	80.1099	Tongue
2	LCT622.623D	Pintle Eye Assembly
3	LCT622.623A.2	Block
4	LCT622.623	Ring
5	200012	Pins
6	80.1652	Power Cord
7	SCL800.625	Safety Chains
8	80.1103	Parking Jack
9	MPM33100120	Hydraulic Pump
10	80.1100	Nozzle Tray

Entire Pump Assembly:  
MPM33100120

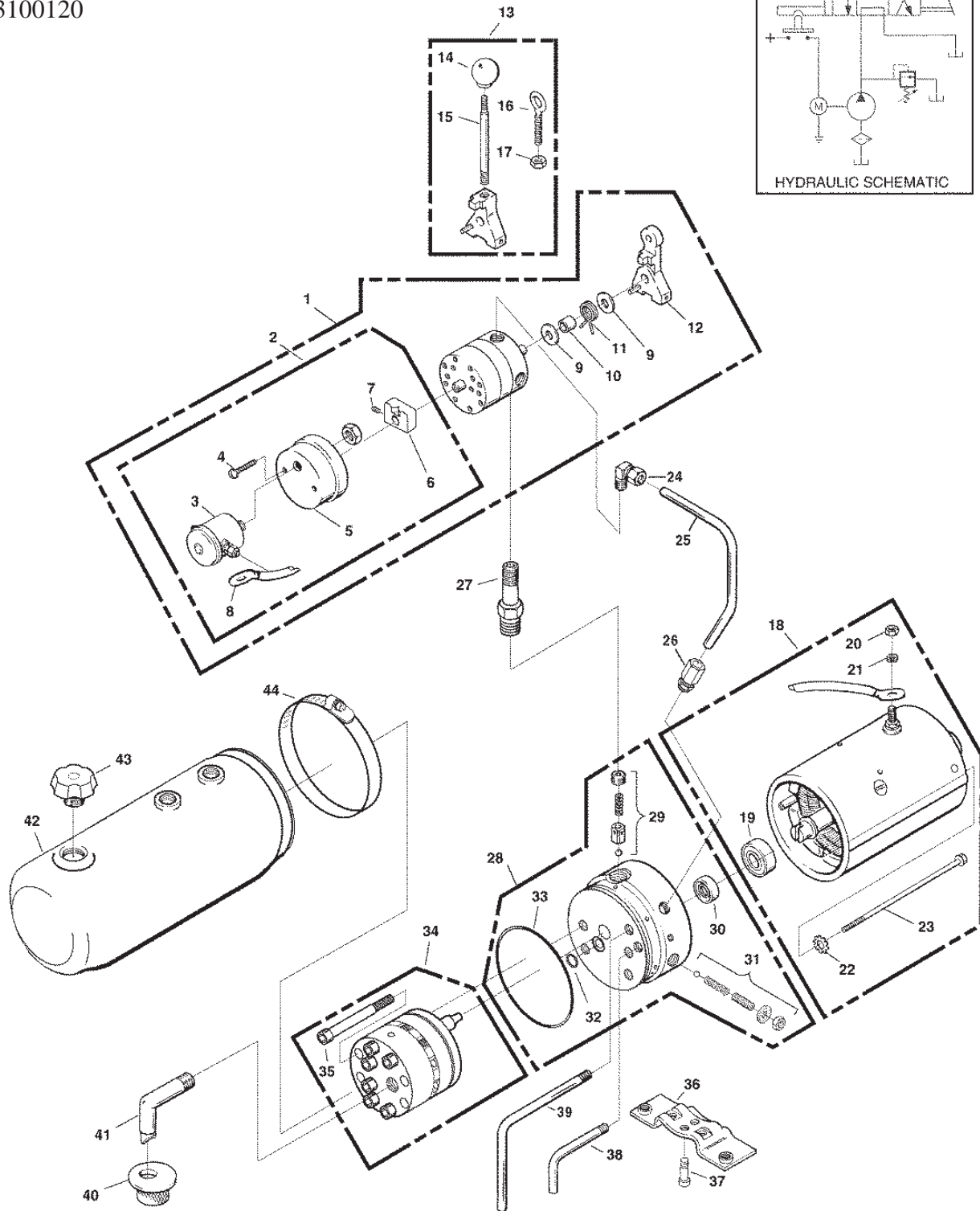

ITEM NO.	PART NUMBER	DESCRIPTION	ITEM NO.	PART NUMBER	DESCRIPTION
1	07120	VALVE ASSEMBLY COMPLETE 1	24	01225	ELBOW ASSEMBLY, 90 Deg
2	04202	• PARTS KIT, Switch Assembly	25	13065	TUBE, Return 1
3	04343	•• SWITCH, Start	26	01231	CONNECTOR ASSEMBLY 1
4	07908	•• SCREW, Mach, pan head 2	27	01318	ADAPTER, Pump/Valve
5	04344	•• COVER, Start Switch 1	28	12450	BASE ASSEMBLY, Modular 1
6	04342	•• CAM, Start Switch 1	29	07526	• PARTS KIT, Check Valve (main) 1
7	07909	•• SCREW, Socket Set, 5/16-18 1	30	02159	• SEAL 1
8	04322	•• CABLE 1	31	03766	• PARTS KIT, Relief Valve 1
9	07780	• WASHER, Flat, (bore 5/16") 2	32	00120	• O-RING, Industrial
10	00016	• BUSHING, Torsion Spring 1	33	02352	• O-RING, Industrial
11	00018	• SPRING, Torsion 1	34	K12171-250	PUMP ASSEMBLY, Modular 1
12	01077	• HANDLE ASSEMBLY 1	35	07818	• SCREW, 1/4-20 x 3 S Head Cap 4 (For Pump Assembly -250)
13	00172	• HANDLE ASSEMBLY 1	36	04559	BRACKET, Plate Mount 5" C to C 1
14	01157	•• BALL, Plastic 1		04560	BRACKET, Plate Mount
15	01326	•• ROD, Handle 4" 1	37	07592	SCREW, Skt Hd Cap, 3/8-16 x 1 2
16	01327	•• EYEBOLT, Rod Control	38	13059	TUBE, Return (1/8" NPT) 1
17	07790	•• NUT, 5/16-18 1	39	13058	TUBE, Return (1/8" NPT) 1
FOR FURTHER BREAKDOWN OF VALVE, SEE VALVE SECTION			40	01134	SCREEN, Filter (suction) 1
18	08111	MOTOR, Electric, 12 VDC 1	41	01209	TUBE, Filter Suction 3/8" NPT
19	02318	• BEARING, Base, motor 1	42	06102	RESERVOIR, 4-1/2" Dia. x 8",
20	07625	• NUT, Hex, 5/16-24 1	43	03171	PLUG, Vent, 3/8" NPT 1
21	07781	• WASHER, Lock, 5/16" 1	44	07900	CLAMP 1
22	07737	• WASHER, Star, 1/4" 4			
23	07738	• SCREW, Hex Head Cap			
FOR FURTHER BREAKDOWN OF MOTOR, SEE MOTOR SECTION					

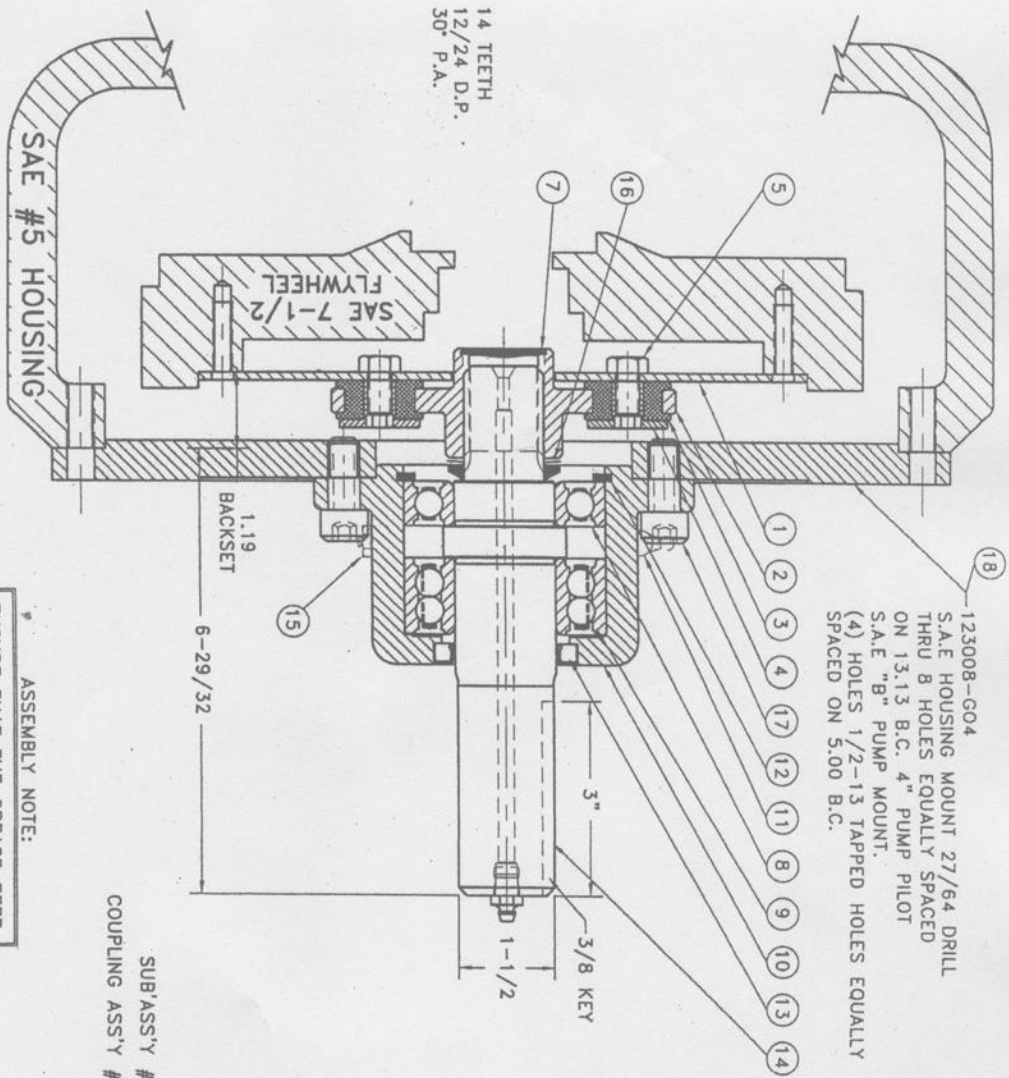

18 123008-G04  
 S.A.E HOUSING MOUNT 27/64 DRILL  
 THRU 8 HOLES EQUALLY SPACED  
 ON 13.13 B.C. 4" PUMP PILOT  
 S.A.E "B" PUMP MOUNT.  
 (4) HOLES 1/2-13 TAPPED HOLES EQUALLY  
 SPACED ON 5.00 B.C.

ASSEMBLY NOTE:  
 ENSURE THAT THE GREASE ZERT  
 AND RELIEF VALVE ARE LOCATED  
 HORIZONTAL WHEN MOUNTING ON  
 TO PUMP MOUNT PLATE.

SUB'ASS'Y #126088  
 COUPLING ASS'Y #125052

- NOTES:
1. LIGHT GREASE INTERNAL AND EXTERNAL AREA OF SPLINE AT ASSEMBLY USING SUPPLIED COUPLING GREASE (OVER GREASING COULD CAUSE A HYDRAULIC TYPE LIFT ON SEALS).
  2. AT ASSEMBLY GREASE BEARING HOUSING UNTIL PIN EXTENDS FROM PRESSURE RELIEF VALVE (LOCATED 180° FROM GREASE ZERT). USE OF AN UNLEADED EXTREME PRESSURE LITHIUM GREASE WITH NLGI NO.2 GRADE IS RECOMMENDED. RUN TIME BETWEEN GREASINGS NOT TO EXCEED 2,000 HOURS.
  3. WARNING!! INJURY OR DEATH FROM A ROTATING STUB SHAFT CAN OCCUR IF A CONDITION EXISTS WHICH WOULD CAUSE THE SHAFT TO BREAK OR COME APART FROM ANY PART OF THE ASSEMBLY. DEPENDING UPON THE APPLICATION (FOR EXAMPLE, FAN, PULLEY, SHEAVE, ETC.). THE AREA AROUND THE STUB SHAFT MUST BE SUFFICIENTLY GUARDED SO THAT IN THE EVENT OF FAILURE, THE GUARD WILL CONTAIN ANY AIRBORNE PARTS.

QTY.	PART NUMBER	DESCRIPTION	QTY.
1	18 123008-G04	PUMP MOUNT PLATE	1
4	17 740000	1/2-13x1-1/8 SHCS	4
1	16 VS-032	V-RING	1
1	15 1083K11	RELIEF VALVE	1
1	14 126087	SPLINED SHAFT	1
1	13 CRW1 R 15830	SEAL	1
1	12 RR-314	SNAP RING	1
2	11 6000000	GREASE ZERT	2
1	10 125007	BEARING HOUSING	1
1	9 5208WD	DOUBLE BEARING	1
1	8 208P	BEARING	1
1	7 R-0017-01	GREASE PLUG	1
1	6 801912	GREASE	1
8	5 HX100	5/16-24x5/8 HHB	8
8	4 123728-01	THREADED BUSHING	8
8	3 H52500	NEOPRENE INSERT	8
1	2 125008	COUPLING HUB	1
1	1 123243-97	FLYWHEEL PLATE	1

**SYMBOLS**

STRAIGHTNESS  
 SURFACE FINISH  
 HOLE POSITION  
 PERPENDICULARITY  
 CHAMFER  
 TOTAL RUN OUT  
 CIRCULARITY  
 PROFILE

UNLESS OTHERWISE SPECIFIED -  
 BREAK ALL SHAFT CONES 2:1 TO .020  
 BREAK ALL TAPPED HOLES  
 SHOWN ON THIS DRAWING 1:1

**HAYES**  
 MANUFACTURING, INC.®

**BEARING SUPPORTED STUB SHAFT ASSY**

DATE: 1-15-01  
 DRAWING NO.: 126171  
 SHEET OF REV.

THIS DRAWING IS THE PROPERTY OF HAYES MFG. INC. AND IS LOANED TO YOU FOR YOUR INFORMATION ONLY. IT IS NOT TO BE REPRODUCED OR TRANSMITTED IN ANY FORM OR BY ANY MEANS, ELECTRONIC OR MECHANICAL, INCLUDING PHOTOCOPYING, RECORDING, OR BY ANY INFORMATION STORAGE AND RETRIEVAL SYSTEM. IT IS TO BE USED AS A GUIDE OF REFERENCE TO WORK FABRICATED BY HAYES MFG. INC. AND IS NOT TO BE SUBMITTED TO OTHER PARTS FOR EVALUATION WITHOUT OUR CONSENT.

RIGHT ©2000-2008 by Hayes Manufacturing, Inc. All rights reserved.

## 6.10 Chassis and Axle Group

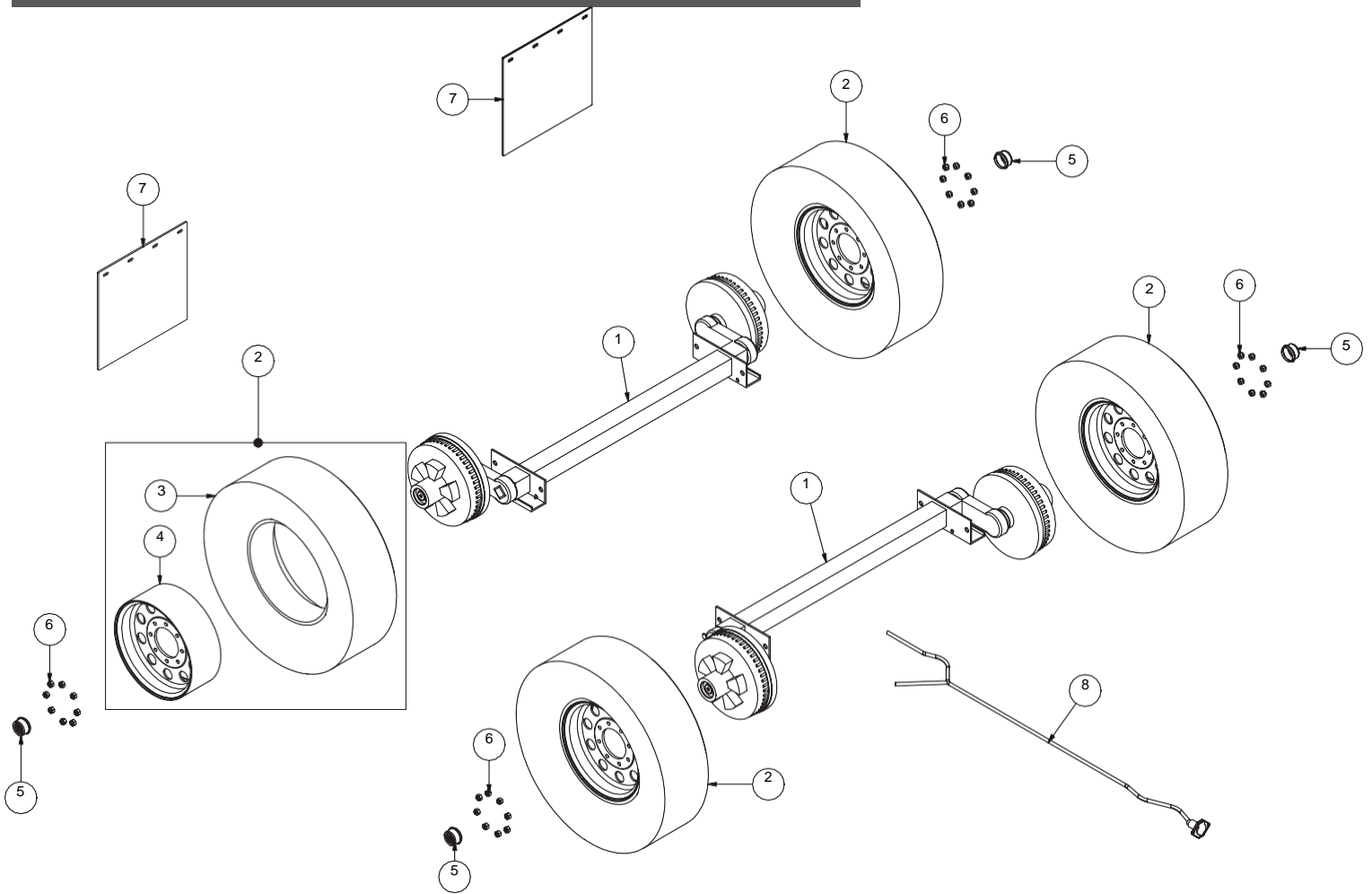

ITEM #	PART NO.	DESCRIPTION
1	80.1104	Axle
2	LCT622.619	Tire and Rim Assembly
3	LCT622.619T	Tire
4	LCT622.619R	Rim
5	021.042.01	Grease Cap
6	LCT622.619N	Lug Nut
7	80.0057	Mud Flap
8	80.1651C 80.1655A	Chassis Wiring Harness Bed Wiring Harness

## 6.11 Hub and Brake Group

### Hub Breakdown

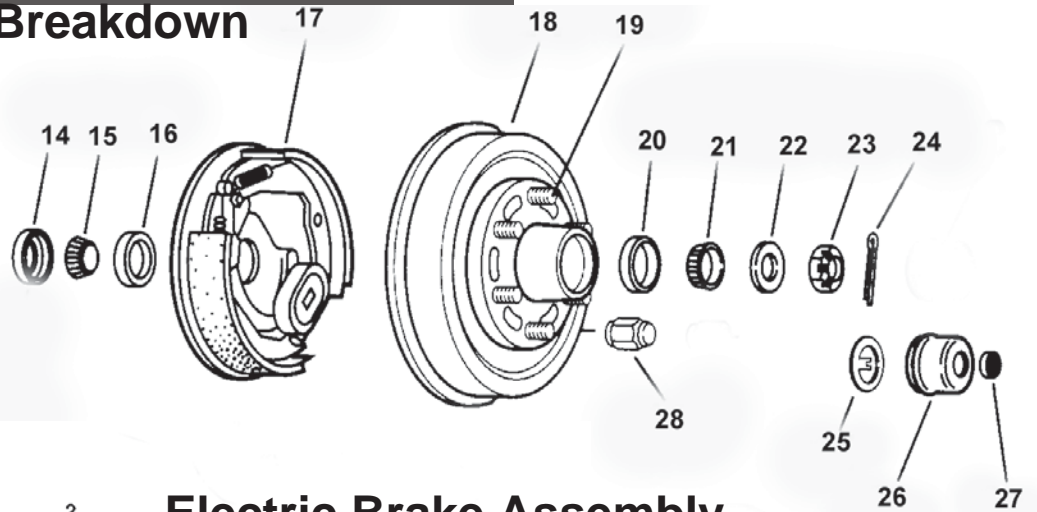

### Electric Brake Assembly

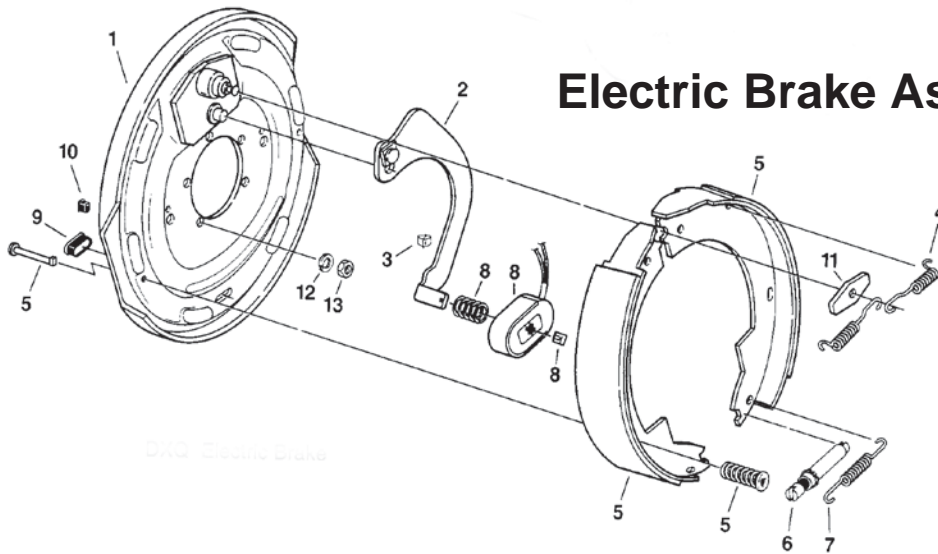

ITEM NO.	PART NUMBER	DESCRIPTION	ITEM NO.	PART NUMBER	DESCRIPTION
*	023.105.00	Complete Brake Assembly LH	14.	10.10	Grease Seal
*	023.106.00	Complete Braek Assembly RH	15.	031.030.02	Inner Bearing Cone
1.	036.089.05	Backing Plate Assembly	16.	031.030.01	Inner Bearing Cup
2.	047-107-00	Actuating Lever Arm Assembly LH	17.	023.105.00	Electric Brake Assembly LH
2.	047-108-00	Actuating Lever Arm Assembly RH		023.106.00	Electric Brake Assembly, RH
3.	027-005.00	Wire Clip	18.	008.201.09	Grease Hub & Drum
4.	046.009.00	Retractor Spring	19.	007.122.00	Wheel Stud
5.	k71.048.00	Shoe and Lining Kit	20.	031.032.01	Outer Bearing Cup
6.	043.004.00	Adjuster Assembly	21.	031.032.02	Outer Bearing Cone
7.	046.018.00	Adjusting Screw Spring	22.	005.023.00	Sprindle Washer
8.	k71.105.00	Magnet Kit	23.	006.001.00	Spindle Nut
9.	046.007.00	Plug	24.	N/A	Not Used
10.	046.016.00	Wire Grommet	25.	005.101.00	Tang Washer
11.	005.067.00	Anchor Post Washer	26.	021.042.01	Grease Cap, without plug
12.	005.004.00	Lockwasher	27.	085.001.00	Rubber Plug
13.	006.010.00	Brake Mounting Nut	28.	LCT622.619N	Lug Nut

## 6.12 Box Container Group

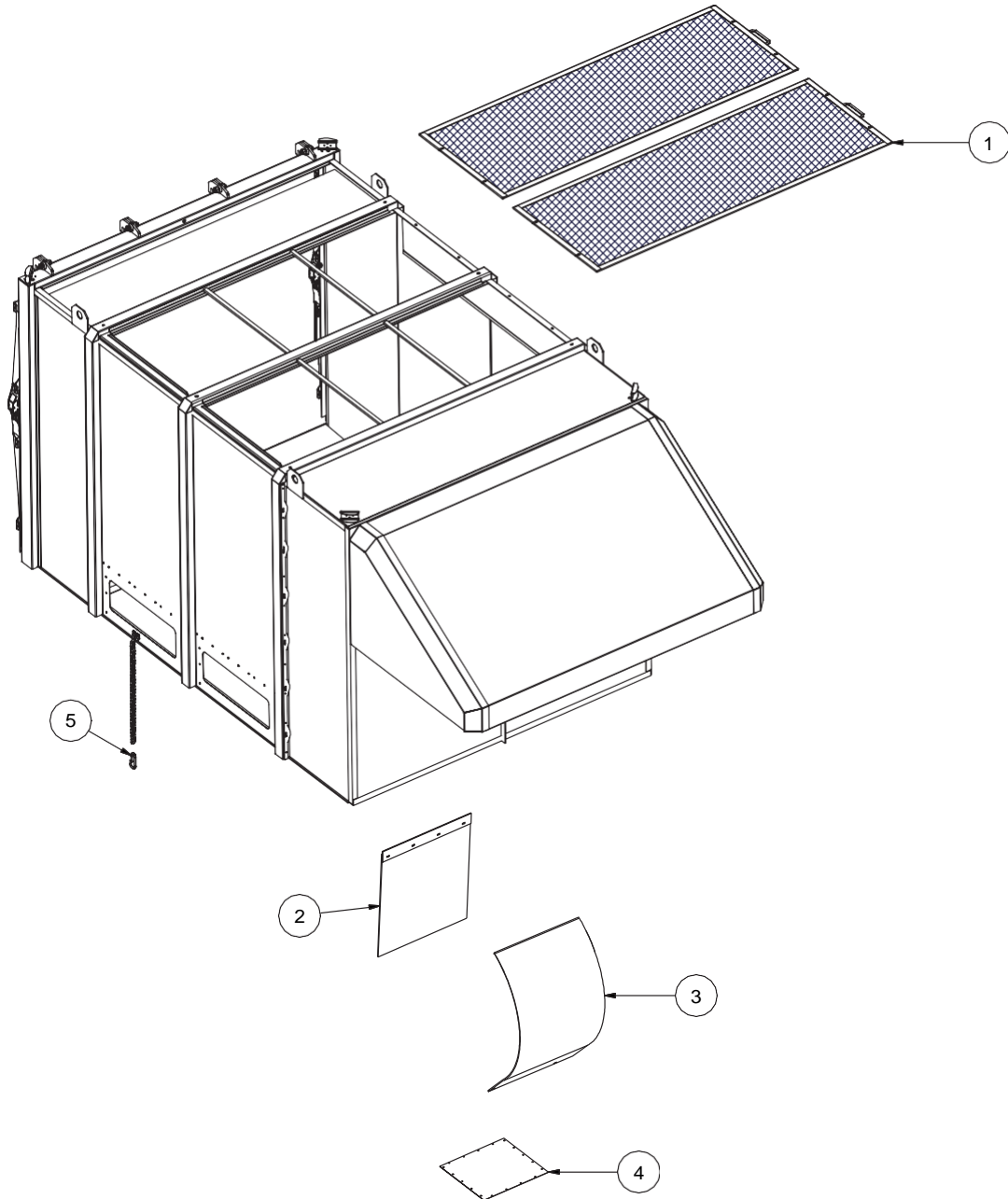

ITEM #	PART NO.	DESCRIPTION
1	SCL805.810	Exhaust Screen
2	SCL800.811	Deflector Rubber Flap
3	80.0059	Deflector Liner
4	80.0058	Cover Plate
5	200008	Spring Clip



## 6.13 Light and Reflector Group

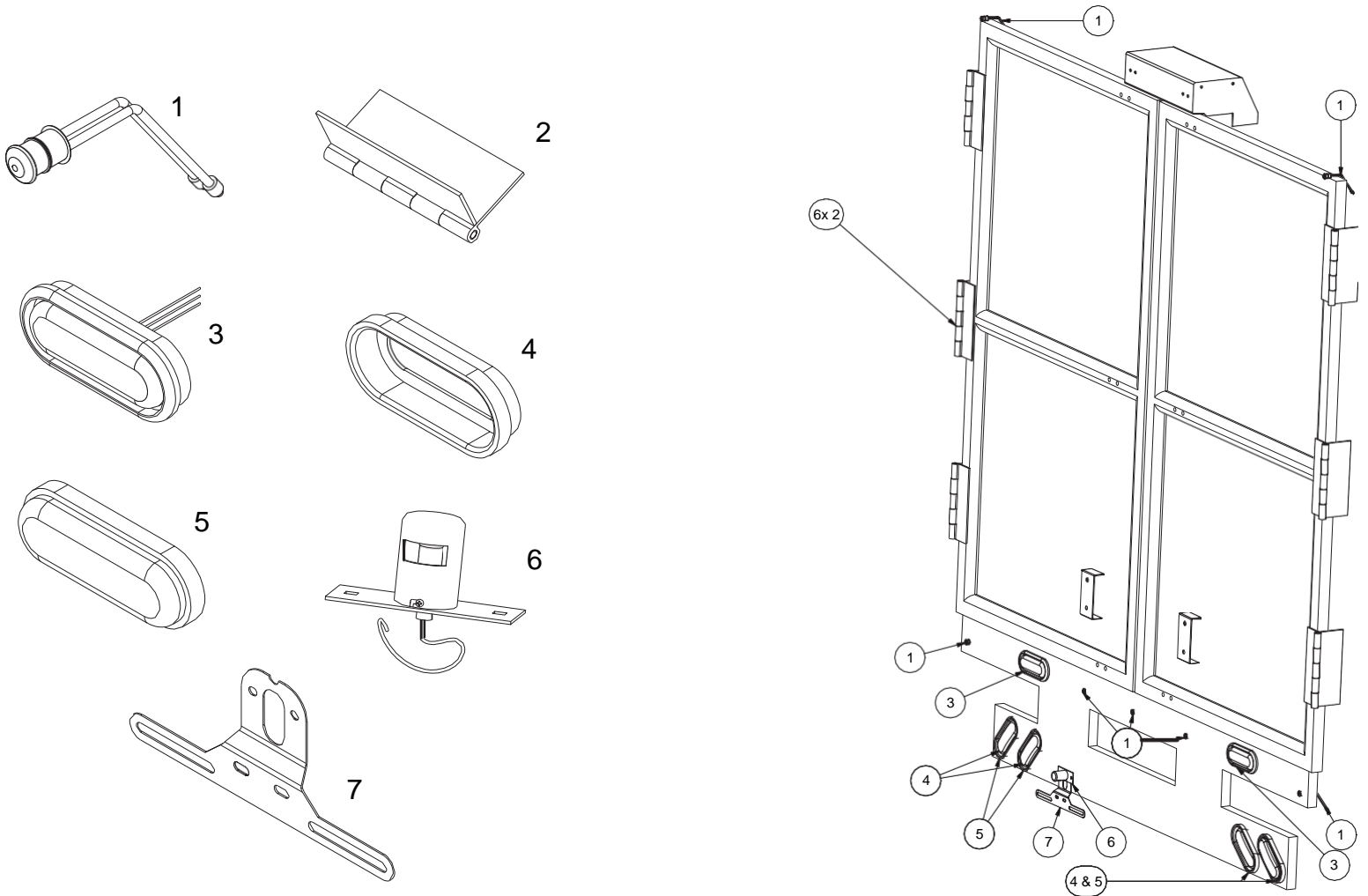

ITEM #	PART NUMBER	DESCRIPTION
1	STD.2201 STD.2202	LED Marker Light, Red-- rear of unit LED Marker Light, Yellow-- front of unit
2	SCL800.028	Door Hinge
3	STD.2213.A	LED Strobe Light with Flasher
4	STD.2414	LED Tail Light Assembly (after 01/05)
	94706	Plug Harness (after 01/05)
5	60700	Oval Grommet for tail light
6	LCT60.615B	License Plate Light
7	LCT600.010	License Plate Bracket

## 6.14 Rear Door Hardware

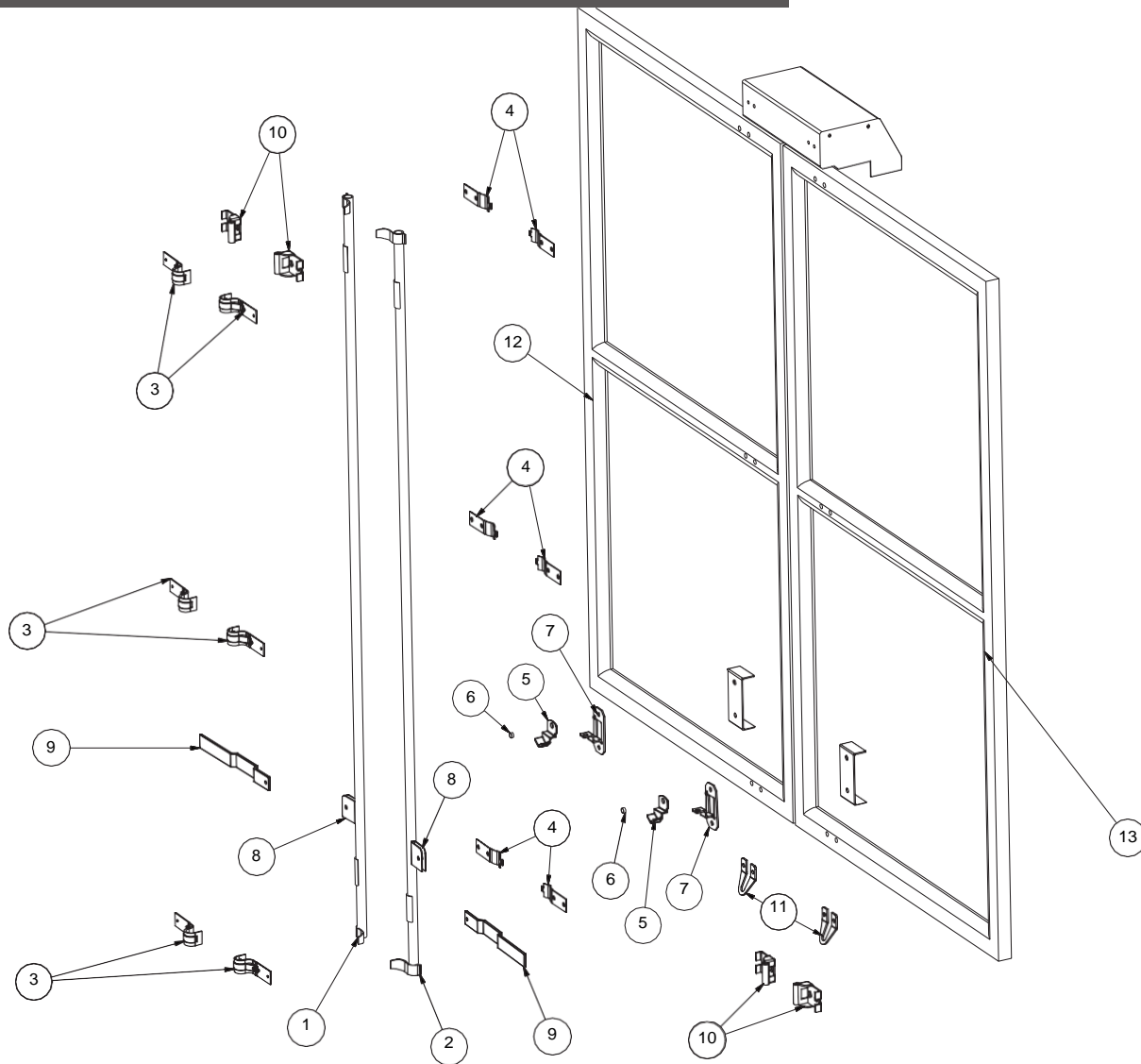

ITEM #	PART NO.	DESCRIPTION	ITEM #	PART NO.	DESCRIPTION
1	7502.14A	Door Rod, LH	11	7502.99	Lock Down Bracket
2	7502.14B	Door Rod, RH	12	SCL800.027B	Door, driver side
3	7502.2	Rod Bracket	13	SCL800.027A	Door, pass. side
4	7502.3	Rod Bracket Back	NS	SCL800.028	Hinge for Door
5	1969.7X	Seal Pin			
6	1969.39	Bushing			
7	1969.4X	Seal Plate			
8	1969.5	Handle Clip, welded on			
9	1969.6X	Handle			
10	7502.1	Keeper			

## 6.15 Intake Hose Group

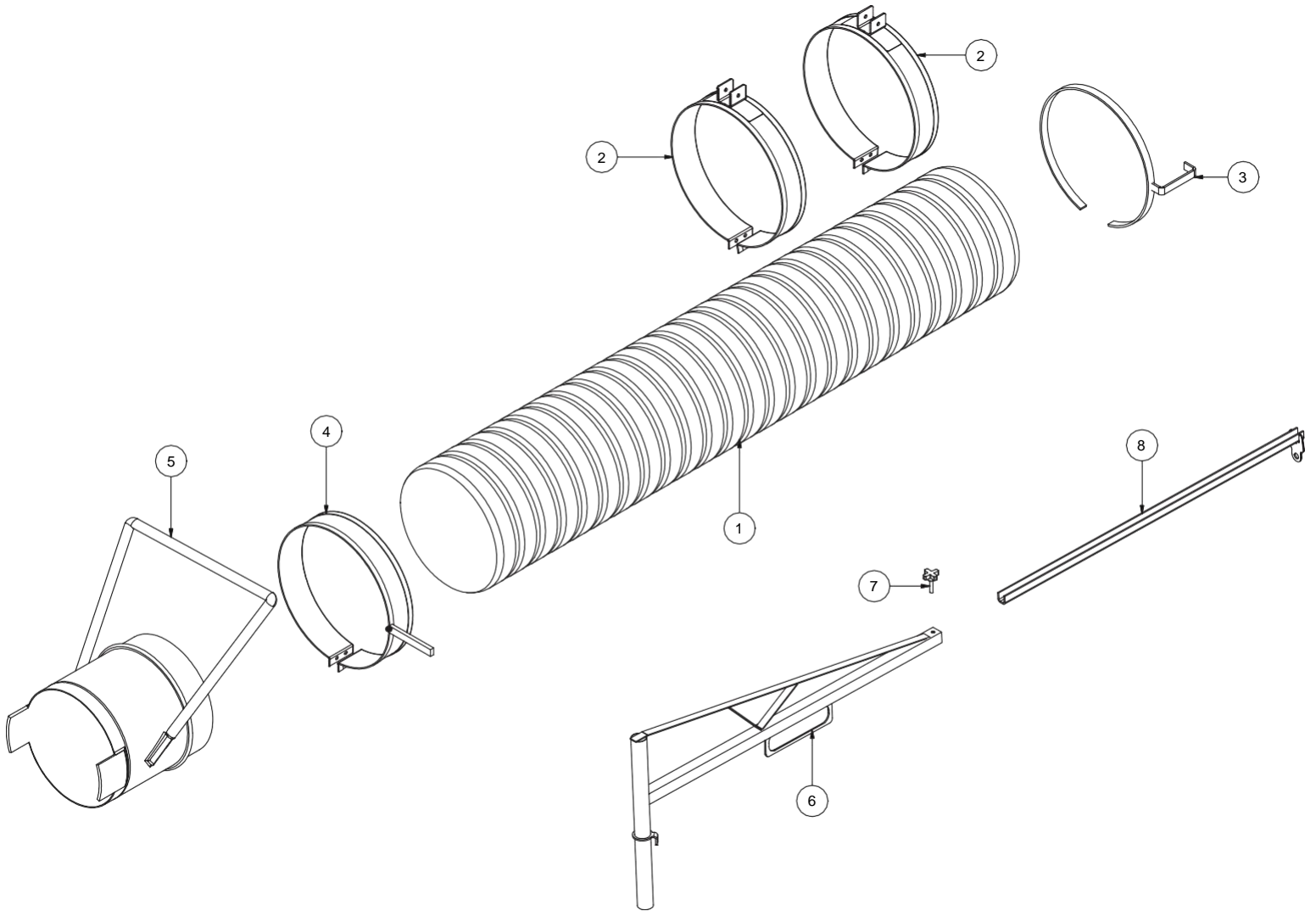

ITEM #	PART NO.	DESCRIPTION
1	STD.1602.12	Intake hose, 12' diameter
2	STD.1605.12	Support Band
3	65.1607	Hose Clamp With Limit Switch
4	65.1608	Hose Clamp, Nozzle
5	65.1600.12	Intake Nozzle
6	80.1601	Hose Boom
7	80.1605	Lockdown Knob
8	80.1601B	Boom Slide
NS	80.1602	Boom Latch Hook

## 6.16 Dump Hoist Group

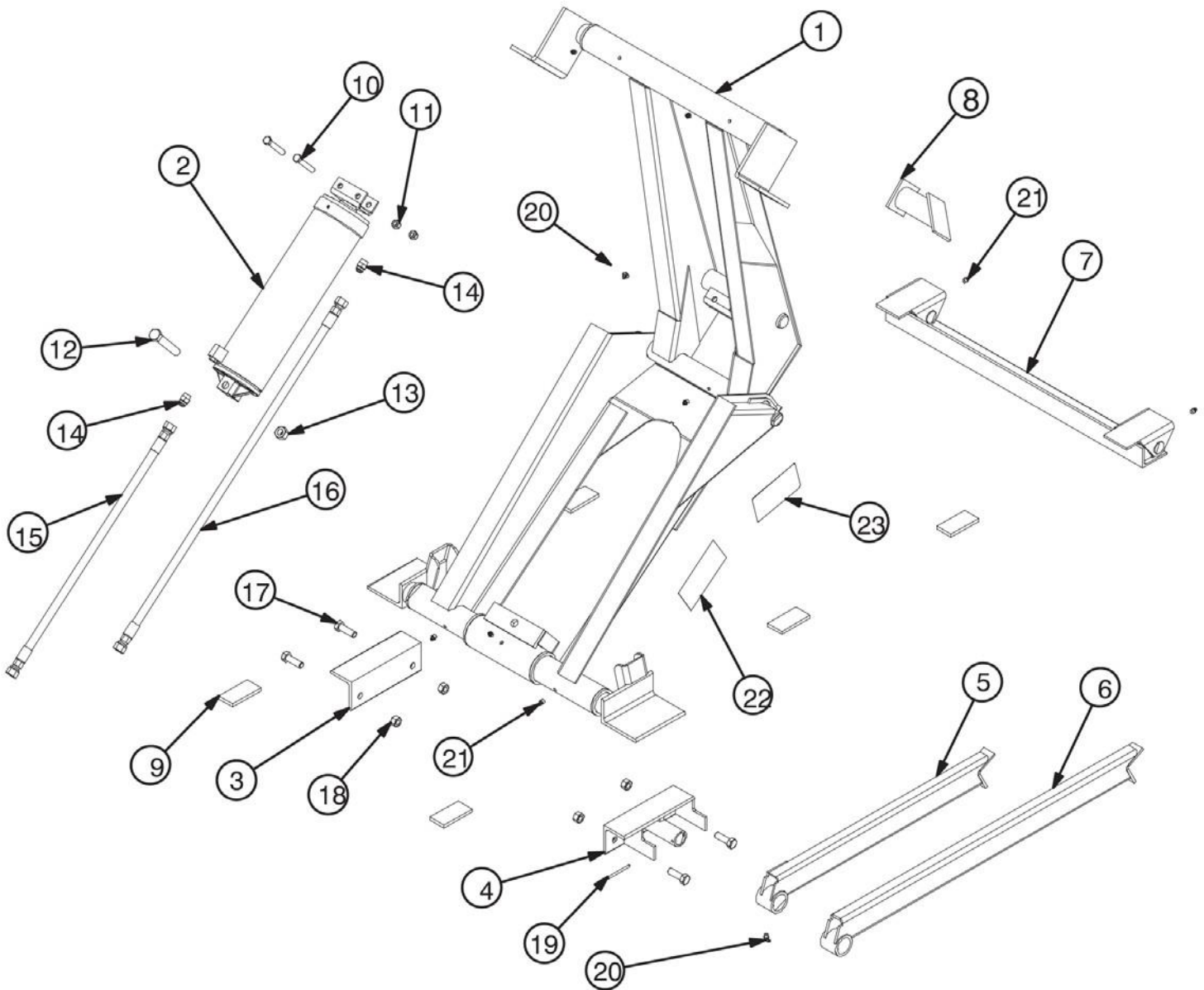

\*\* Need to get numbers off the hoist and cylinder before ordering \*\*

ITEM #	PART NO.	DESCRIPTION
1	1624895	Assembly Frame
2	1621572	Dump Cylinder
3		
4		
5	SCL800.015	Body Prop

# SAFETY PRECAUTIONS

## WARNING

Read and understand this entire manual before operating, maintaining or repairing the leaf vacuum.



# DO NOT RIDE, SIT OR STAND ON UNIT.

**RIDING ON UNIT  
COULD RESULT IN BODILY  
HARM OR FATAL INJURY  
USE EXTREME CAUTION WHEN  
UNIT IS IN USE, OR IN MOTION.**

If the decal above is missing or damaged call ODB immediately and we will send you a replacement free of charge. Never operate a unit with damaged or missing safety decals.

 **DANGER**

**DO NOT RIDE, SIT OR STAND ON UNIT**

 **DANGER**

**DO NOT MODIFY THE UNIT FOR RIDERS IN ANY WAY. SERIOUS INJURY OR DEATH MAY OCCUR**

ODB's leaf collectors are NEVER to be used to accommodate riders. If your unit has been modified to accommodate riders, remove these modifications immediately as this can result in serious injury or death.





**CAUTION**

**DO NOT ATTEMPT TO OPERATE  
OR REPAIR  
THE LEAF COLLECTOR WITHOUT FIRST  
READING AND UNDERSTANDING THIS  
MANUAL**

IF YOU HAVE ANY QUESTIONS CONCERNING THE  
INSTALLATION OR OPERATION OF THIS UNIT, PLEASE CALL  
ODB FOR ASSISTANCE BEFORE ATTEMPTING TO REPAIR OR  
OPERATE THE UNIT.

**IMPROPER USE OF ANY MACHINE CAN  
RESULT IN INJURY!**

**STUDY AND FOLLOW ALL SAFETY  
PRECAUTIONS BEFORE OPERATING OR  
REPAIRING UNIT**

THIS MANUAL IS AN INTEGRAL PART OF THE LEAF COLLECTOR AND SHOULD  
BE KEPT WITH THE UNIT WHEN IT IS SOLD.