

# **DCL500SM**

## **Automated Self-Contained Debris Collector**



**Owner's Manual  
Safety Manual  
Pre-Operating Manual  
Operating Manual  
Maintenance Manual  
Service Manual  
Parts Catalog**

**2020 Edition, Rev 002**

ODB Company  
5118 Glen Alden Drive

Richmond, VA 23231  
800-446-9823

**⚠ CAUTION**

**DO NOT ATTEMPT TO OPERATE  
OR REPAIR  
THE DEBRIS COLLECTOR WITHOUT  
FIRST READING AND UNDERSTANDING  
THIS MANUAL**

IF YOU HAVE ANY QUESTIONS CONCERNING THE  
INSTALLATION OR OPERATION OF THIS UNIT,  
PLEASE CALL **ODB** FOR ASSISTANCE BEFORE  
ATTEMPTING TO REPAIR OR OPERATE THE UNIT.

**IMPROPER USE OF ANY MACHINE  
CAN RESULT IN SERIOUS INJURY!**

**STUDY AND FOLLOW ALL SAFETY  
PRECAUTIONS BEFORE OPERATING  
OR REPAIRING UNIT**

THIS MANUAL is an INTEGRAL PART of the DEBRIS COLLECTOR  
and SHOULD BE KEPT WITH the UNIT WHEN IT IS SOLD.

**ODB COMPANY**



**ODB Company**

**DCL500SM**

# Safety Section

## WARNING

Read and understand this entire manual before operating, maintaining or repairing the leaf vacuum.



**DO NOT RIDE, SIT OR STAND  
ON UNIT.**

**RIDING ON UNIT  
COULD RESULT IN BODILY  
HARM OR FATAL INJURY  
USE EXTREME CAUTION WHEN  
UNIT IS IN USE, OR IN MOTION.**

If the decal above is missing or damaged call ODB immediately and we will send you a replacement free of charge. Never operate a unit with damaged or missing safety decals.

** DANGER**

**DO NOT RIDE, SIT OR STAND ON UNIT**

** DANGER**

**DO NOT MODIFY THE UNIT FOR RIDERS IN ANY  
WAY. SERIOUS INJURY OR DEATH MAY OCCUR**

ODB's debris collectors are NEVER to be used to accommodate riders. If your unit has been modified to accommodate riders, remove these modifications immediately as this can result in serious injury or death.

Municipal Products  
Since 1910



Municipal Products  
Since 1910

5118 Glen Alden Drive  
Richmond, VA 23231  
**800-446-9823**  
**www.odbco.com or**  
**www.leafcollector.com**

## THANK YOU

Thank you and Congratulations on your purchase of your ODB Leaf Collector. Your ODB leaf collector has been carefully designed and manufactured to give you a maximum amount of dependability and years of trouble-free operation. Take comfort in the fact the ODB has been manufacturing municipal products since 1910 and takes pride in our product's quality and our customer service.

Please take the time to thoroughly read this manual, as well as the engine manual, in its entirety before operating, maintaining, servicing or repairing your leaf collector. Please thoroughly review and follow all the safety procedures located in this manual.

Whenever you need replacement parts, service information or any question regarding your ODB product please feel free to contact us at 800-446-9823 or [www.odbco.com](http://www.odbco.com).

Please record the following information for future reference:

Model No.:	_____
Serial No.:	_____
Vin No:	_____
Engine Serial No.:	_____
Date of Purchase:	_____

# Table of Contents

## Contents

DCL500SM, Rev 001 .....	1
Automated Self-Contained Debris Collector.....	1
1.0 General Safety .....	9
1.1 Safety Symbol Definitions .....	11
1.2 Training:.....	14
1.3 Safety Decals .....	15
1.4 Serial Number Location.....	19
2.0 Pre-Operating Section .....	18
2.1 Safe Operations .....	19
2.2 Preparation for Operation.....	21
2.2 Pre-Transport Checks .....	22
2.3 Personal Protective Equipment and Clothing .....	23
2.4 Work Site Preparation .....	24
3.0 Operating Section.....	25
3.1 Basic Operations - Engine Control .....	26
3.2 Basic Operations - Boom Control .....	27
3.3 Basic Operation – Dumping the body .....	28
4.0 Maintenance Section .....	29
4.1 Maintenance Overview.....	30
4.2 Maintenance and Lubrication .....	31
4.3 Lubrication .....	32
4.4 Preventative Maintenance.....	35
4.5 Torque Values.....	40
4.6 Kraft Fluid Drive Maintenance (Optional).....	41
5.0 Service Section.....	43
5.1 Removing Blower Housing Face .....	44
5.2 Replacing the Drive Bearings .....	45
5.2 Replacing the Drive Bearings Cont. ....	46
5.3 Impeller Installation and Removal .....	48
5.4 Replacing the Blower Housing Liners.....	50
5.5 Hydraulic Schematic .....	52
5.6 Electrical Schematic.....	53
5.6 Electrical Schematic.....	54
PARTS BREAKDOWN SECTIONS.....	60
6.0 Engine Group .....	61
6.1 Engine Group .....	62
6.2 Engine Mount Group .....	67
6.3 Electronic Throttle .....	68

# Table of Contents

6.4 Battery Group.....	69
7.0 Hydraulic/Electrical Group.....	70
7.1 Hydraulic Group.....	71
7.2 Electrical Group.....	75
8.0 Skid Group.....	91
<b>8.1 Blower Housing Group.....</b>	<b>94</b>
8.2 Skid Group.....	94
<b>8.3 Pedestal Group.....</b>	<b>96</b>
9.1 Fuel Tank Group.....	98
9.2 Box Group.....	97
9.3 Chassis Group.....	98
9.4 Light and Reflector Group.....	99
9.5 Backup Camera.....	100
10.0 Hose Boom Group.....	101
10.1 Boom Group.....	109
10.2 Cab Controls.....	110
10.3 Auburn Gear Drive.....	111

# Revision Table

Date	Revision	Description
9/26/20	000	Manual created
11/3/20	001	Lubrication locations, hydraulic oil spec, maintenance instructions, light and reflector group
11/9/20	002	Updated Boom Control
5/25/21	004	Gen.2 skid,hyd.
5/19/21	006	Updated part # of Inst. Panel to 2018XZ

# Safety Section

## **WARNING**

Read and understand this entire manual before operating, maintaining or repairing the debris vacuum.

## 1.0 GENERAL SAFETY

# 1.0 General Safety



# Safety Section

## **⚠ WARNING**

Read and understand this entire manual before operating, maintaining or repairing the debris vacuum.



**DO NOT RIDE, SIT OR STAND  
ON UNIT.**

**RIDING ON UNIT  
COULD RESULT IN BODILY  
HARM OR FATAL INJURY  
USE EXTREME CAUTION WHEN  
UNIT IS IN USE, OR IN MOTION.**

If the decal above is missing or damaged call ODB immediately and we will send you a replacement free of charge. Never operate a unit with damaged or missing safety decals.

**⚠ DANGER**

**DO NOT RIDE, SIT OR STAND ON UNIT**

**⚠ DANGER**

**DO NOT MODIFY THE UNIT FOR RIDERS IN ANY  
WAY. SERIOUS INJURY OR DEATH MAY OCCUR**

ODB's leaf collectors are NEVER to be used to accommodate riders. If your unit has been modified to accommodate riders, remove these modifications immediately as this can result in serious injury or death.

# Safety Section





## **WARNING**

Read and understand this entire manual before operating, maintaining or repairing the debris vacuum.

## 1.1 Safety Symbol Definitions

This manual provides the owners/operator with procedures for safe operation, maintenance and repair of your leaf collector. As with any machine, there are hazards associated with their operation. For this reason, safety is emphasized throughout this manual. To highlight specific safety information the following safety definitions are provided to assist the reader.

The purpose of safety symbols is to attract your attention to possible dangers. The safety symbols, and their explanations, deserve your careful attention and understanding. The safety warnings do not by themselves eliminate any danger. The instructions or warnings they give are not substitutes for proper accident prevention measures.

SYMBOL	MEANING
	<b>SAFETY ALERT SYMBOL:</b> Indicates danger, warning or caution. attention is required in order to avoid serious personal injury. May be used in conjunction with other symbols or pictographs.
	Disregarding this safety warning <b><u>WILL</u></b> result in serious equipment damage, injury or possible death.
	Disregarding this safety warning <b><u>CAN</u></b> result in serious equipment damage, injury or possible death.
	Disregarding this safety warning <b><u>MAY</u></b> result in minor or moderate injury or property damage.

# Safety Section

## **WARNING**

Read and understand this entire manual before operating, maintaining or repairing the debris vacuum.

### 1.1 Do's and Do Not's:

This section contains some general safety precautions to do and not to do. This is not an all-inclusive list and it is the responsibility of the operator to have proper training and use common sense in work situations.

## **WARNING**

### **DO NOT:**

1. **DO NOT** operate, maintain or repair this unit without having fully read and understood ALL the aspects of this manual.
2. **DO NOT** ride, sit or stand on unit at any time.
3. **DO NOT** modify the leaf vacuum for any reasons to allow for riders.
4. **DO NOT** operate the unit in a state of disrepair.
5. **DO NOT** operate the unit with ANY guards or safety devices broken, missing, or inoperable.
6. **DO NOT** operate the unit without wearing proper safety equipment.
7. **DO NOT** operate this unit while under the influence of any alcohol or medication.
8. **DO NOT** operate this unit if you have a record of mental instability or dizziness which could result in injury to yourself or others.
9. **DO NOT** operate this unit if you are under 18 years of age.
10. **DO NOT** operate this unit without fully inspecting the unit for any damage or leakage.
11. **DO NOT** operate if the unit has any excessive vibration.
12. **DO NOT** operate unit with the inspection door limit switch damaged or missing.
13. **DO NOT** operate unit unless it is properly connected to a leaf collection box.
14. **DO NOT** operate unit unless it is properly attached to the tow vehicle.
15. **DO NOT** tow unit without using all the safety chains.
16. **DO NOT** tow unit with a damaged tongue.
17. **DO NOT** fill fuel tank with engine running. Allow engine to cool for 5 minutes before refueling.
18. **DO NOT** operate unit if fuel is spilled or with fuel cap off.
19. **DO NOT** smoke or weld near the unit.
20. **DO NOT** run engine in an enclosed area.
21. **DO NOT** place hands or feet near moving or rotating parts.

# Safety Section

## WARNING

### Do Not, continued;

22. **DO NOT** operate engine with an accumulation of grass, leaves or other debris on the engine.
23. **DO NOT** run engine with air cleaner removed.
24. **DO NOT** leave leaf machine unattended while in operation.
25. **DO NOT** park machine on steep grade or slope.
26. **DO NOT** vacuum a leaf pile without looking for foreign objects such as metal, glass, plastic or large pieces of wood.

## WARNING

### Do's:

1. **DO** completely read and understand the owner's manual before operating, maintaining or repairing the leaf collector.
2. **DO** follow engine and PTO manufacturer operating and maintenance instructions.
3. **DO** check fuel lines and fittings frequently for cracks or leaks. Replace if necessary.
4. **DO** completely inspect the unit before leaving the service garage.
5. **DO** check the tow tongue each day for cracks.
6. **DO** inspect and be attentive to what is being vacuumed.
7. **DO** check the impeller, liners and blower housing for cracks or holes daily.
8. **DO** wear proper safety equipment as described in this manual.
9. **DO** watch for pedestrians, animals and other foreign material when vacuuming leaves.
10. **DO** replace any worn or missing safety stickers immediately.

## WARNING

Battery posts, terminals and related accessories contain lead and lead compounds, chemicals known to the state of California to cause cancer and birth defects or other reproductive harm. Wash Hands after handling

## WARNING

Engine Exhaust, some its constituents and certain vehicle components contain or emit chemicals known to the state of California to cause cancer and birth defects or other reproductive harm.

## 1.2 Training:

### **⚠ WARNING**

**Improper use of the ODB debris collector CAN result in severe personal injury or death. All personnel using this debris vacuum must be trained and qualified with all the operations, maintenance, repair and safety procedures defined in this manual.**

The warnings and procedures regarding safety in this manual are to be used as a guideline only. It is impossible to cover all the events that could happen in the vacuuming process. For this reason, it is vital that the owner accept the responsibility to implement a training program that will provide every operator or mechanic the basic skills and knowledge to make good judgement in all situations.

This training program must include the entire scope of hazards, precautions and government regulations encountered in the vacuuming process. The program should stress the need for regularly scheduled preventive maintenance and detailed equipment safety checks.

It is strongly recommended that all training programs be documented to ensure all operators and mechanics receive initial training on not just the operation but the safety features of the leaf collector.

# Safety Section

## 1.3 Safety Decals

Read and Follow all Safety Sticker Warnings-- Replace all damaged or missing stickers immediately.



### 1134XZ DECAL PACKAGE

1	Warning – Rotating Parts	15	Caution – Idle engine before shutdown
2	Caution – Clearance Height	16	Use gas only
3	Do not over lubricate bearings	17	Ultra low sulfur diesel fuel only
4	Danger – Do not go under raised body	18	Warning – Do Not Open Cover
5	Danger – Explosion hazard	19	Warning – PPE Required
6	Danger – Hoist Controls	20	Warning – Do not open doors
7	Danger – Do not ride or sit on unit	21	Use diesel only
8	Ultra low sulfur diesel fuel only	22	Warning – Do not open doors (Spanish)
9	Clean hopper screens daily	23	Warning - Flammable
10	Warning – Check impeller and liners daily	24	Caution – Body brace
11	Warning – Read manual before operating	25	Warning – Operation of Body Prop
12	Use diesel only	26	Caution – Unload Body
13	Caution – Read manual before repairing	27	Caution – Unload Body
14	Caution – Idle engine before shutdown		

# Safety Section

1

**⚠ WARNING**  
**ROTATING PARTS**  
 1. BEFORE OPERATING READ OPERATORS MANUAL FOR OPERATING AND SAFETY INSTRUCTIONS.  
 2. DO NOT OPERATE WITH ANY GUARDS OR COMPONENT PARTS REMOVED FROM UNIT.  
 3. BEFORE MAKING AND ADJUSTMENTS OR REPAIRS STOP ENGINE AND REMOVE SPARK PLUG WIRE.  
 4. WHILE IN OPERATION KEEP ALL PARTS OF BODY AWAY FROM INTAKE AND EXHAUST SECTIONS.  
 5. WHEN OPERATING MACHINE KEEP PEOPLE AND PETS A SAFE DISTANCE AWAY.

RPODB-10

**⚠ ADVERTENCIA**  
**PIEZAS EN ROTACION**  
 1. ANTES DE USAR LEA LAS INSTRUCCIONES DE OPERACION Y SEGURIDAD EN EL MANUAL DEL OPERADOR.  
 2. NO OPERE SI CUALQUIER PROTECTOR O COMPONENTE FUE RETIRADO DE LA UNIDAD.  
 3. ANTES DE HACER CUALQUIER AJUSTE O REPARACION, DETIENGA EL MOTOR Y RETIRE EL CABLE DE LA BUJIA.  
 4. MIENTRAS ESTA EN OPERACION, MANTENGA ALEJADAS TODAS LAS PARTES DEL CUERPO DE LAS SECCIONES DE ADMISION Y ESCAPE.  
 5. CUANDO LA MAQUINA ESTE EN FUNCIONAMIENTO, MANTENGA A LAS PERSONAS Y MASCOTAS A UNA DISTANCIA SEGURA.

RPODB-10

5

**⚠ DANGER**  
**EXPLOSION HAZARD**  
 DO NOT CUT, BURN OR WELD WITHOUT FIRST REMOVING OR COMPLETELY PURGING THE FUEL TANK

CONSULT OWNERS MANUAL RPODB-6

**⚠ CAUTION**  
**CLEARANCE**  
**VEHICLE HEIGHT**

1

**DO NOT OVER-LUBRICATE**  
 BEARING SHOULD BE LUBRICATED EVERY 10-15 HOURS OF OPERATION WITH .2 OZ. (ABOUT 2 STROKES OF AVERAGE GREASE GUN) OF APPROVED LUBRICANT. USE THE ENGINE HOUR METER AS A REFERENCE.

*SEE YOUR OWNER'S MANUAL*

RPODB-29

**⚠ PELIGRO**  
**DE EXPLOSIÓN**  
 NO CORTE, QUEME O SOLDE SIN ANTES ELIMINAR O PURGAR POR COMPLETO EL TANQUE DE COMBUSTIBLE

CONSULTE EL MANUAL DE USUARIO RPODB-6

2

1 2 3 4 5  
 6 7 8 9 0

3

6

**⚠ DANGER**  
 • DO NOT GO UNDER RAISED BODY IT MAY DROP AND KILL YOU  
 • OPERATE HOIST CONTROLS ONLY FROM INSIDE TRUCK CAB



401577

4

**⚠ DANGER**  
 DO NOT GO UNDER RAISED BODY IT MAY DROP AND KILL YOU

- OPERATE HOIST CONTROLS ONLY FROM FRONT OF UNIT



**⚠ PELIGRO**  
 • NO SE UBIQUE DEBAJO DEL CUERPO ELEVADO DE LA UNIDAD;  
 • PODRIA DESCENDER Y OCCASIONARLE LA MUERTE OPERE LOS CONTROLES DEL MALACATE UNICAMENTE DESDE LA PARTE FRONTAL DE LA UNIDAD



7

**⚠ DANGER**  
 DO NOT RIDE, SIT OR STAND ON UNIT.  
 RIDING ON UNIT COULD RESULT IN BODILY HARM OR FATAL INJURY  
 USE EXTREME CAUTION WHEN UNIT IS IN USE, OR IN MOTION.

RPODB-2

**8**  
**ULTRA LOW SULFUR DIESEL FUEL ONLY**

**9**  
**CLEAN HOPPER SCREENS EVERY 8-10 HRS**

**⚠ PELIGRO**  
 NO SE SUBA, SIENDE O PARE SOBRE LA UNIDAD.  
 SUBIRSE A LA UNIDAD PUEDE RESULTAR EN LESIONES GRAVE O LETALES. TENGA EXTREMA PRECAUCION CUANDO ESTA UNIDAD ESTE EN USO O MOVIMIENTO.

RPODB-2

**10**  
**⚠ WARNING**  
**CHECK IMPELLER AND BLOWER HOUSING LINERS FOR WEAR DAILY**  
 WORN IMPELLER OR LINERS COULD RESULT IN EQUIPMENT DAMAGE AND SERIOUS BODILY INJURY

RPODB-14

**⚠ ADVERTENCIA**  
 REVISE DIARIAMENTE EL DESGASTE DE LOS REVESTIMIENTOS DE LA CUBIERTA DEL SOPLADOR E IMPULSOR.  
 EL IMPULSOR O LOS REVESTIMIENTOS DESGASTADOS PODRIAN RESULTAR EN DANOS AL EQUIPO Y LESIONES CORPORALES GRAVES

RPODB-14



# Safety Section

11

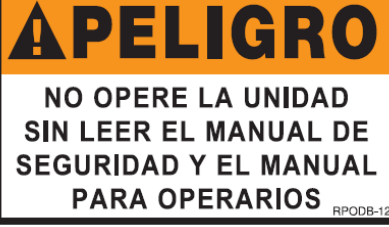

12



13

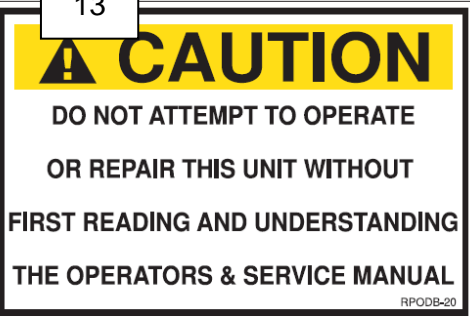

14



17



14

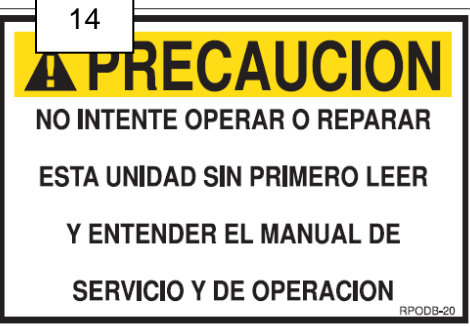

15



19



16



18





# Safety Section

20

**WARNING**  
DO NOT OPEN  
DOORS WHILE UNIT  
IS IN OPERATION

RP00B-17

E110052730

**USE  
DIESEL  
ONLY**

21

**PELIGRO**  
NO ABRA LAS PUERTAS  
MIENTRAS LA UNIDAD  
ESTA EN OPERACION

RP00B-17

22

23

**ADVERTENCIA  
INFLAMABLE**



RP00B-9

**WARNING  
FLAMMABLE**



RP00B-9

24

**CAUTION**

- BODY MUST BE BRACED BEFORE SERVICING HOIST OR WORKING IN AREA WITH BODY IN RAISED POSITION.
- LUBRICATE HOIST GREASE FITTINGS OFTEN - AT LEAST EACH TIME TRUCK IS SERVICED.
- TRUCK MUST BE LEVEL FOR DUMPING.
- DO NOT OVERLOAD.

CRYSTEEL MFG., INC. 400543

25

**OPERATION OF BODY PROP**

- Raise body to full height and shut off all power.
- Raise prop to upright position.
- Lower body slowly until body bracket contacts prop.
- DO NOT POWER HOIST DOWN.

400719

26

**CAUTION**  
UNLOAD BODY BEFORE  
USING BODY PROP.

DCL500SM14

27

**CAUTION**  
UNLOAD BODY BEFORE  
USING BODY PROP.

**CAUTION**

- BODY MUST BE BRACED BEFORE SERVICING HOIST OR WORKING IN AREA WITH BODY IN RAISED POSITION.
- LUBRICATE HOIST GREASE FITTINGS OFTEN - AT LEAST EACH TIME TRUCK IS SERVICED.
- TRUCK MUST BE LEVEL FOR DUMPING.
- DO NOT OVERLOAD.

**OPERATION OF BODY PROP**

- Raise body to full height and shut off all power.
- Raise prop to upright position.
- Lower body slowly until body bracket contacts prop.
- DO NOT POWER HOIST DOWN.

400719

26

# Safety Section

## 1.4 Serial Number Location

### ⚠ WARNING

Thoroughly read and understand the safety and pre-operating sections of this manual before starting the engine.



### ⚠ WARNING

Make sure each operator knows and understands the load ratings of the towed vehicle and that he/she is qualified to tow the vehicle.

The serial number tag is located on the chassis on boom side of the unit. It should be in front of the fenders going toward the front of the unit. (See figure 1.5a).

figure 1.5a

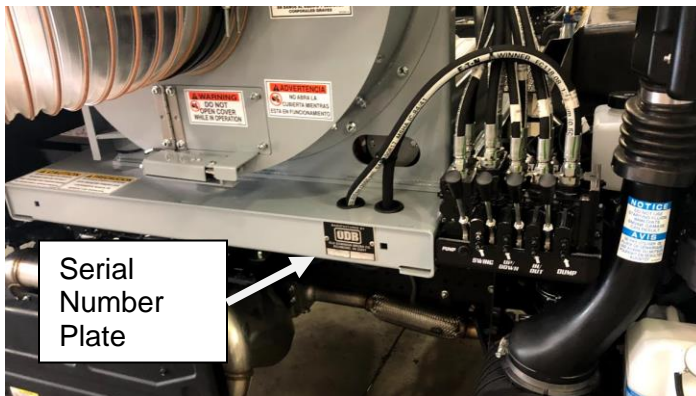

# 2.0 PRE-OPERATING SECTION

## **⚠ WARNING**

Read and understand this entire manual before operating, maintaining or repairing the debris vacuum.

## 2.0 Pre-Operating Section

# 2.0 Pre-Operating Section

## 2.1 Safe Operations

### **⚠ WARNING**

ALL personnel using, maintaining or servicing this unit must be trained in all safety procedures outlined in this manual. Improper or careless use of this equipment CAN result in personal injury or death.

Operations shall be restricted to:

1. Properly trained, qualified and experienced operators and/or qualified and experienced maintenance and test personnel.
2. Trainees under the direct supervision of qualified and experience personnel.
3. Qualified and experienced maintenance and service personnel.

Operators who qualify to operate this equipment under the above restrictions shall also comply with the following physical requirements:

1. Have good vision and the ability to read and understand this manual as well as all safety and operational decals on the equipment.
2. Be capable of hearing, with or without a hearing aid, at a level needed to safely operate this equipment.
3. A record of mental stability with no history of epileptic seizures, dizziness, or any other disability that may result in injury to himself or others.

If any of these requirements are not satisfied at any time, the person failing to meet these requirements **MUST NOT OPERATE THIS EQUIPMENT.**

## 2.1-Safe Operations (continued):

### Additional Requirements:

1. Each operator must demonstrate competence to understand all safety decals, operator's manuals, safety codes, applicable government regulations, and all other information applicable to the safe and proper operation of the leaf vacuum.
2. Each operator must demonstrate the ability to recognize an emergency that may arise during vacuuming operations and the knowledge and procedures to implement corrective action.
3. Each operator must demonstrate or provide evidence of qualification and experience prior to operating the leaf vacuum.
4. Each operator must be able to recognize existing or potential problems regarding the mechanical integrity of the leaf vacuum and report any maintenance requirements to the supervisor in charge.
5. Each operator must wear the proper personal clothing and safety gear. (Refer to SAFETY PRECAUTIONS Section 5.4)
6. Operators must not be physically or mentally fatigued.
7. Operators must not be under the direct or indirect influence of alcohol and/or drugs. This includes prescription drugs that could cause drowsiness, dizziness, or any other condition that would impair their ability to operate or use this equipment in a safe manner.

# Pre-Operating Section

## 2.2 Preparation for Operation

### ⚠ CAUTION

Before your debris vacuum is put into operation it is very important to read and follow the procedures outlined in the engine owner's manual. (EOM).

For specific information regarding the following checks please refer to the "Maintenance" section of this manual and the engine owner's manual.

### ⚠ WARNING

**DISENGAGE** the clutch and remove the negative battery cable before performing the following checks.

### ⚠ WARNING

**NEVER** place any part of the body under or behind guards or any other area in which you cannot see.

#### IMPORTANT CHECKS:

**NOTE:** The following checks contained in the next three sections should be performed prior to leaving the storage area.

1. Check engine fuel, coolant and oil levels. (see EOM)
2. Check engine air filter
3. Check all bolts and nuts to ensure they are tight.
4. Check all controls for free and proper operation.
5. Check main drive belt (if equipped) for proper adjustment.
6. Inspect the fan blades to ensure that they are not bent, deformed, fatigued or cracked. Replace fan if any damage is present.
7. Inspect the intake hose flange to make sure it is connected correctly to the blower housing.
8. Inspect the leaf vacuum frame and structure for any bent, broken, cracked, missing or loose parts.
9. Check all guards to ensure they are undamaged, in place and properly secured.
10. All decals must be in place and legible prior to operating the leaf vacuum. See the decal section for decal replacement.

## 2.2 Pre-Transport Checks

### **⚠ WARNING**

Failure to verify the road worthiness of the debris vacuum and the truck and verify all equipment is properly stowed, may cause serious injury or death to yourself or others.

Do not tow the debris vacuum unless all important checks listed below are completed.

### **IMPORTANT CHECKS:**

1. The hose boom is properly secured.
  - a. Be sure nozzle is in the cradle securely.
2. The unit's lighting is operating properly.
3. Check the general condition of the tires, tire pressure and ensure that all lug nuts are securely fastened.
4. Visual examination of the leaf vacuum frame, suspension and structure to determine if all components are correctly positioned and secured for travel.
5. Check the intake hose boom to verify that it is securely fastened to the leaf vacuum and cannot swing free.
6. Verify there are no loose tools or materials on the unit, inside the intake and exhaust hoses, or inside the engine sheet metal.
7. Check all cones, wheel-chocks, signs or other support tools and materials to ensure proper stowage.
8. Verify the driver of the unit is qualified to tow the type and weight of the unit.

# Pre-Operating Section

## 2.3 Personal Protective Equipment and Clothing

### **WARNING**

**Always** wear proper safety equipment as outlined below, not wearing such equipment **CAN** result in serious personal injury or possible death.

### IMPORTANT CHECKS:

Anyone operating the leaf vacuum equipment **MUST** wear appropriate protective equipment and clothing to protect them from injury during operations.

### **PROTECTIVE EQUIPMENT:**

8. **Head Protection:** Hard hats without under-chin strapping.
9. **Eye Protection:** Wraparound goggle type eye protection held in place with an elastic band around the head or a hard hat mounted face shield, which provides full protection of the face.
10. **Eye protection** must meet ANSI Z87.1 standard.
11. **Hearing Protection:** plug type or “muff type” ear protection should be worn always while operating the unit.
12. **Breathing Protection:** Paper filter type dust masks should be worn to protect from dirt and dust particles during the vacuuming process.
13. **Reflective Vests:** Highly visible vests should be worn so motorists can see the operator in all weather and lighting conditions.
14. **Work Gloves:** Gloves should be worn to protect the hands and wrists from debris.
15. **Steel Toed Boots:** should be worn to protect the feet.

### **DANGER**

Work clothes **MUST** be close fitting, but not restrictive of movement, without any loose parts that could be entangled in any parts of the debris vacuum. This includes items such as jewelry, chains and backpacks.



## 2.4 Work Site Preparation

### **⚠ WARNING**

**Never place any part of the body under or behind guards or any other visually obscured area.**

**Making sure the leaves are clear of possible dangerous material is critical to safe vacuuming. Vacuuming up metal, glass, rocks or other dangerous material CAN cause serious damage to the equipment or personal injury.**

**The following guidelines must be followed to ensure safety.**

1. An inspection of the leaves to be vacuumed must be done prior to the vacuuming process. We realize that it is impossible to completely inspect every inch of leaves being vacuumed, but it is imperative that all leaves be inspected for obvious dangerous material before vacuuming.
2. The operator should never be in the line of traffic, the operator should work on the shoulder whenever possible.
3. The operators should place cones or other barriers to provide adequate warnings to vehicles and pedestrians that vacuuming is in progress.
4. Strobe lights on the leaf vacuum and on the tow, vehicle should always be on for high visibility.
5. Confirm that all operators are wearing proper clothes and personal protective equipment.
6. Restrict all personnel, except the operator from the area near the leaf vacuum. **DO NOT** allow pedestrians, children or animals near the work area.
7. Make sure that the exhaust hose (if equipped) fits properly into the box container so that all debris is blown into the box container.

# 3.0 OPERATING SECTION

## **⚠ WARNING**

Read and understand this entire manual before operating, maintaining or repairing the debris vacuum.

## 3.0 Operating Section

# Operating Section

## 3.1 Basic Operations - Engine Control



### 1.) Ignition Switch:

Used to power the accessories and start the unit. Unit will not start without Murphy switch depressed.

ACCESSORIES - first position

STARTER ENGAGE - second position (springs return to first position)

### 2.) Murphy Switch (Safety Shutoff):

This switch overrides the low oil pressure and high temperature cutoff control. This switch must be depressed before the starter engages. After the engine starts, wait for oil pressure to rise before releasing the button.

### 3.) Throttle Control (Aux engine):

Forward position (Eco Mode): High speed when joystick deadman is depressed. Middle Position: Low speed. Rear Position: High speed

### 4.) Combination Tachometer / Hour Meter:

This gauge indicates the engine RPM. The sender is located on the tachometer. The hour meter is digital and indicates the accumulated hours of the engine. This should be used to schedule maintenance.

### 5.) Volt Meter:

The gauge shows the status of the engine charging system. When the charging system is operating properly it should read approximately 14 volts. If the gauge reads below 13 volts, the alternator is not charging the battery and the system should be checked by a qualified technician.

### 6.) Oil Pressure Gauge:

Confirms and indicates the presense and pressure of engine oil. If the gauge reads low, it should be checked by a qualified technician.

# Operating Section

## 3.2 Basic Operations - Boom Control

### **⚠ WARNING**

**Always** make sure that operating area of boom is clear before operating the boom, failure to do so **CAN** result in serious personal injury or possible death.

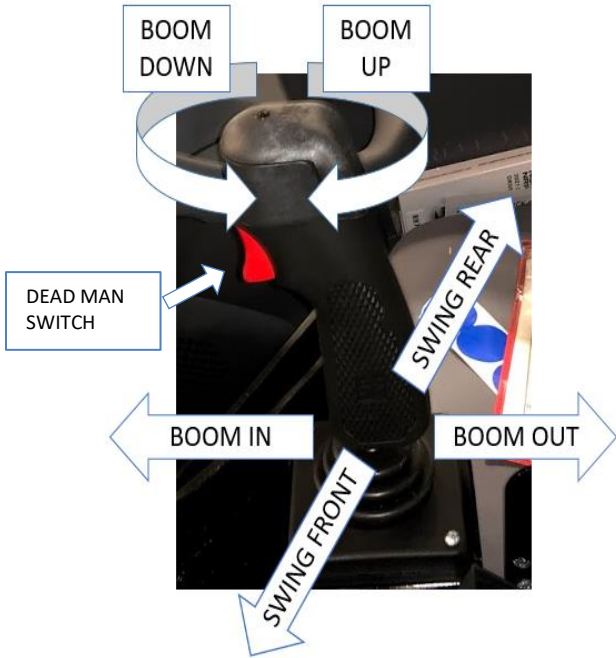

### Boom operation

- 1.) Start auxiliary engine:
  - a. Hold down murphy switch (maintain)
  - b. Use the other hand to turn the ignition key
  - c. Once the engine has started, release murphy switch

The boom is powered from the auxiliary hydraulic pump mounted on the motor.

- 2.) Ensure that the safety chain on the boom nozzle is removed
- 3.) Ensure that the boom's operating area is clear.
- 4.) Depress joystick dead man , and manipulate boom in area of leaves or debris
- 5.) Store boom in cradle when complete
- 6.) Always re-latch boom nozzle chain after leaf or debris collection is complete.

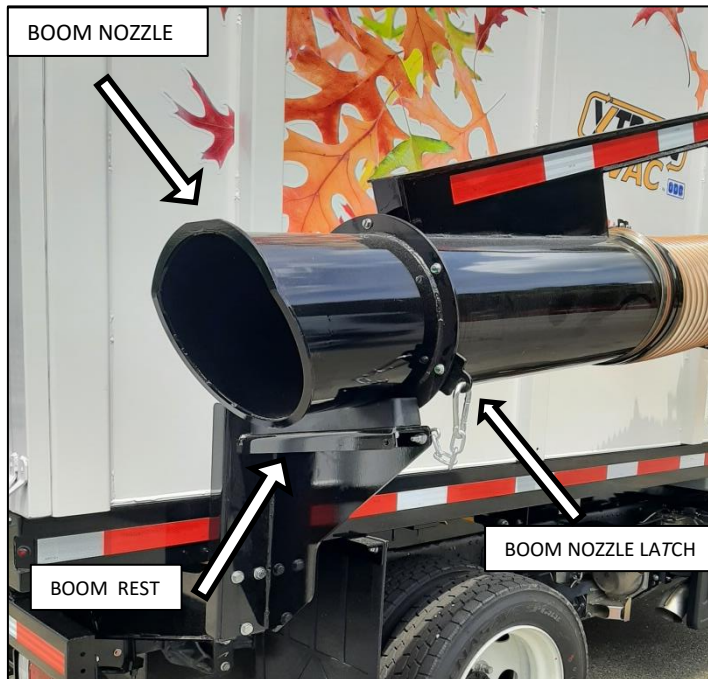

# Operating Section

## 3.3 Basic Operation – Dumping the body

### **WARNING**

**Always** ensure the dumping operation is on firm, level ground and body door is open and latched. Failure to do so **CAN** result in serious personal injury or possible death.

### Dump operation

- 1.) Unlatch the body lock doors
- 2.) Swing the body door and latch into the fully open position
- 3.) Push on the until dump is fully raised
- 4.) Once dump is complete, Pull on dump valve manual lever until dump bed is fully down
- 5.) Unlatch the dump door, and swing shut
- 6.) Latch dump door shut.



# 4.0 MAINTENANCE SECTION

## **⚠ WARNING**

Read and understand this entire manual before operating, maintaining or repairing the leaf vacuum.

## 4.0 Maintenance Section

# Maintenance Section

## 4.1 Maintenance Overview:

### CAUTION

Only properly trained personnel should perform maintenance or repair on this equipment. Consult ODB before performing any maintenance procedures that is not specifically covered in this manual. Improper maintenance or repair may void any and all warranties on this equipment.

### WARNING

Improper maintenance or repair CAN result in equipment damage and/or personal injuries.

### DANGER

**BEFORE CONTINUING**, please read and understand the Safety, Pre-operating and Operating sections of this manual before doing any procedures in this section.

A properly maintained leaf vacuum will dramatically extend the life of the unit and will create a safer workplace as well. For the general safety and welfare of all personnel it is important to create a scheduled maintenance program that covers all the elements in this manual as well as the engine, PTO and axle owner's manuals provided with this unit.

Use the chart on the following page as a guide for your scheduled maintenance program. If there are any questions concerning any of these procedures please call ODB.

# Maintenance Section

## 4.2 Maintenance and Lubrication

This chart is only a reference, always **consult the Owners Manual of the Engine, PTO, etc for actual recommendations (Use Hour Meter as a Guide)**

MAINTENANCE	INTERVAL					
	Daily	First 8 Hours	Every 25 Hours	Every 50 Hours	Every 100 Hours	Every 200 Hours
Check and add engine oil, coolant, fuel and Hydraulic fluid (hoist and boom)*	●					
Check for loose nuts or bolts	●					
Check for fuel, oil, coolant and hydraulic leakage*	●					
Check or clean radiator screen	●					
Lubricate impeller shaft flange bearings(if equipped)	●					
Check lug nuts and tire pressure / condition	●					
Check trailer safety chains and hitch	●					
Check tow bar for damage or wear	●					
Check and clean instrument panel and circ. board	●					
Clean pre-cleaner	●					
Check air filter for dirt or debris*	●					
Check trailer lighting and trailer brake operation	●					
Change engine oil* (for <b>break in</b> oil see EOM)		●			●	
Clean and check battery and connections*			●			
Check power band tension (if equipped)			●			
Check power band condition (if equipped)			●			
Check impeller for damage, cracks or wear			●			
Grease (non-conductive) circuit board connectors			●			
Clean hydraulic pump motor/connections			●			
Lubricate throttle and choke cables				●		
Check blower housing liners for cracks or wear				●		
Check Clutch/PTO linkage adjustment				●		
Change hoist hydraulic fluid and filter		●			●	
Change boom hydraulic fluid					●	
Inspect intake and exhaust hoses for damage					●	
Check exhaust duct gasket for wear	●					
Replace oil filter*					●	
Replace air filter primary element*					●	
Inspect radiator and hoses*					●	
Check fan belt conditions and tension*					●	
Inspect all duct work for cracks, holes or wear	●					
Grease / Inspect wheel bearings for corrosion					●	
Change engine coolant*						●
Check fuel tank for leaks						●
Lubricate Hoist and Hinge Fittings						●

\* = see the engine owner's manual for complete details



# Maintenance Section

## 4.3 Lubrication

### ⚠ CAUTION

Remove the negative battery terminal before attempting any lubrication procedures.

### ⚠ WARNING

Thoroughly read and understand the safety and pre-operating sections of this manual before performing any lubrication procedures.



The following are general lubrication procedures for our standard units. Any special or custom built units may have other lubrication procedures not directly mentioned in this manual. Please consult ODB before any lubrication procedures not specifically mentioned in this manual.

Proper lubrication of your unit correlates directly to how long your unit will last. A properly maintained unit will last much longer than a unit that is not maintained properly. **NOTE:** Always lubricate bearings at the end of each work day. This will displace any moisture in the bearings. Also lubricate thoroughly before extended shutdown or storage.

### Lubrication Points:

1. **Drive Bearings (figure 4.3a):** These bearings are critical components of the belt-driven units. These bearings should be greased every 10 hours with approximately two strokes from the average hand pump grease gun. The type of grease used in these bearings are also critical to the performance of the bearings. A multi-purpose, heavy-load, high temperature, moisture resistant #2 grease is required for the drive bearings. ODB recommends Mantek Elite Supreme #1 WG Extreme Duty multi-purpose grease. Other premium quality grease that matches the above requirements may be used but after years of testing ODB recommends the Elite Supreme grease.

**NOTE:** DO NOT mix different types of grease. The old grease MUST BE purged before a different type of grease is used. Mixing grease WILL cause premature failure to the bearings.



# Maintenance Section

Figure 4.3b

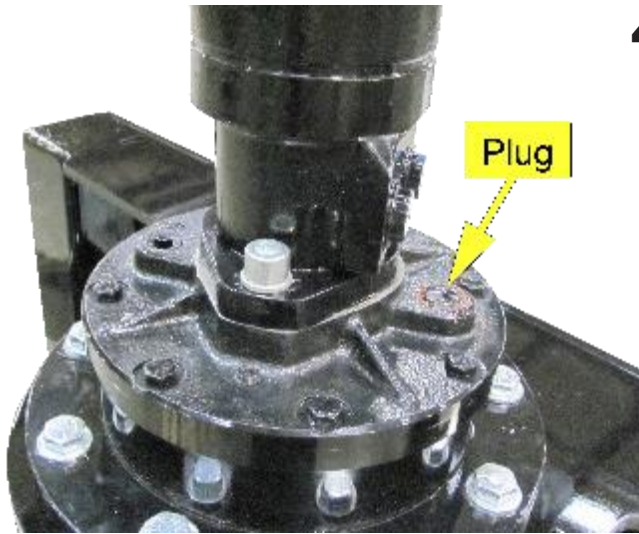

## 4.3 Lubrication, continued;

### Lubrication Points, continued:

2. **Auburn Gear Oil (figure 4.3b):** Fill Auburn gear with 90W gear oil. Undue plug as shown and fill. There is a plug at the bottom for draining if necessary.
3. **Boom Swivel (figure 4.3c):** Grease the boom bearings once every week with a multi-purpose moisture resistant #2 grease.
4. **Hinge and Friction Points:** Leaf vacuum operation and longevity can be improved by keeping hinges and friction points lubricated. ODB recommends that lubrication be performed weekly. Use SAE30 weight oil on hinges and a premium grade, high temperature lithium based EP#2 grease on friction points.

Figure 4.3c

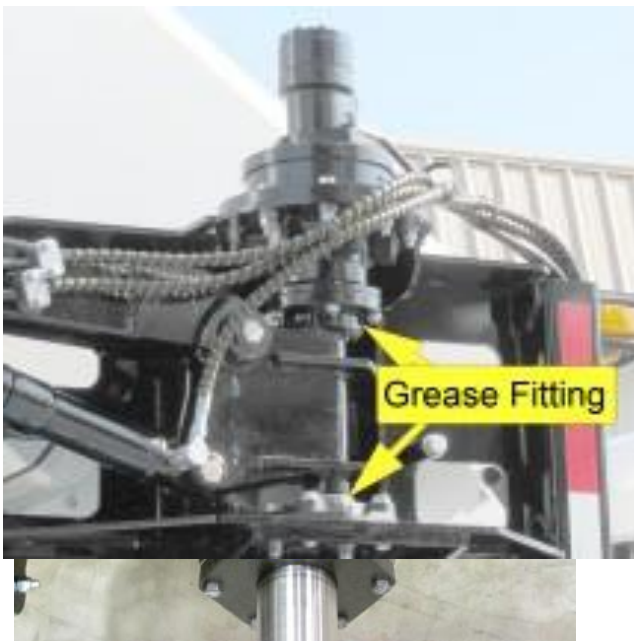

# Maintenance Section

## 4.3 Lubrication, continued;

### Lubrication Points, continued:

Figure 4.3e

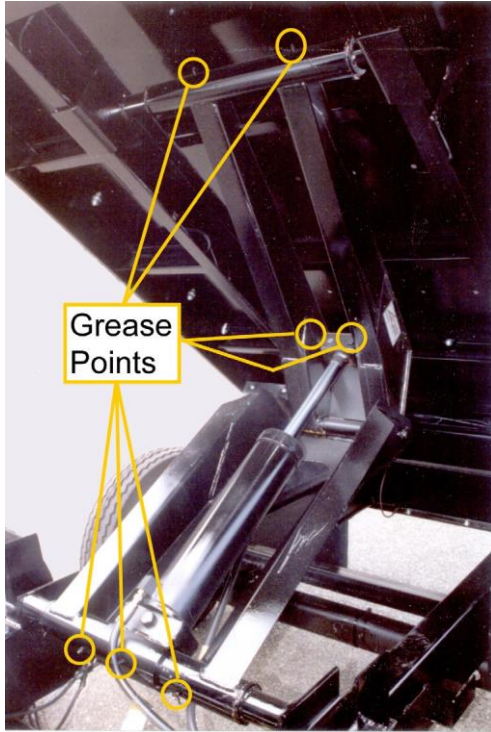

### **⚠ WARNING**

Never go under the dump body unless the body is empty and the body prop(s) is in the proper position.

### **⚠ WARNING**

The body prop is designed and intended to support an **EMPTY** truck body in the raised position. Unload the body before using the body prop(s).

Figure 4.3f

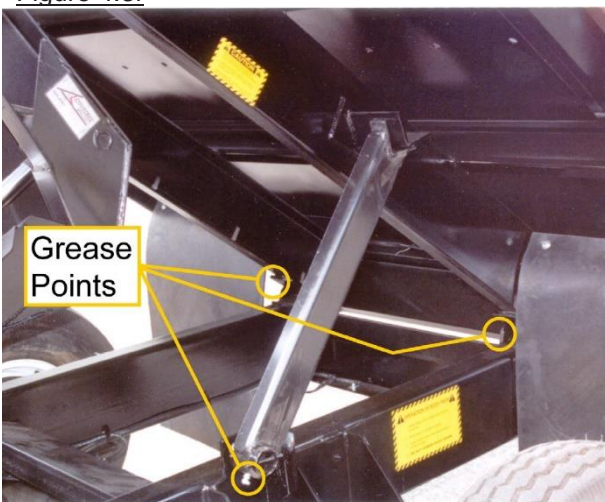

5. **Hydraulic Hoist Fittings (figure 4.3e):** Raise and support the dump body as detailed in section 3.2. Lubricate the fittings at least every 200 hours of operation with a #2 high grade grease. There are tremendous forces on the bearing surfaces within the hoist frame. It pays to be generous with the grease gun, to insure proper operation and long life.
6. **Hoist Hinge and Body Prop(s) Fittings (figure 4.3f):** Each hinge pivot has a grease fitting that needs lubricating every 200 hours. The body prop(s) has a fitting at the pivot area as shown in figure 4.3h.

## 4.4 Preventative Maintenance

### ⚠ CAUTION

Remove the negative battery terminal before attempting any maintenance procedures.

### ⚠ WARNING

Thoroughly read and understand the safety and pre-operating sections of this manual before performing any maintenance procedures.

The following are general preventative maintenance procedures for our standard units. Any special or custom built units may have other preventative maintenance procedures not directly mentioned in this manual. Please consult ODB before doing any preventative maintenance procedures not specifically mentioned in this manual.

Proper preventative maintenance of your unit, just like lubrication, correlates directly to how long your unit will last. A properly maintained unit will last much longer than a unit that is not maintained properly.

### Preventative Maintenance:

**Engine Oil:** Change the oil and oil filter according to schedules provided in your engine's owner's manual (EOM). The engine oil level should be checked every day. The level should be checked after the engine has been stopped for a period of time. This will allow the oil to drain back into the oil pan, allowing a better indication of the true oil level. If the level is low, see the engine's owner's manual for the correct type of oil.

**Engine Coolant:** Check the coolant level before starting the unit each day. The coolant level should not be less than one inch below the top of the radiator.

### ⚠ CAUTION

**NEVER** check the engine coolant when the engine is hot. Allow the engine to cool at least one hour before checking the coolant. Check the engine owner's manual for instructions. **ALWAYS** wear eye and hand protection when working with the radiator.

# Maintenance Section

## 4.4 Preventative Maintenance, continued;

### Preventative Maintenance, continued:

**Engine Radiator:** The engine radiator on a leaf vacuum becomes clogged with dust and debris frequently because of the nature of the job. If the radiator is not cleaned properly it WILL cause improper cooling and WILL eventually cause serious damage to your engine. The debris accumulating on the radiator can be lessened by lowering the RPM on the engine to a level just enough to vacuum the leaves. The higher the RPM the more dust that is put into the air. Also, it may be necessary to put mesh or tarps on the top of the leaf box container to reduce the debris and dust. If this is done, make sure there is enough air ventilation on the box, so the box is not blown apart. Proper belt condition and coolant mix-ratio, as well as coolant conditioners, are all critical to proper engine cooling. See the engine's owner's manual for specifics on coolant mixture ratios and conditioners. The radiator should be inspected and cleaned with compressed air every day at the very least.

### DANGER

**NEVER attempt to clean or inspect the radiator with the engine running or while the engine is HOT. Allow the engine to cool at least one hour before maintaining the radiator. Check the engine owner's manual for instructions. ALWAYS wear eye and hand protection when working with the radiator.**

**Engine Air Cleaner:** Due to the large amounts of dust generated in collection leaves, it is critical to your engine's life that the pre-cleaner and air filter be maintained properly. The pre-cleaner should be cleaned at least daily of any debris that has accumulated. If conditions warrant it should be cleaned more. The air filter should be checked daily and should be replaced at the first sign of it being dirty. DO NOT attempt to clean the air filter, replace the dirty air filter. It is a good idea to clean out the air filter housing once a week to clean any dust debris that may have accumulated.

**Tires and Wheels:** Tires and wheel lug nuts should be checked daily. Tires should be checked for excessive wear and proper air pressure. Check the side wall of the tire for proper inflation pressure. Torque all 1/2" diameter lug nuts from 90 to 120 foot-pounds. Torque all 5/8" diameter lug nuts from 175 to 225 foot-pounds. Consult the axle manufacturer's owner's manual for more detailed information.

# Maintenance Section

## 4.4 Preventative Maintenance, continued;

### Preventative Maintenance, continued:

**Trailer Brakes (if equipped):** Most of the newer ODB leaf vacuums have electric brakes on the axle(s). It is critical that these brakes work properly. The trailer's brakes should be checked daily, before leaving the equipment yard, for proper operation. The trailer brakes are designed to work in synchronization with your tow vehicles brakes. Never use your tow vehicle or trailer brakes alone to stop the combined load. The synchronization between the tow vehicle and the leaf vacuum is accomplished through the brake controller and needs to be set correctly. Please read the brake controllers manual and the axle owner's manual for these procedures.

### **⚠ WARNING**

**DO NOT tow the leaf vacuum with damaged or non-operating brakes. Check the brakes daily for proper operation.**

The brakes should be adjusted after the first 200 miles of operation when the brake shoes and drums have "seated" and at 3,000 mile intervals, or as use and performance requires. The adjustment procedures are beyond the scope of this manual, please see the axle owners/service manual for specific instructions.

The trailer brakes should be inspected and serviced at yearly intervals or more often as use and performance requires. Magnets and shoes must be changed when they become worn or scored thereby preventing adequate vehicle braking. Again, see the axle owner's/service manual for specific procedures.

**FUEL TANK:** Fill the fuel tank at the beginning of the work shift leaving a gap of at the top of the tank for expansion of fuel. A full fuel tank will reduce the possibility of condensation forming in the tank and moisture entering the fuel lines. Check the fuel lines daily for cracks, holes or tightness.

# Maintenance Section

## 4.4 Preventative Maintenance, continued;

### Preventative Maintenance, continued:

#### CAUTION

**ALWAYS** wear eye and hand protection when working with the battery.

**BATTERY:** ODB's units are supplied with "maintenance free" batteries so there is no need to check fluid levels, but the battery terminals should be checked daily for corrosion. Remove any corrosion with a wire brush and coat the terminals with light grease or petroleum jelly to reduce the possibility of corrosion. Also check the battery cable for wear all cable connections and battery tie downs to be certain that they are not loose.

**DRIVE BELT (if equipped):** The main drive belt should be checked daily for cracks and for proper tension. If the belt shows any sign of

#### CAUTION

**Remove the negative battery cable before opening the belt guard.**

cracking it should be replaced immediately. The proper tension of the belt should be approximately 1/2" deflection when applying a 8 pound pull.

**FASTENERS:** Fasteners should be checked weekly for the first 30 days and monthly thereafter. They must be in place at all times and properly torqued. For general torque values see the torque chart at the end of this section.

**INSTRUMENT PANEL AND CIRCUIT BOARD:** The instrument panel and circuit board should be cleaned with compressed air daily. Also the circuit board connectors should be wiped clean and have non conductive grease applied weekly to help maintain solid connections.

**BOOM HYDRAULIC RESERVOIL:** Check the fluid level daily. If fluid needs to be added, All-Temp-NZ Hydraulic fluid (46) is recommended. Clean debris and oil off the solenoid and pump daily. A build up of debris can cause premature failure to the pump. Check and tighten all hydraulic fittings making sure there are no leaks.

# Maintenance Section

## 4.4 Preventative Maintenance, continued;

### Preventative Maintenance, continued:

**Hoist Hydraulic Fluid:** The hoist hydraulic fluid and should be changed every 250 hours of operation. The fluid should be completely drained and fresh high-quality **Dextron II (Automatic Transmission Fluid)** should be added.

### CAUTION

**ALWAYS raise and support the box container properly using the steps outlined in this manual.**

**Exhaust Duct Gasket:** The 1.5" thick gasket should be checked for wear every 200 hours. This gasket creates a tight seal between the box container and the blower housing.





**Axle Hangers:** The hanger bolts should be checked periodically for tightness and wear.

**Hydraulic Fittings:** Check all hydraulic fittings for leaks and tightness. Any leak could become a hazard, fix immediately.



# Maintenance Section

## 4.5 Torque Values

<u>INCH</u> BOLT AND CAP SCREW TORQUE VALUES					<u>METRIC</u> BOLT AND CAP SCREW TORQUE VALUES						
TYPE	SAE GRADE					CLASS					
	5		8			8.8 or 9.8		10.9		12.9	
HEAD MARK					HEAD MARK						
SIZE(D)	LB-FT		LB-FT		SIZE(D)	LB-FT		LB-FT		LB-FT	
	Lub*	Dry*	Lub*	Dry*		Lub*	Dry*	Lub*	Dry*	Lub*	Dry*
1/4"	7	9	10	12.5	M6	6.5	8.5	9.5	12	11.5	14.5
5/16"	15	18	21	26	M8	16	20	24	30	28	35
3/8"	26	33	36	46	M10	32	40	47	60	55	70
7/16"	41	52	58	75	M12	55	70	80	105	95	120
1/2"	63	80	90	115	M14	88	110	130	165	150	190
9/16"	90	115	130	160	M16	140	175	200	255	240	300
5/8"	125	160	175	225	M18	195	250	275	350	325	410
3/4"	225	280	310	400	M20	275	350	400	500	460	580
7/8"	360	450	500	650	M22	375	475	540	675	625	800
1"	540	675	750	975	M24	475	600	675	850	800	1000
1-1/8"	675	850	1075	1350	M27	700	875	1000	1250	1150	1500
1-1/4"	950	1200	1500	1950	M30	950	1200	1350	1700	1600	2000
1-3/8"	1250	1550	2000	2550	M33	1300	1650	1850	2350	2150	2750
1-1/2"	1650	2100	2650	3350	M36	1650	2100	2350	3000	2750	3500

\***Lub** means coated with a lubricant such as engine oil, or fasteners with phosphate or oil coatings. "Dry" means plain or zinc plated without any lubrication.

DO NOT use these values if a different torque value or tightening procedure is given for a specific application. Torque values listed are for general use only. Check tightness of fasteners periodically.

Make sure fastener threads are clean and that you properly start thread engagement. This will prevent them from failing when tightening. Fasteners should be replaced with the same or higher grade. If higher grade fasteners are used, these should only be tightened to the strength of the original.

Tighten plastic insert or crimped steel-type lock nuts to approximately 50 percent of the dry torque shown in the chart, applied to the nut, not the bolt head.

# Maintenance Section

## 4.6 Kraft Fluid Drive Maintenance (Optional)

Controllare, ogni 3 mesi, il livello dell'olio nel giunto. Cambiare l'olio ogni 4000 ore di funzionamento oppure una volta all'anno.	Check, every 3 months, the fluid coupling oil level. Change oil every 4000 working hours or once a year, whichever occurs first.
Ingrassare il cuscinetto dell'albero di uscita ogni settimana.	Grease output shaft bearing every week.
Controllare, periodicamente, lo stato dei blocchetti in gomma del giunto elastico.	Check, periodically, elastic coupling rubber blocks condition.
E' consigliabile, ogni 4000 ore di funzionamento, cambiare tutti gli anelli di tenuta rotante e controllare lo stato dei cuscinetti.	It is advisable, every 4000 working hours, to change all rotating seals and to check bearings condition.
Controllare, periodicamente, che la taratura del termostato, se installato, sia uguale al valore originariamente impostato (vedere certificato di collaudo e TF5941-O).	Check, periodically, that temperature switch whether installed, set value be the same as originally adjusted (see test certificate and TF5941-O).
Pulire periodicamente la sonda del termostato, se installato.	Clean periodically the temperature switch bulb, whether installed.

TABELLA INCONVENIENTI		
SINTOMO	CAUSA	RIMEDIO
Scarse prestazioni	Livello olio	Controllare il livello (olio freddo) ed aggiungere se necessario Controllare la macchina condotta Controllare i giri del motore.
	Tipo olio	Utilizzare olio indicato in tabella
Surriscaldamento	Sforamento eccessivo	Controllare il livello olio Verificare l'installazione Controllare i giri del motore
	Scarse ventilazione	Pulire le aperture per la ventilazione.
	Cuscinetto non lubrificato	Verificare il livello olio ed eventualmente aggiungere.
	Cuscinetto in usura danneggiato	Sostituire
	Carico radiale eccessivo	Ridurre la tensione delle cinghie
Perdita olio lato motore	Tappo conico	Rimontare con sigillante per filetti
	Anello CR	Sostituire
	Tenuta rotante	Sostituire. Controllare l'usura sull'albero.
Perdita olio lato uscita	Tappo conico	Rimontare con sigillante per filetti
	Tappo fusibile se installato	Sostituire
	Anelli CR	Sostituire
	Tenuta Rotante	Sostituire. Controllare l'usura sull'albero.
Rumore	Rottura cuscinetto	Sostituire
	Olio con troppa schiuma	Controllare il livello ed il tipo di olio
	Usura eccessiva giunto elastico (vibrazioni torsionali?, temperatura eccessiva?, disallineamento?, olio.)	Smontare e sostituire i blocchetti ed il giunto elastico completo.
	Usura della dentatura tra albero uscita morzo, girante interna.	Smontare e sostituire le parti usurate
	Alta temperatura olio	Vedere "surriscaldamento"
Intervento termostato	Errata taratura termostato	Vedere certificato di collaudo e TF 5941-O

TROUBLE SHOOTING		
SYMPTOM	CAUSE	REMEDY
Poor performances	Oil level	Check level (cold oil) and add as necessary. Check driven machine. Check engine rpm.
	Oil type	Use recommended oil (see table)
Overheating	High slip	Check oil level. Check installation. Check engine rpm.
	Low ventilation	Clean ventilation openings
	No lubricated bearing	Check oil level. Add oil if required.
	Damaged output bearing	Replace.
	Too high radial load.	Decrease belt tension.
Oil leakage at engine side.	Taper plug	Remount using thread sealant.
	O-ring	Replace.
	Rotating seal	Replace. Check shaft wear.
Oil leakage at output side.	Filling plug	Remount using thread sealant.
	Fusible plug whether installed	Replace.
	O-ring	Replace.
	Rotating seal	Replace. Check shaft wear.
Noise	Bearing failure	Replace.
	Too much oil foam.	Check oil level and type.
	Elastic coupling wear (Torsional vibration ? high temperature ? misalignment ? oil ?).	Dismantle and replace rubber blocks or complete elastic coupling.
	Spline wear between output shaft/hub, inner impeller	Dismantle and replace worn components
	High oil temperature.	See "overheating".
Temperature switch intervention.	Wrong switch setting	See test certificate and TF 5941-O

#8217-3	08/04/01	TRANSFLUID S.r.l. via V.Monti 19-20016 Pero (MI) Italy tel.0039-02-339315.1 - fax.0039-02-33910699 - www.transfluid.it - e-mail:info@transfluid.it
---------	----------	---

 **CAUTION**

**DO NOT ATTEMPT TO OPERATE  
OR REPAIR  
THE LEAF COLLECTOR WITHOUT FIRST  
READING AND UNDERSTANDING THIS  
MANUAL**

IF YOU HAVE ANY QUESTIONS CONCERNING THE  
INSTALLATION OR OPERATION OF THIS UNIT, PLEASE CALL  
ODB FOR ASSISTANCE BEFORE ATTEMPTING TO REPAIR OR  
OPERATE THE UNIT.

**IMPROPER USE OF ANY MACHINE CAN  
RESULT IN SERIOUS INJURY!**

**STUDY AND FOLLOW ALL SAFETY  
PRECAUTIONS BEFORE OPERATING OR  
REPAIRING UNIT**

THIS MANUAL IS AN INTEGRAL PART OF THE LEAF COLLECTOR AND  
SHOULD BE KEPT WITH THE UNIT WHEN IT IS SOLD.

**ODB COMPANY**  
5118 Glen Alden Drive





## **5.0 Service Section**

**ODB COMPANY**  
5118 Glen Alden Drive  
Richmond, VA 23231  
**800-446-9823**

# Service Section

## 5.1 Removing Blower Housing Face

figure 5.1a

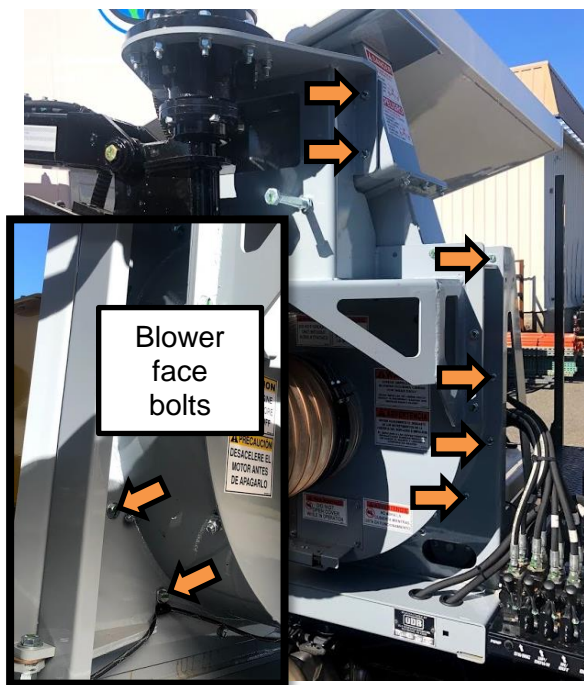

### **⚠ WARNING**

Thoroughly read and understand the safety and pre-operating sections of this manual before working on the unit.

### **⚠ WARNING**

Make sure the negative battery cable is disconnected before opening the blower.

Review the safety section of this manual before attempting these procedures.

### Removing Blower Housing Face (refer to 5.1a and 5.1b):

figure 5.2a



1. Raise and support the dump body as detailed in section 3.2-3.3.
2. Uncradle the boom and swing all the way to the front, and put the in-out boom all the way in with the nozzle four inch off of the ground.
3. Unbolt the ring of bolts connected the blower face to the pedestal (figure 5.1a). and swing frame outward using the service hinge (figure 5.2 a).



## 5.2 Replacing the Drive Bearings

figure 5.3a

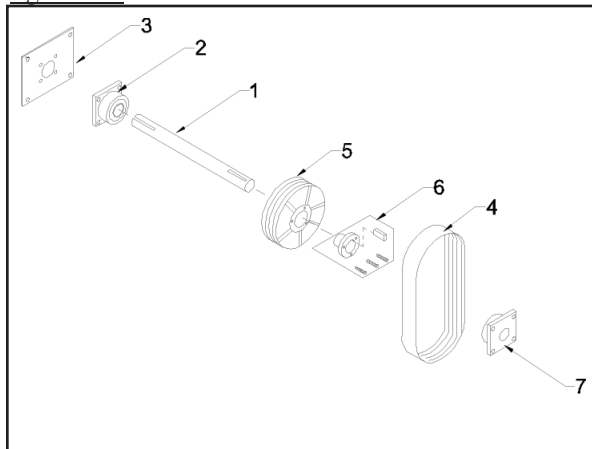

### **⚠ WARNING**

Thoroughly read and understand the safety and pre-operating sections of this manual before working on the unit.

### **⚠ WARNING**

Make sure the negative battery cable is disconnected before opening the blower housing.

Review the safety section of this manual before attempting these procedures.

figure 5.3b

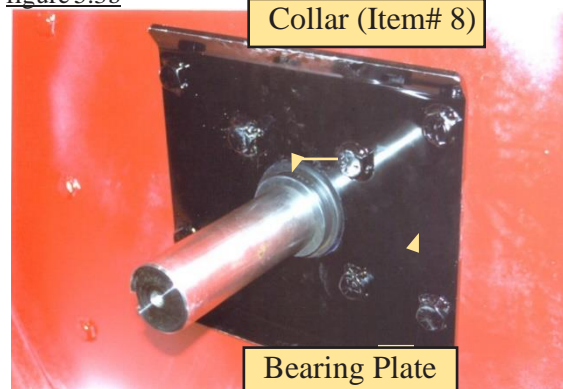

### **Removing Drive Bearings (refer to 5.3a thru 5.3d):**

1. Remove the impeller and drive belt as described in this manual.
2. If the bearings have not "seized" onto the shaft then removal is straightforward.
3. Loosen the pulley (item# 5, fig. 5.3a) by removing the bushing bolts (item# 6, fig. 5.3a).
4. Remove the bearing collar (Item# 8, fig. 5.3b), if equipped, at the rear of the front bearing (the bearing closest to the blower housing).
5. On the rear bearing (closest to the engine) loosen the set screw on the bearing lock collar (fig. 5.3c)
6. Using a punch, loosen the lock collar. (fig. 5.3d)
7. Pull the shaft out toward the blower housing. The bearing plate, front bearing and pulley should come out in one unit.

figure 5.3c



figure 5.3d



## 5.2 Replacing the Drive Bearings Cont.

Review the safety section of this manual before attempting these procedures.

figure 5.3a

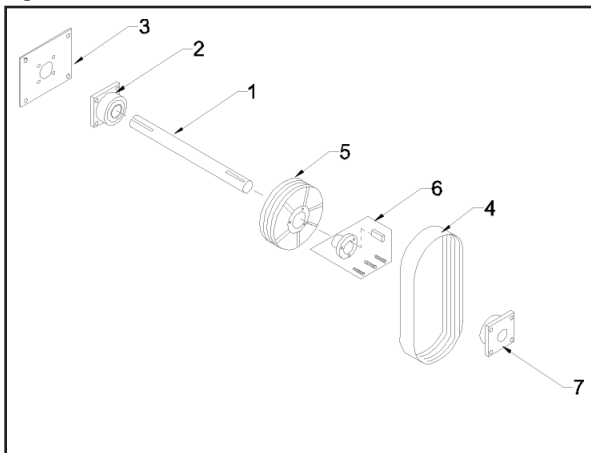

### Removing the Drive Bearings, continued:

8. If the shaft doesn't pull out easily, lubricate the shaft generously where the shaft goes through the bearings. If the shaft still doesn't come out, the final solution is to cut the shaft in half.
9. Once the shaft is out, remove the front bearing from the shaft by using steps 5 and 6.

### Installing the Drive Bearings:

1. Make sure the shaft is clean and remove any burrs.
2. Bolt up the rear bearing (closest to the engine) to the frame.
3. Bolt the front bearing to the bearing plate
4. Bolt the bearing plate (fig. 5.3b) up to the blower housing and bearing frame.
5. Slide the shaft through the front bearing, making sure the front locking collar is slid on to the shaft.
6. Once the shaft is through the front bearing, install the pulley onto the shaft, but don't tighten it until the bearings have been installed and your sure the two pulleys are lined up correctly.
7. Slide the shaft through the rear bearing (closest to the engine). Make sure the front locking collar is put on before the bearing.

figure 5.3b

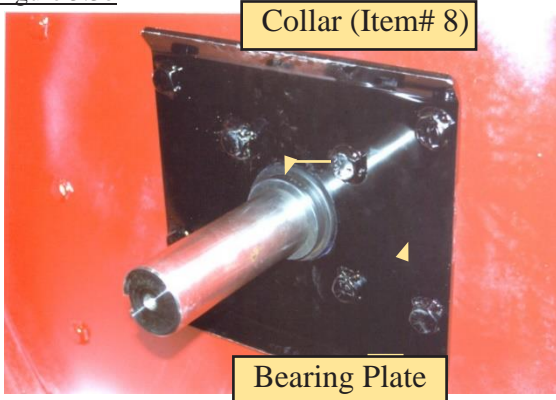

## 5.2 Replacing the Drive Bearings Cont.

figure 5.3a

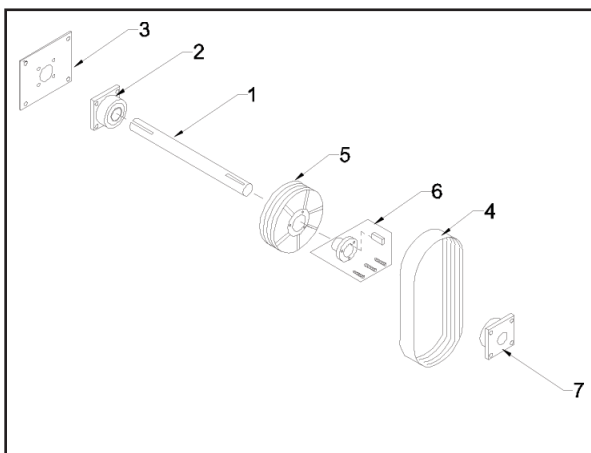

Review the safety section of this manual before attempting these procedures.

### Installing the Drive Bearings, continued:

8. Once the shaft is in place, lock down the bearings:
9. Starting with the rear bearing (closest to the blower housing) install the rear collar on the blower housing side (figure 5.3b). The rubber seal should be facing the bearing.
10. Push the steel collar up to the bearing and make sure the groove in the collar goes inside the groove in the bearing.
11. Tighten the set screw (figure 5.3e).
12. Install the front locking collar sliding the locking collar up to the bearing and then turn the collar clockwise until it slips over the inner ring extension and engages the eccentric. Turn by hand until the parts are locked together.
13. Place a punch or drift in the blind hole in the collar and strike it sharply to lock the collar and ring tightly together (figure 5.3f)
14. Tighten the set screws with an Allen wrench until the set screw stops. (figure 5.3g)
15. Do steps 11-14 for the other bearing also.
16. Line up the pulleys and tighten the busing.
17. Re-install the belt guards and impeller as described earlier.

figure 5.3b

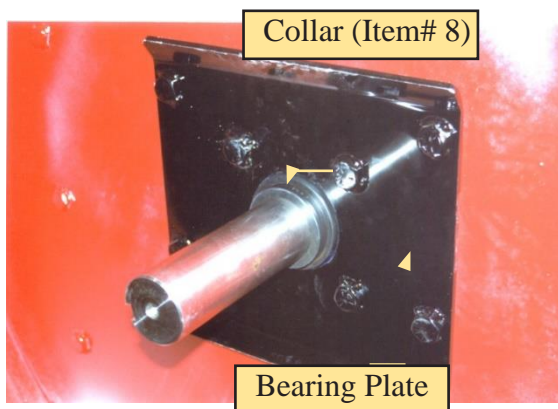

figure 5.3e



figure 5.3f



figure 5.3g





## 5.3 Impeller Installation and Removal

### REMOVAL



**CAUTION:** Before removing the blower housing face remove the negative battery cable to ensure unit can not be started.

1. The blower housing face must be removed to gain access to the impeller. Use an overhead crane or forklift to support the face while removing.
2. Once the face has been removed, remove the shaft protector (Fig. 1 or 2).
3. Saturate the shaft and bushing using a penetrating lubricant to help loosen the bushing. Clean any grease or debris from the bushing and shaft.
4. Remove the 3 bolts attaching the bushing to the impeller.(Fig. 3) Being careful not to break the bolts. If a set screw is on the lip of the bushing, loosen it using an allen wrench.(Fig. 4)
5. Using two of the bolts that were just removed screw those bolts into the threaded holes on the bushing. Drive the two bolts into the bushing.(Fig. 5) This will separate the bushing from the impeller. Alternate from one bolt to the other driving only about a 1/4" at a time to keep the bushing coming out straight. It is imperative to keep the bushing straight to remove it.

**IMPORTANT: Be sure to drive the bushing out evenly or it will get in a bind making removal much harder.**

6. If the bushing does not come off using the two bolts, drill and tap several additional 3/8-16 holes around the bushing. Using Grade 8, 3/8-16 - 2 inch bolts, alternately drive the bolts 1/4" at a time to remove the bushing. **KEEP THE BUSHING STRAIGHT** while removing.

**IMPORTANT: If additional holes were drilled in the bushing, it can not be reused. It must be replaced.**

7. Once the bushing has been removed use an overhead crane or other suitable device to help lift the impeller out of the blower housing.
8. At this point it would be a good idea to inspect the blower housing liners and blower housing for any damage or wear. Any damage or wear to the liners should be fixed by replacing the liners immediately.

Fig. 1



Fig. 2



Fig. 3



Fig. 4

Direct  
Drive



Fig. 5

Belt  
Drive



# Service Section

## 5.3 Impeller Installation and Removal, continued

### INSTALLATION



**CAUTION:** Before removing the blower housing face remove the negative battery cable to ensure unit can not be started.

1. Clean the shaft of any debris and remove any rust using a 120 grit emory cloth.
3. Using an overhead crane or other suitable lifting device lift the impeller on to the shaft. Turn the impeller to align the keyways of the shaft with the keyway in the impeller.
4. Insert key into the keyway. A light sanding of the keyway may be needed, as well as a few light blows with a rubber mallet.
5. Tap the bushing onto the shaft aligning the keyways.
6. **BELT DRIVE UNITS:** Align the bushing and key to be flush with the end of the shaft (Fig 1).

**DIRECT DRIVE UNITS:** The bushing and key should protrude from the shaft about 1/2 inch (Fig. 2).

7. Put the 3 bolts into the non-threaded holes and drive them into the impeller holes evenly. Alternate between the three bolts as you drive the bolts in. Torque to 40 to 50 lbs/ft. There should be a gap of 3/8" to 1/2" between the bushing and the impeller.

**IMPORTANT:** Slowly spin the impeller by hand making sure that the back of the impeller is not hitting any of the bolt heads located at the back of the blower housing.

8. If the bushing has a set screw on it, tighten the screw snug with an allen wrench (Fig. 3). This will help keep the key in place.
9. Install the shaft protector on to the shaft (Fig. 4 or 5).

Fig. 1



Fig. 2



Fig. 3

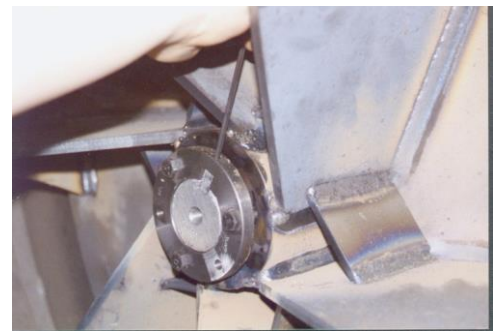

Fig. 4

Direct  
Drive



Fig.  
5

Belt  
Drive



# Service Section

## 5.4 Replacing the Blower Housing Liners

figure 5.5a

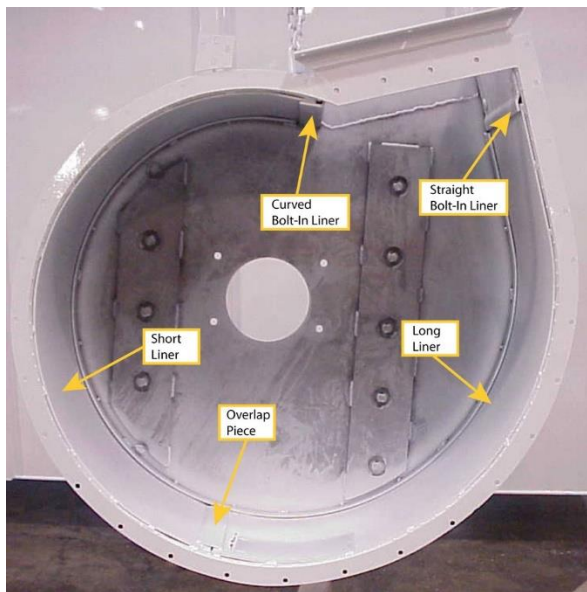

### ⚠ WARNING

Thoroughly read and understand the safety and pre-operating sections of this manual before working on the unit.

### ⚠ WARNING

Make sure the negative battery cable is disconnected before opening the blower housing.

Review the safety section of this manual before attempting these procedures. To gain access to the interior of the blower housing please see the previous sections.

### Removing and installing the Liners (refer to 5.5a and 5.5b):

### ⚠ WARNING

Keep all fuel and fuel fumes away from the unit when grinding or welding. Work only in a well ventilated area.

1. Unbolt the blower housing face as described previously in this manual.
2. Remove the curved and straight bolt-in liners by removing the appropriate bolts.
3. With a grinder cut out the remaining welds to free the liners. DO NOT remove the "stop piece" at the bottom of the housing.

figure 5.5b

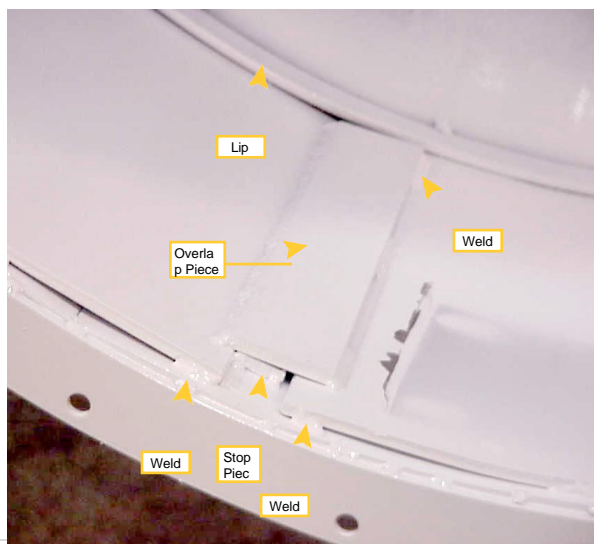

### TO INSTALL:

1. Place the short liner into lip at the rear of the housing and line up the bottom of the liner with the "stop" at the bottom of the housing. The short liner has the overlap piece on it and should be installed as shown in the pictures at the left.
2. Tack weld the liner in place every 8 to 10 inches to help keep the liner in place.

# Service Section

## 5.4 Replacing the Blower Housing Liners; continued

figure 5.5a

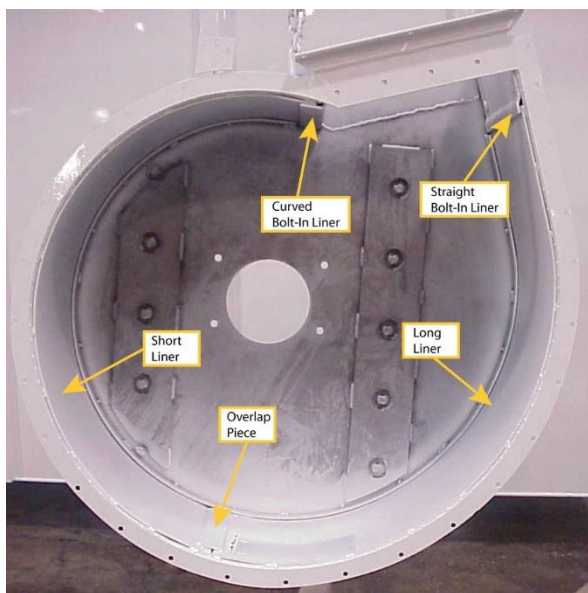

### **⚠ WARNING**

Thoroughly read and understand the safety and pre-operating sections of this manual before working on the unit.

### **⚠ WARNING**

Make sure the negative battery cable is disconnected before opening the blower housing.

Review the safety section of this manual before attempting these procedures. To gain access to the interior of the blower housing please see the previous sections.

### **Installing the Liners (refer to 5.5a and 5.5b), continued:**

### **⚠ WARNING**

Keep all fuel and fuel fumes away from the unit when grinding or welding. Work only in a well ventilated area.

3. Install the long liner the same way as the short liner except the long liner should slip under the overlap piece. Make sure the liner slips under the rear lip and the overlap piece.
4. Tack weld the long liner to the overlap piece and tack weld around the liner as you did on the short liner.
5. Install the two bolt-in liners just as they were removed.

figure 5.5b

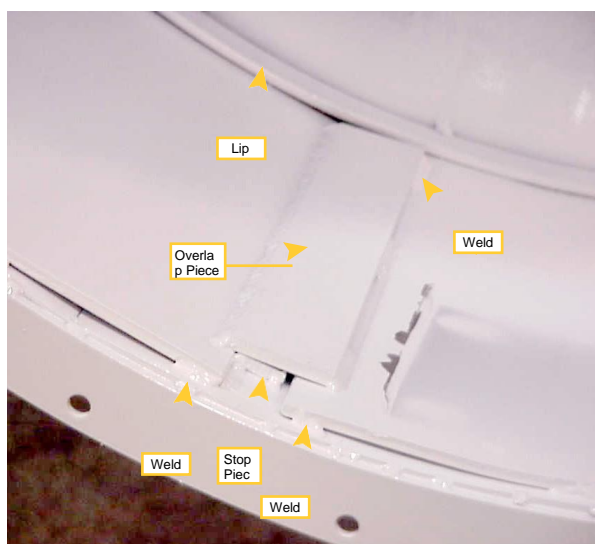

## 5.5 Hydraulic Schematic

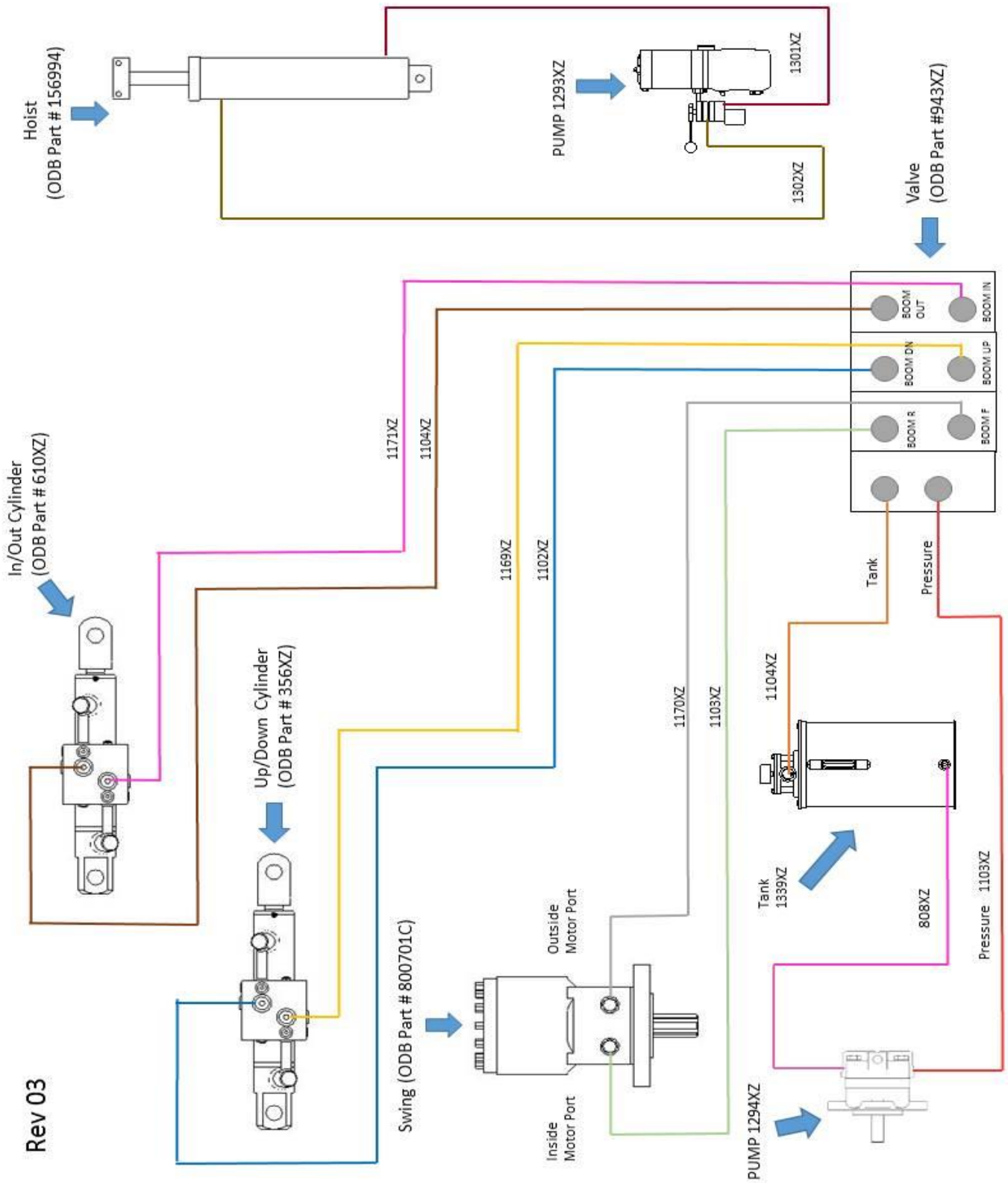

# Service Section

## 5.6 Electrical Schematic 966XZ

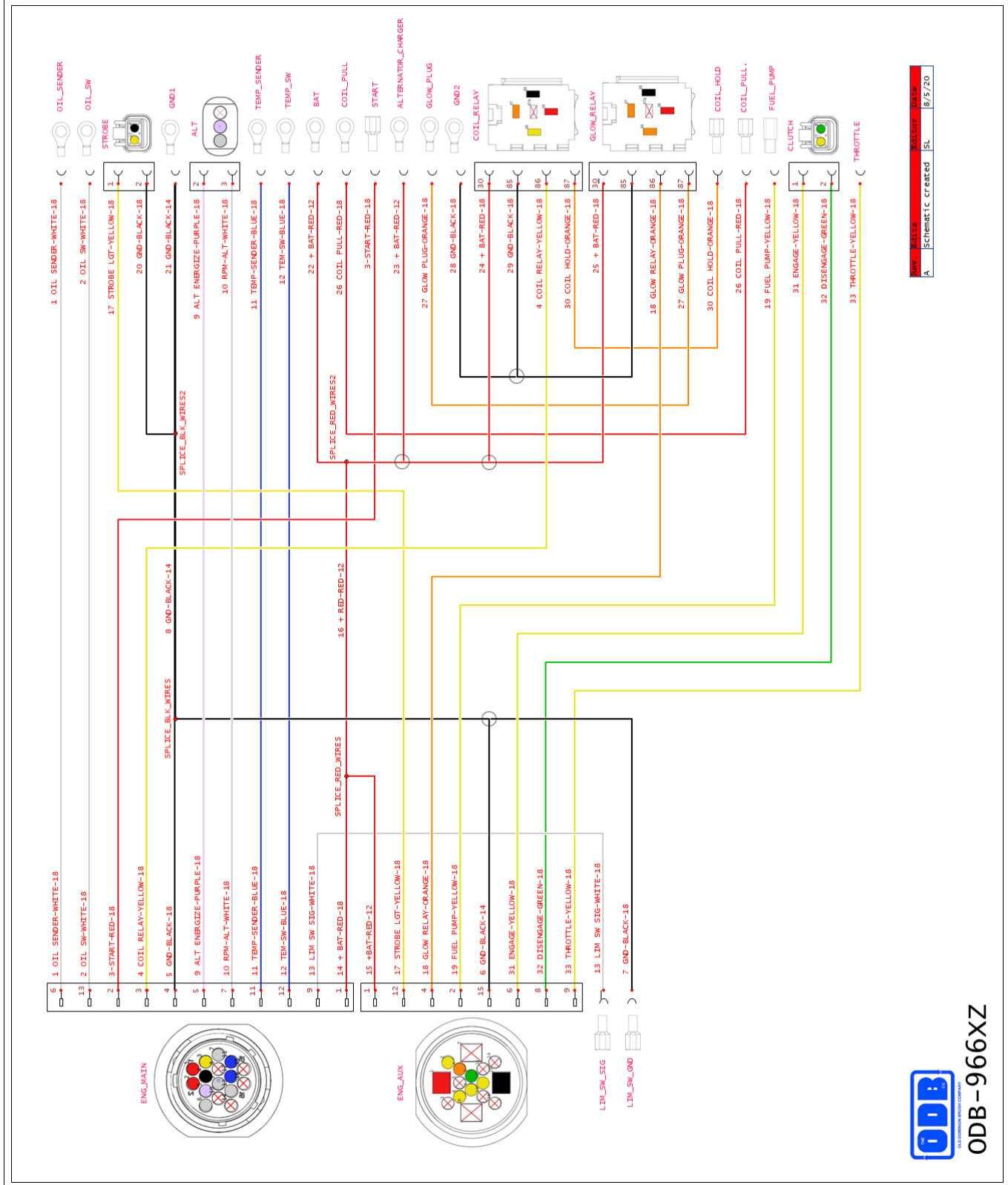

ODS - 966XZ

# Service Section

## 5.6 Electrical Schematic

### 1086XZ

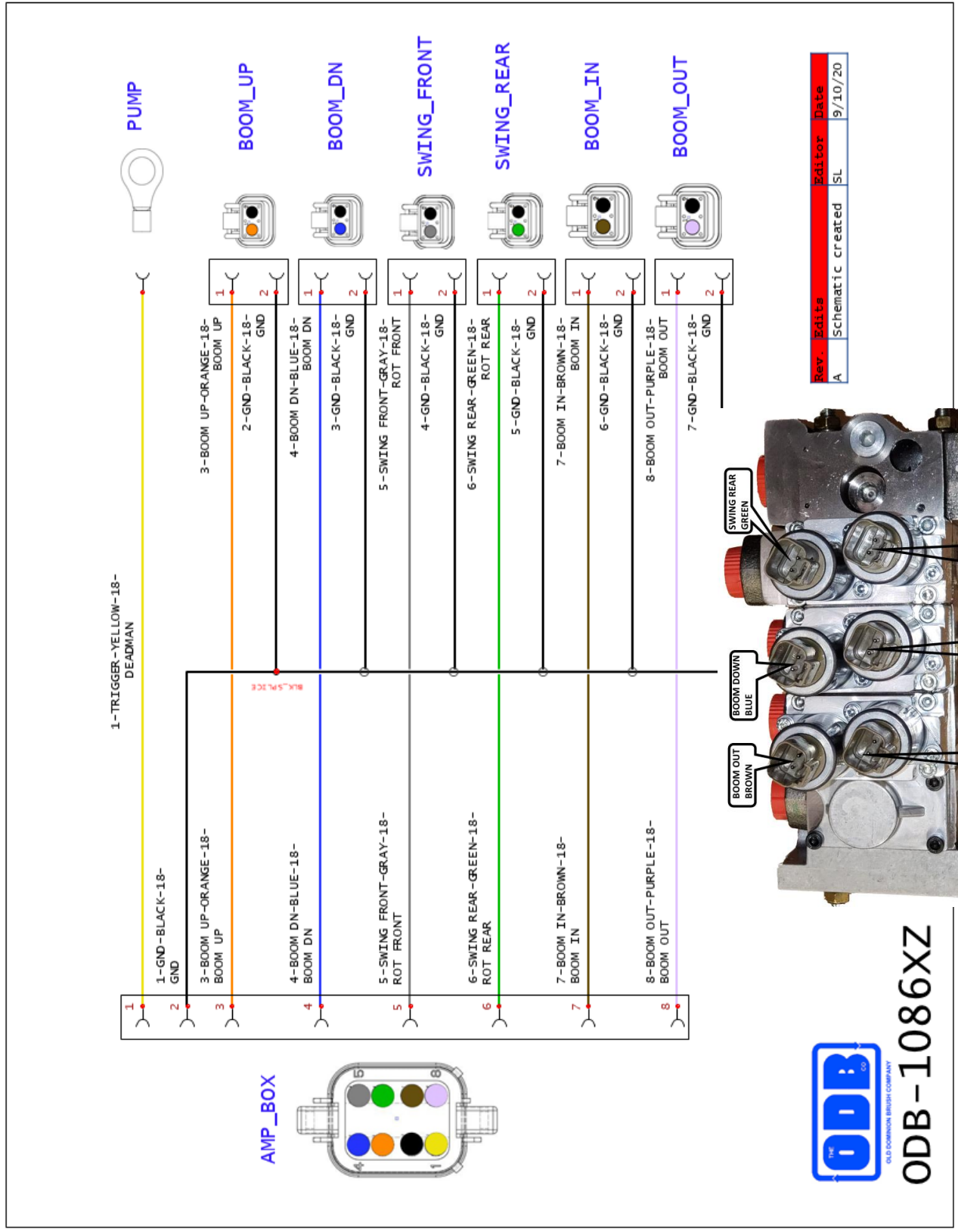

# Service Section

## 5.6 Electrical Schematic Cont.

### 1087XZ

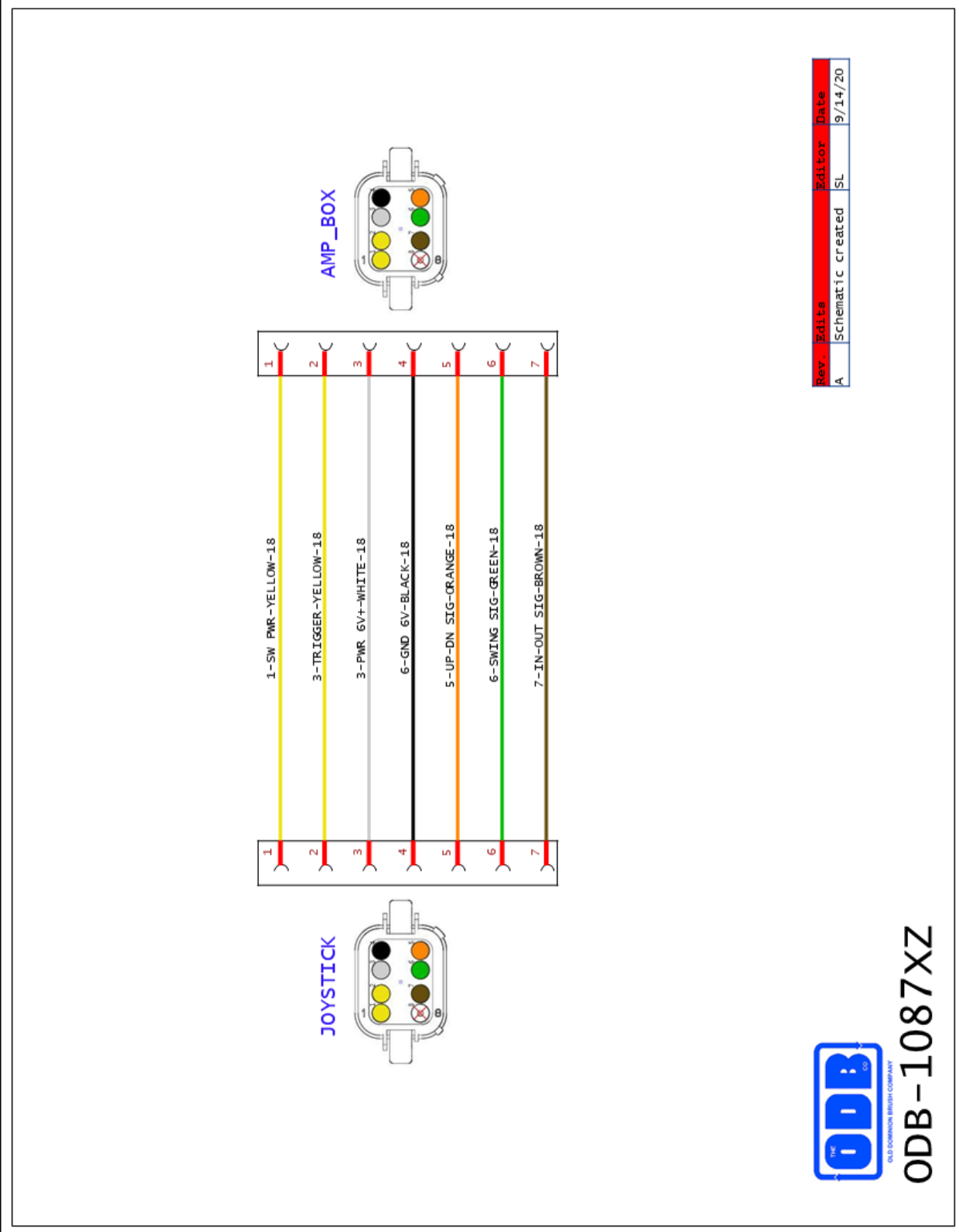

Rev.	Edits	Editor	Date
A	Schematic created	SL	9/14/20



OLD DOMINION BRUSH COMPANY

# ODB-1087XZ



# Service Section

## 5.6 Electrical Schematic Cont.

### 1088XZ

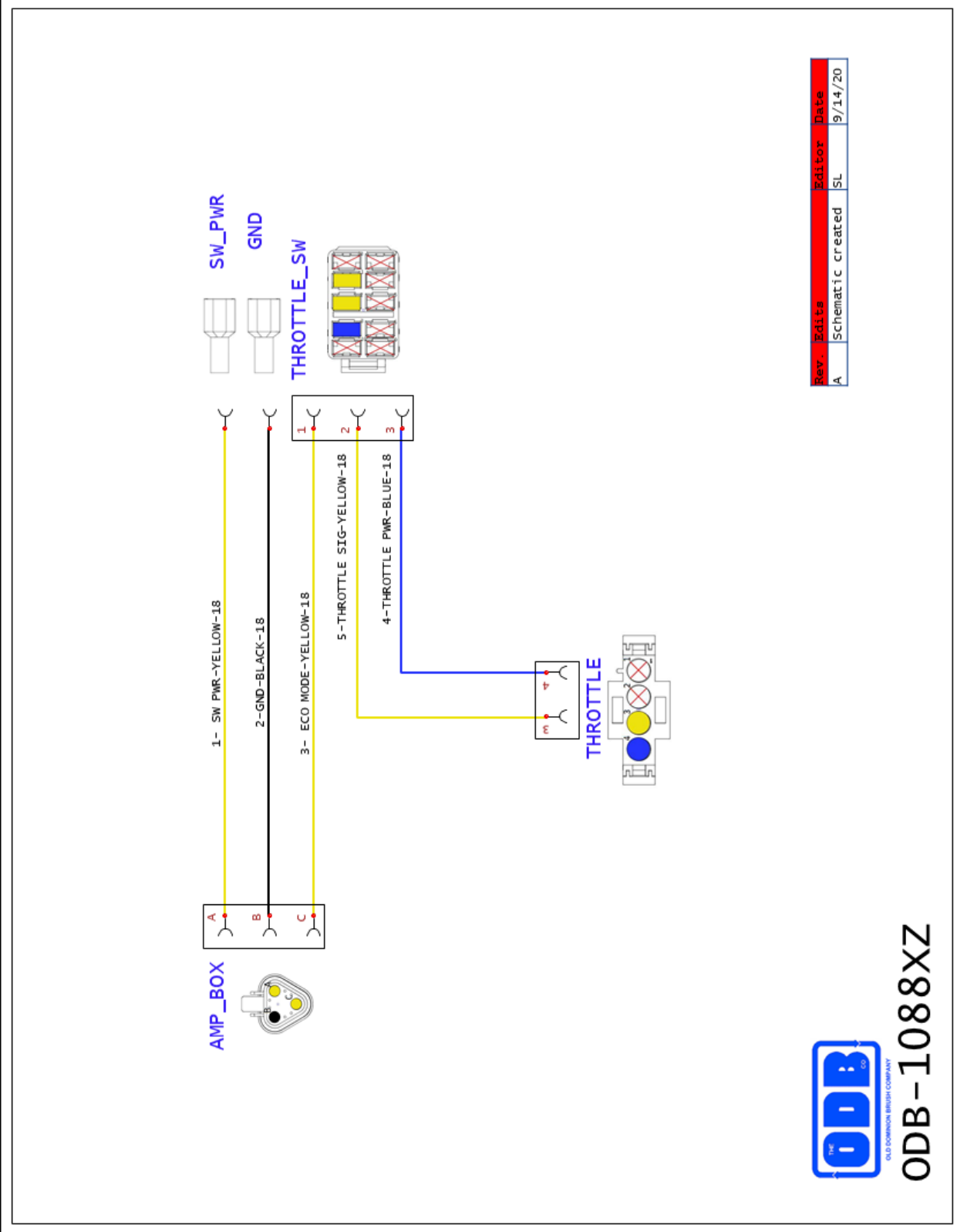

# Service Section

## 5.6 Electrical Schematic Cont.

### 1093XZ

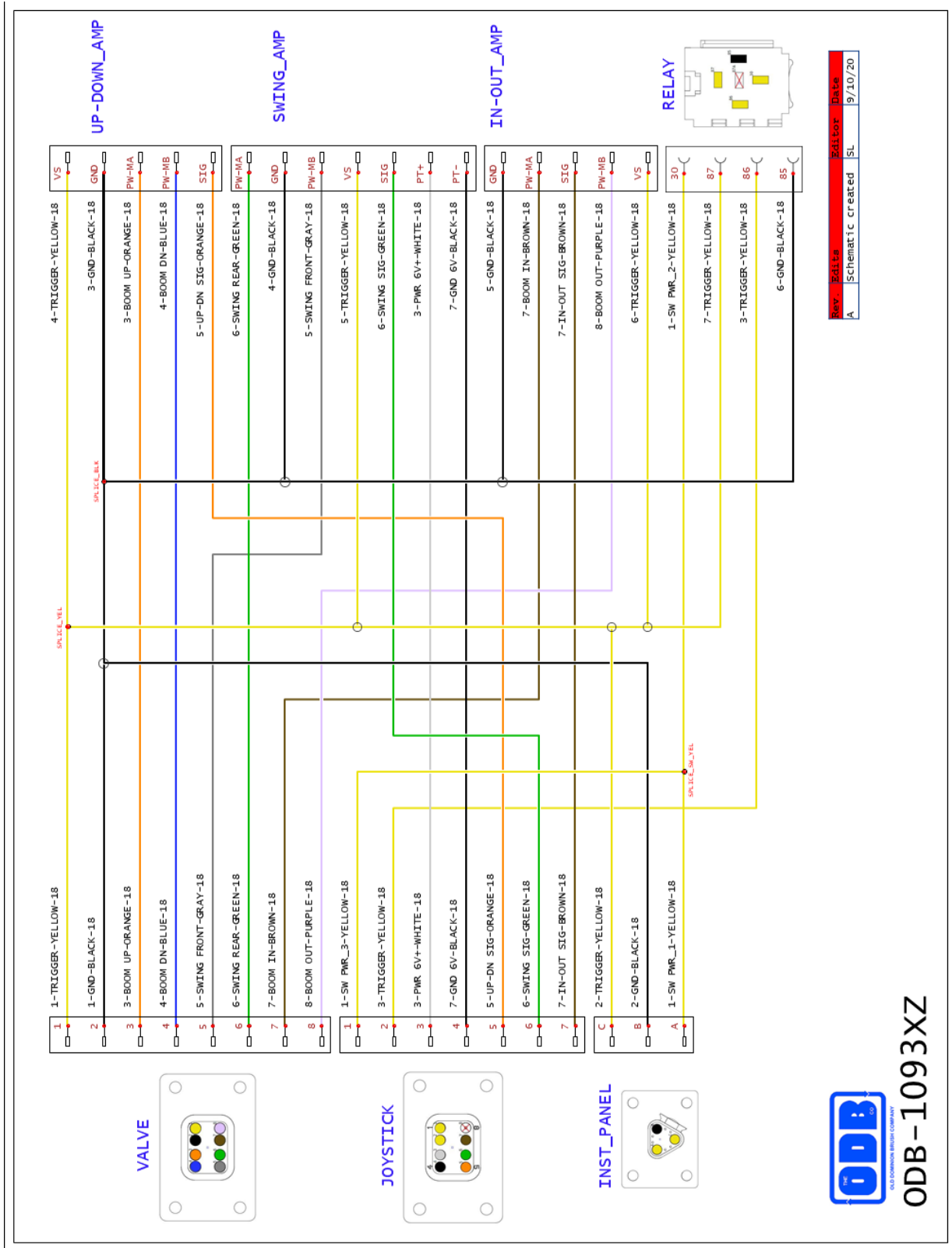

# Service Section

## 5.6 Electrical Schematic Cont. Engine Control Circuit Board

### TOP LAYER

The circuit board has traces on 2 layers - the top and bottom.

#### Main Plug Wire ID's

1	+ from Battery (Red)
2	Starter + (Red/Blue)
3	Fuel Sol./Col + (Orange)
4	Ground (Black)
5	Alt Energize + (Purple)
6	Oil Signal (White/Red)
7	Tach Signal (White)
8	E Stop Sig. (Tan/Black)
9	Insp. Door Sig. (Tan)
10	Fuel Level Sig. (Pink)
11	Temp Sig. (Blue)
12	Temp Shdwn Sig (Blue/Blk)
13	Oil Shutdown Sig. (Red/Blk)

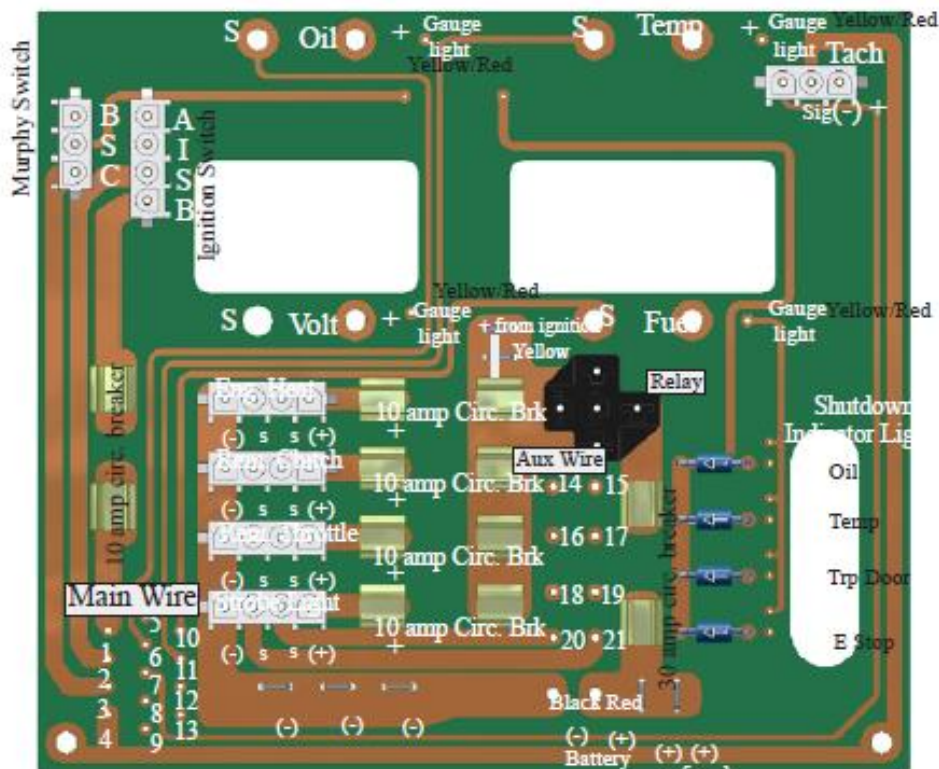

### BOTTOM LAYER (looking from the back)

#### Aux Plug Wire ID's

14	Eng Heat (+) (Yellow/Orange)
15	Eng. Heat Aux (Orange/Yellow)
16	Clutch Engage (Yellow/Green)
17	Clutch Disengage (Green/Yel)
18	Throttle Fast (Yellow/Blue)
19	Throttle Slow (Blue/Yellow)
20	Strobe Light + (Yellow/Purple)
21	Aux Light + (Purple/Yellow)

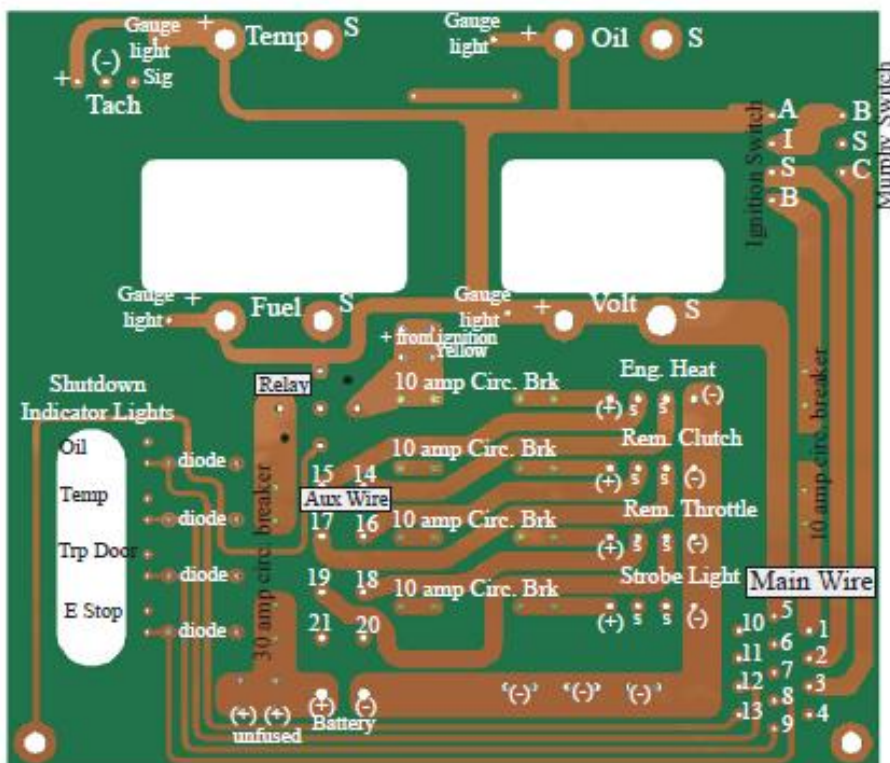

# Service Section

## 5.6 Electrical Schematic Cont.

### Main Harness Plug

Pin#	Description
1	Red + from battery
2	Red / Blue stripe - starter +
3	Orange - Fuel Sol/Col +
4	Black - Ground
5	Purple Alt Energize +
6	White / Red stripe Oil Signal
7	White - Tach Signal
8	Tan / Black stripe E Stop Sig.
9	Tan - Insp. Door Signal
10	Pink - Fuel Level Signal
11	Blue - Temp Signal
12	Blue/Black Temp Shtdwn Sig
13	Red/Black Oil Shutdown Sig.
14	Empty
15	Empty
16	Empty

### Aux. Harness Plug

Pin#	Description
1	Red + from battery
2	Yellow - Aux Plug harness
3	Yellow - Remote Throttle Har
4	Yellow / Orange stripe-Aux har
5	Orange / Yellow stripe-Aux har
6	Yellow / Green stripe-Clutch Eng
7	Empty
8	Green / Yellow stripe-Clutch Diseng
9	Yellow / Blue stripe-Throttle Fast
10	Empty
11	Blue / Yellow stripe-Throttle Slow
12	Yellow / Blue stripe-Strobe +
13	Purple / Yellow stripe-Strobe Sw+
14	Yellow - Aux Harness
15	Black - battery
16	Yellow - Aux Harness

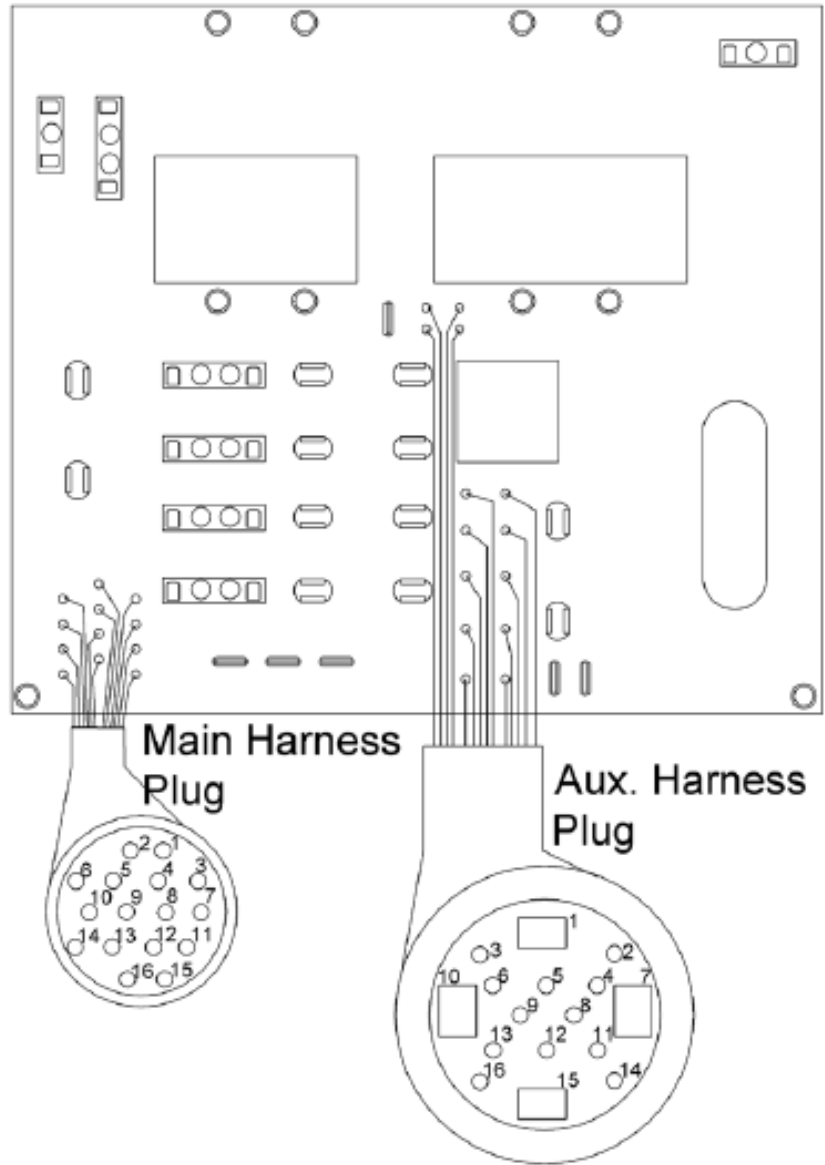



# **PARTS BREAKDOWN SECTIONS**

- 6.0 Engine Group**
- 7.0 Clutch Group**
- 8.0 Blower Housing Group**
- 9.0 Hydraulic Group**
- 10.0 Chassis and Hopper Group**
- 11.0 Hose Boom Group**

**PARTS BREAKDOWN SECTIONS**

**ODB COMPANY**  
5118 Glen Alden Drive  
Richmond, VA 23231  
**800-446-9823**



**6-0**

## **6.0 Engine Group**

**ENGINE GROUP**

**ODB COMPANY**  
5118 Glen Alden Drive  
Richmond, VA 23231  
**800-446-9823**

# 6.1 Engine Group

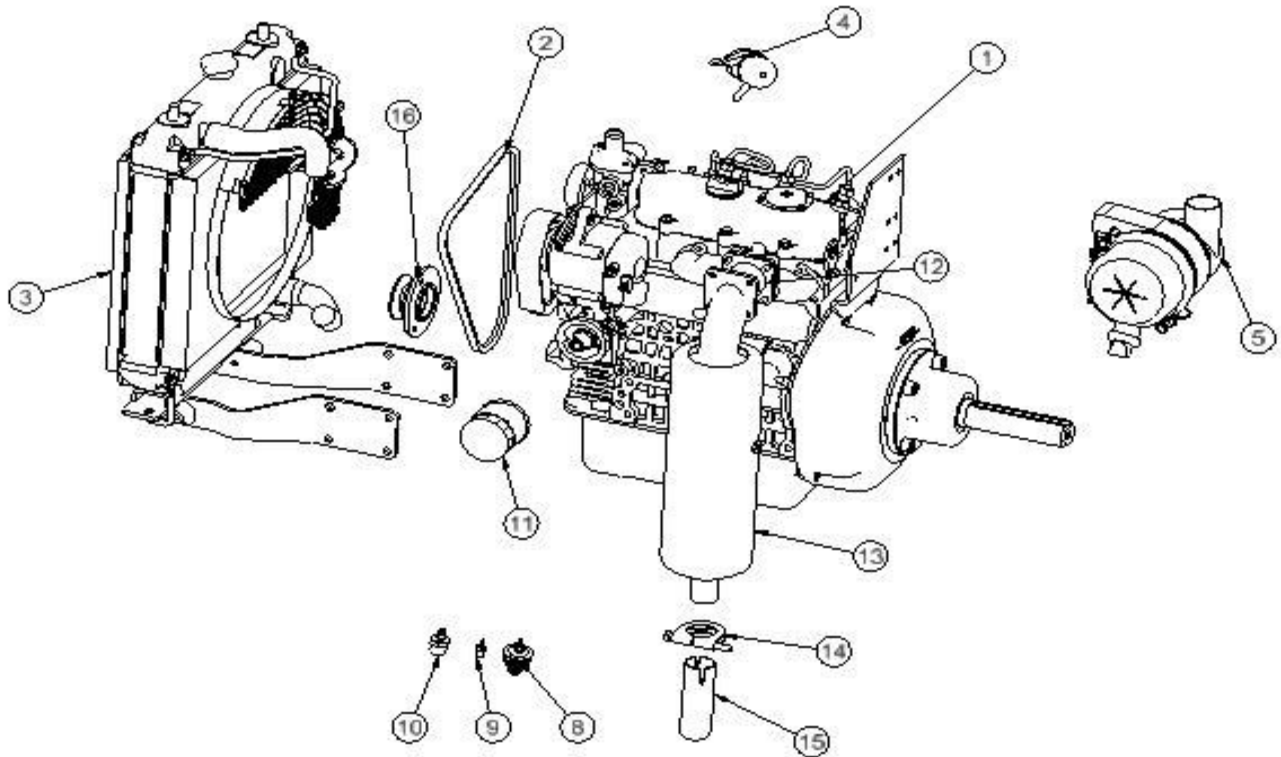

ITEM #	PART NO.	DESCRIPTION	ITEM #	PART NO.	DESCRIPTION
1	KUB25	Kubota 25HP Diesel	11	KUB.1209	Oil Filter
2	KUB.1217	<b>V Belt</b>	12	KUB.1220 KUB.1208	Exhaust Extension Gasket
3	KUB.1218	<b>Radiator Assembly</b>	12	KUB.1220	Exhaust Extension
4	KUB.1216	Solenoid	13	KUB.1208 KUB.1219	Gasket Muffler
5	KUB.1211	Air Filter	14	1419XZ	Muffler Clamp
8	KUB.1214	Oil Pressure Sender	15	1418XZ	Muffler Chrome Tip
9	KUB.1215	Temp Switch	16	1209XZ	Kubota Hyd.Pump Sheave
10	KUB.1213	Temp Sender	NS	KUB.120 0 KUB.121 0	Engine Harness Fuel Filter

## 6.2 Engine Mount Group

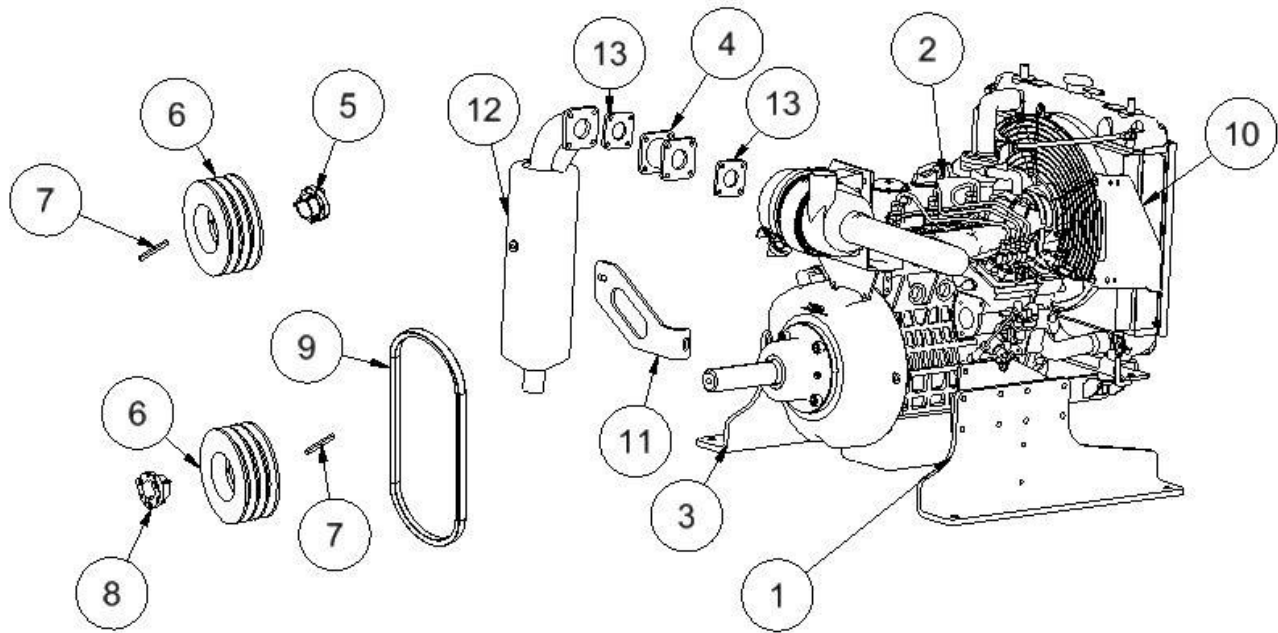

ITEM#	PART NO.	DESCRIPTION
1	897XZ	Motor Mount LH
2	KUB25	Kubota Diesel 25HP
3	898XZ	Motor Mount RH
4	KUB1220	Exhaust Pipe Extension
5	651403	Sheave Bushing Impeller
6	651402	6" Sheave
7	651005B	Impeller Key (2 per Machine)
8	651404BB	Sheave Bushing Engine
9	950XZ	V-Belt (3 per Machine)
10	1091XZ	Throttle Spring Retainer
11	1222XZ	Muffler Brace
12	KUB.1219	Muffler
13	KUB.1208.	Muffler Gasket (2 per Machine)
NS	9603273	Oil Switch



## 6.3 Electronic Throttle

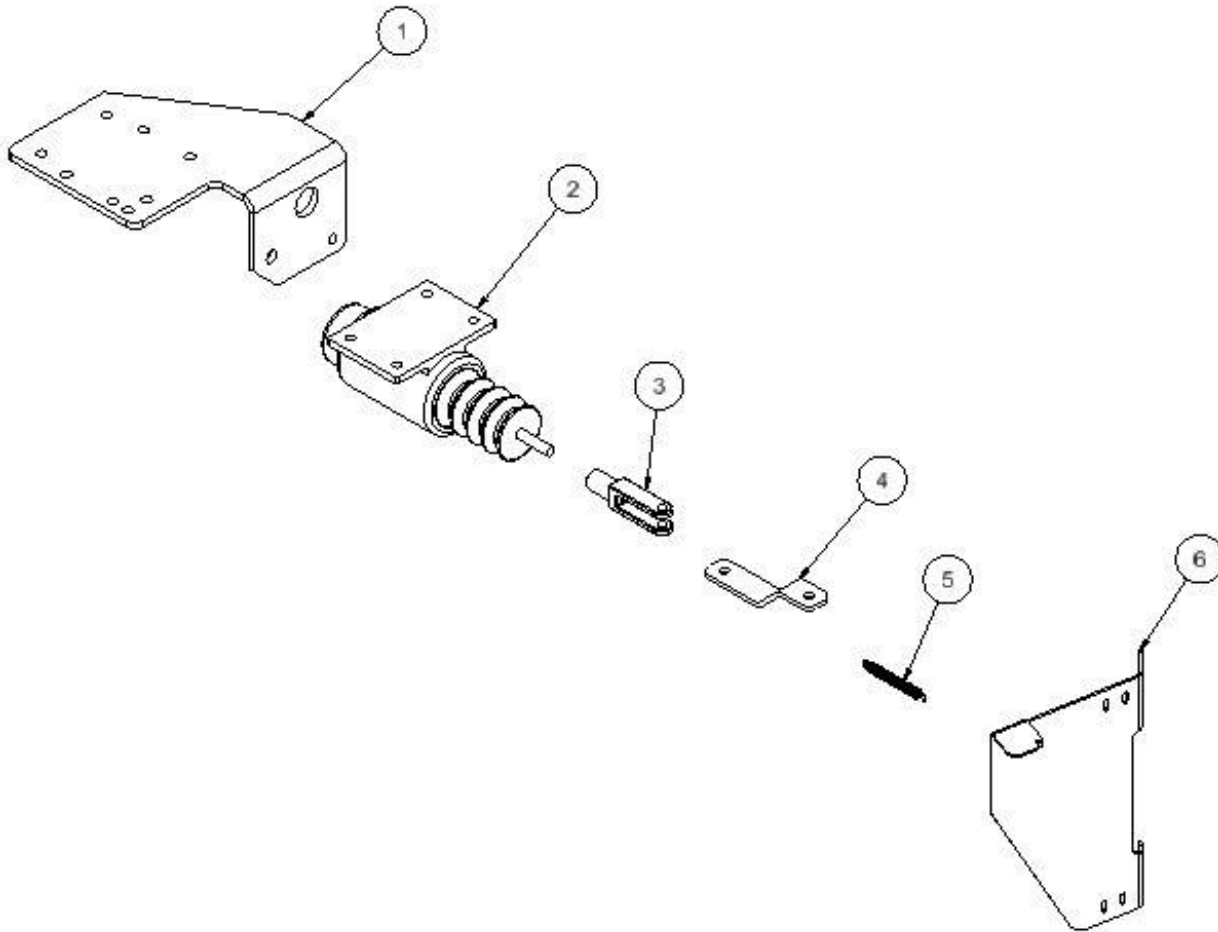

ITEM#	PART NO.	DESCRIPTION
1	1069XZ	Throttle Solenoid Bracket
2	1097XZ	Throttle Solenoid
3	1098XZ	Solenoid Yoke Assembly
4	1092XZ	Throttle Solenoid Linkage
5	1111XZ	Electronic Throttle Spring
6	1091XZ	Throttle Spring Retainer

## 6.4 Battery Group

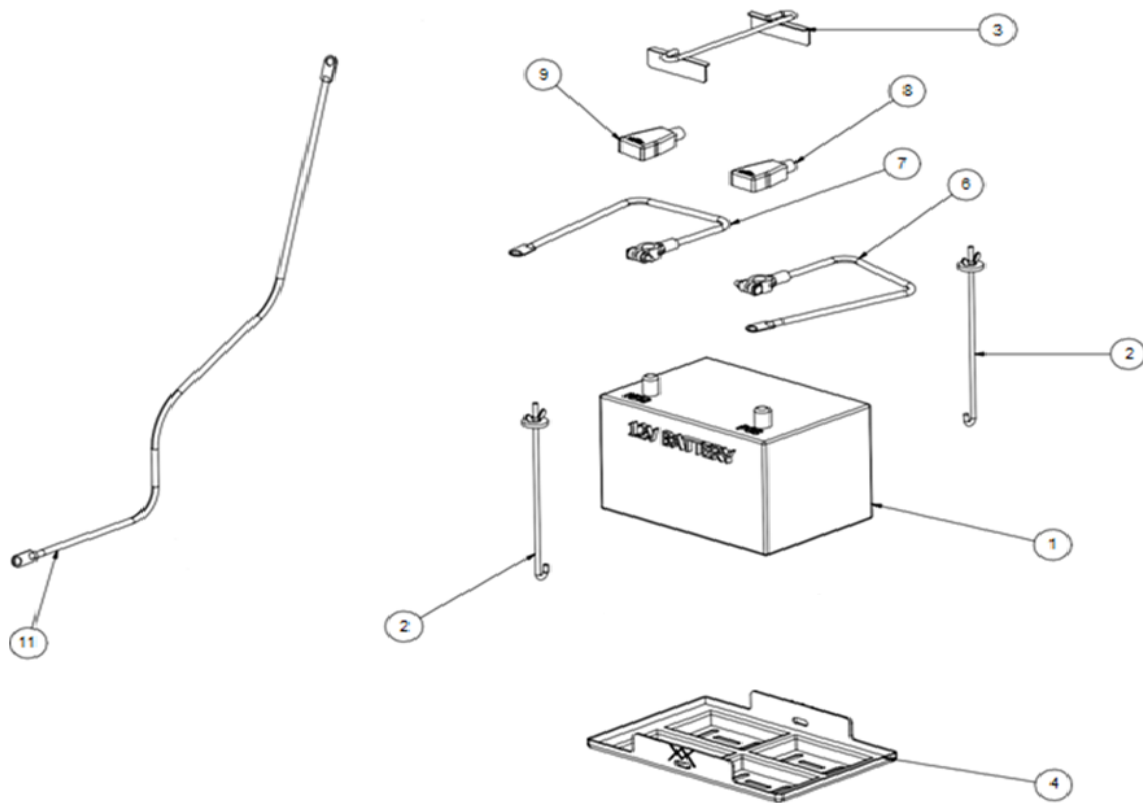

ITEM #	PART #	DESCRIPTION
1.	801300	Battery, not shippable
2.	BHB10J	J-Hook
3.	BHCB	Battery Hold Down Bar
4.	BTS1	Battery Tray
5.	BTSC1	Battery Tray, DCL
6.	LCT60084B	Positive Battery Cable, Battery to Solenoid - 84" Long
7.	LCT6015B	Negative Battery Cable, all - 15" long
8.	BTCR	Terminal Cover, Red, all
9.	BTC	Terminal Cover, Black, all
11.	LCT72B	Ground (Black) Cable to Engine, DCL500



**7-0**

## **7.0 Hydraulic/Electrical Group**

**Hydraulic/Electrical Group**

**ODB COMPANY**  
5118 Glen Alden Drive  
Richmond, VA 23231  
**800-446-9823**

# 7.1 Hydraulic Group

## DCL500 Hydraulic Hoses/Kits

<b>Part #</b>	<b>Qty</b>	<b>Description</b>	<b>Location Valve (B-Port Handle Side/A-Port Non-Handle Side)</b>
1102XZ 1169XZ	1	Up/Down Cylinder on Boom	Cylinder Rod End to Valve A Port Cylinder Cap End to Valve B Port
1103XZ 1170XZ	1	Left/Right Swing Motor on Boom	Swing Motor Inside Port ( <b>Closest to Skid</b> ) to Valve A Port Swing Motor Outside Port ( <b>Furthest from Skid</b> ) to Valve B Port
1104XZ 1171XZ	1	In/Out Cylinder on Boom	Cylinder Rod End to Valve A Port Cylinder Cap End to Valve B Port
1103XZ 1104XZ 808XZ	1	Pump-Pressure/Tank Valve 943XZ	(Both ports are labeled P - Pressure and T - Tank) Pressure Port on Valve to Pressure Port on Power Unit Tank Port on Valve to Tank Port on Power Unit
1301XZ	1	Hoist Up Pump 1293XZ	Pump 1293XZ To Hoist Cylinder Cap End
1302XZ	1	Hoist Down 1293XZ to Rod End	Hoist Cylinder Rod End to Pump 1293xz
1101XZ	1	Hyd Fittings Kit	Kit Includes all hydraulic fittings necessary for machine (Does not include 1136XZ Counter Balance Valve Kit)



## 7.1 Hydraulic Group Cont.

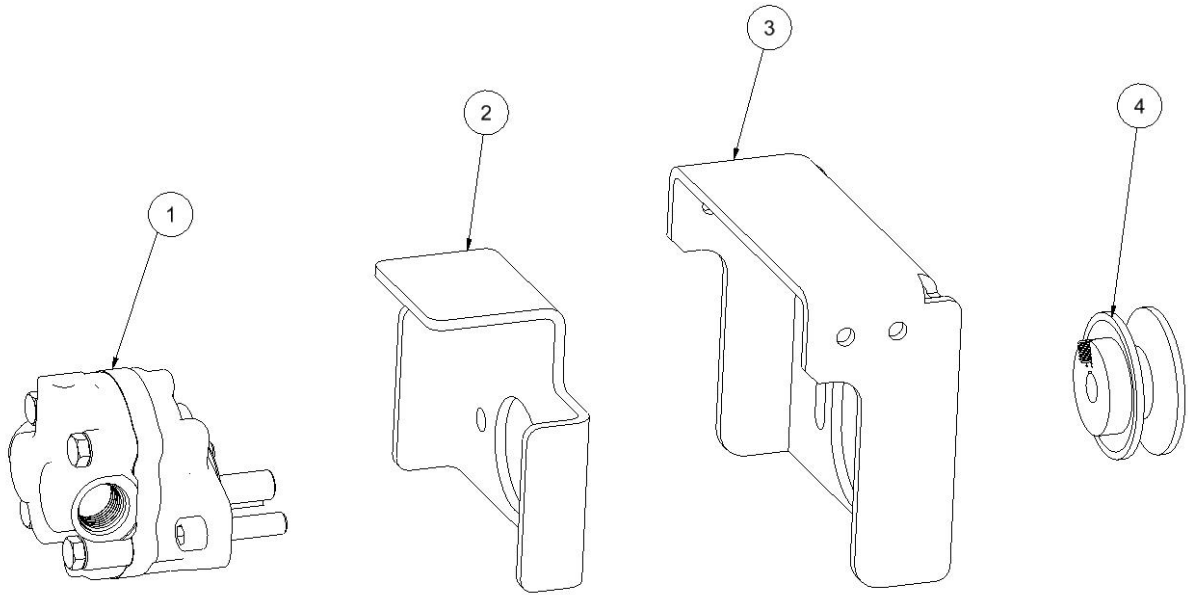

ITEM#	PART NO.	DESCRIPTION
1	1294XZ	PUMP
2	1212XZ	BRK,HYD,PUMP TAKEUP
3	1207XZ	BRK,HYD,PUMP MOUNT
4	1295XZ	HYD,PUMP PULLEY

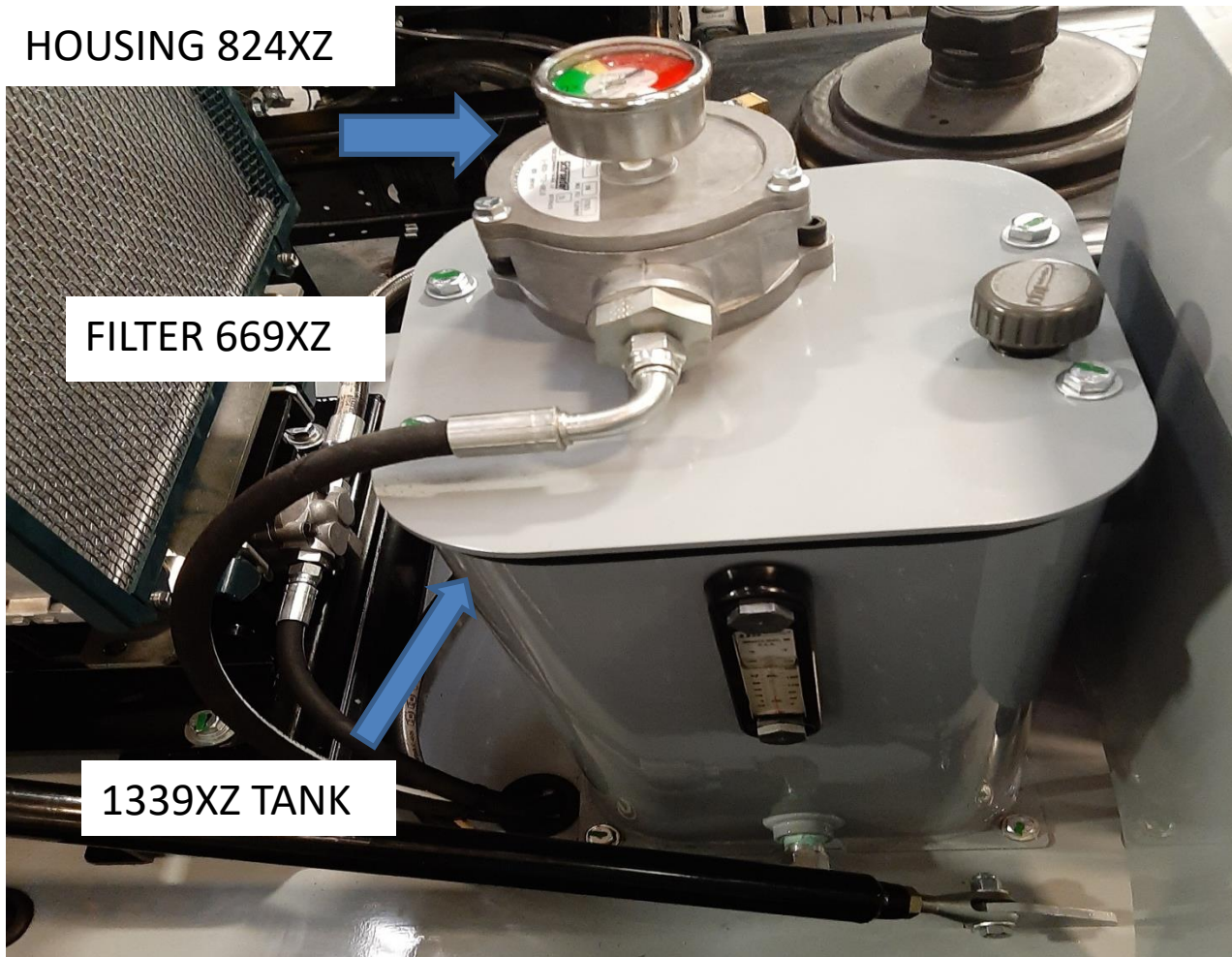
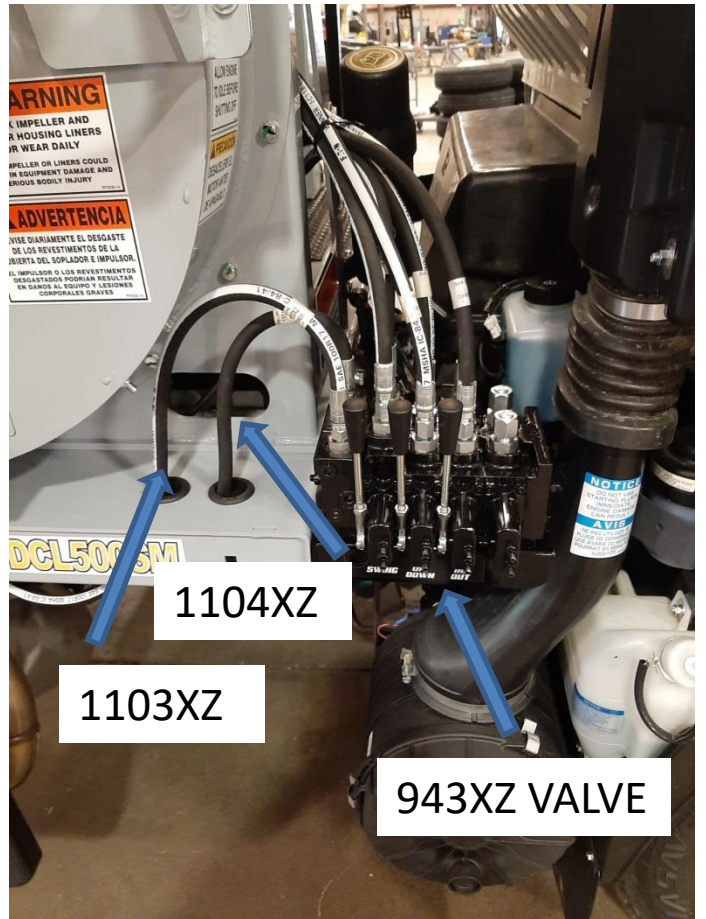

## 7.1 Hydraulic Group Cont.

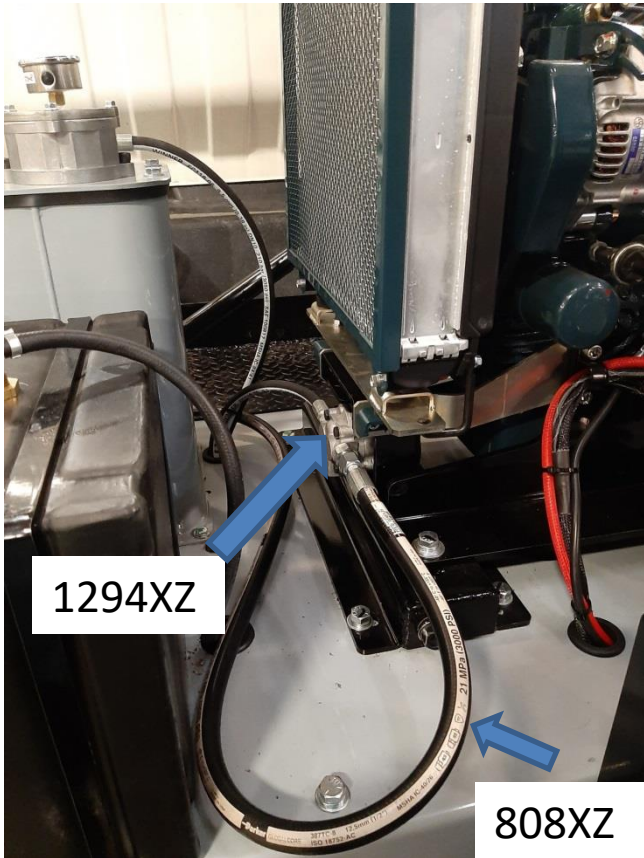

# 7.2 Electrical Group

<b>DCL500 Electrical Componets</b>		
<b><i>Part #</i></b>	<b><i>Qty</i></b>	<b><i>Description/Location</i></b>
1298XZ	1	Positive Battery Cable, from Pump to Positive Post on truck Battery
1299XZ	1	Negative Battery Cable, from Pump to Negative Post on tuck Battery
LCT60084B	1	Positive Battery Cable Kubota starter to battery
LCT6015B	1	Negative Cable Battery To Skid
LCT72B	1	Negative Cable Battery To Kubota
1086XZ	1	Valve Body Harness, from Valve Body to Amp Box
1087XZ	1	Joystick Jumper, from Joystick Box to Amp Box
1088XZ	1	Instrument Panel Harness, from Instrument Panel to Amp Box
8002501C	1	Center Marker Light Harness, connects center marker lights on bed to 8002608
8002608	1	Bed Harness Led Lights, main harness for all led lights on the bed.
954XZ	1	Push Button Switch, connects to pump to activate the pump for dump mode
SCL800WHLBF	1	Box Front Wire Harness, connects front box lights to front bed lights
SCL800WHLBR	1	Box Rear Wire Harness, connects rear box lights to rear bed lights
944XZ	1	Hud Diagnostics Tool
966XZ	1	Engine Harness, from engine to instrument panel
641051	2	Safety Shut Off Switch



## 7.2 Electrical Group Cont.



2018XZ



944XZ



LCT6015B

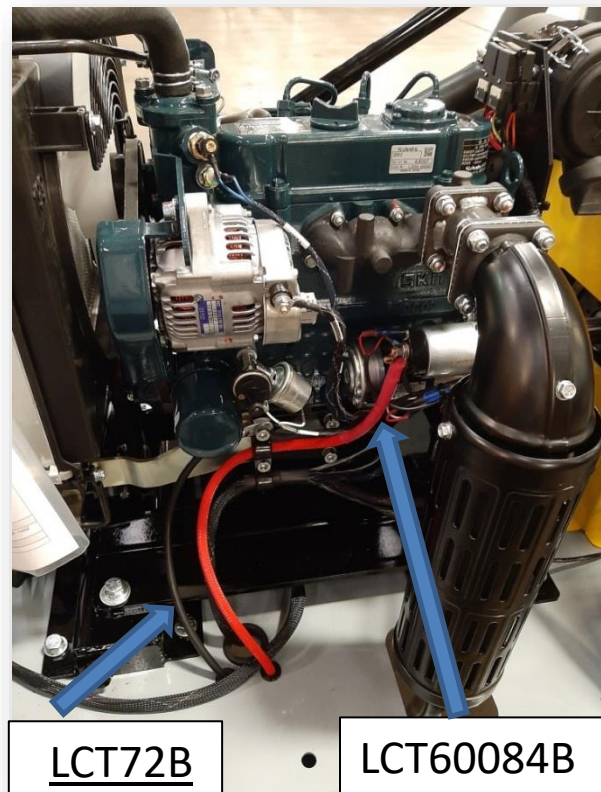

LCT72B

• LCT60084B

## 7.2 Electrical Group Cont.



## 7.2 Electrical Group Cont.



1298XZ

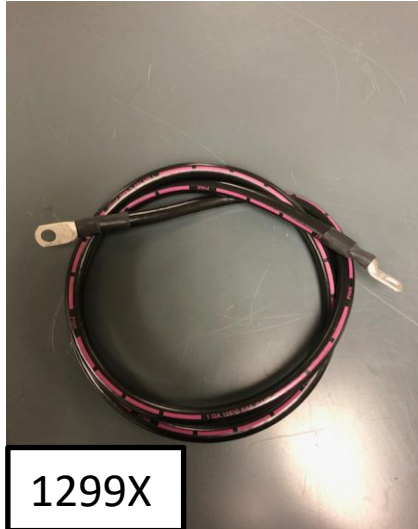

1299X

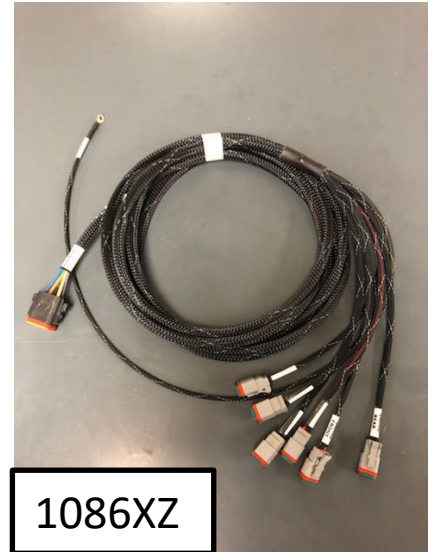

1086XZ

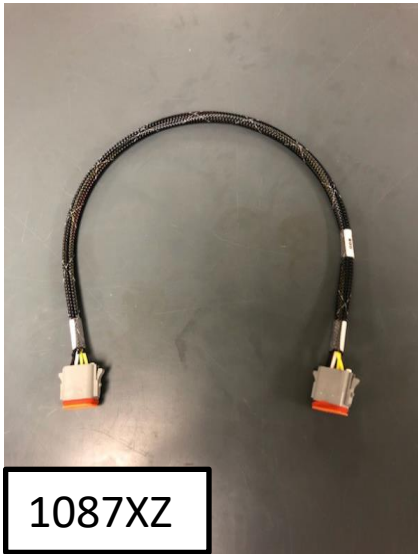

1087XZ



1088XZ



8002501C

# 7.2 Electrical Group Cont.

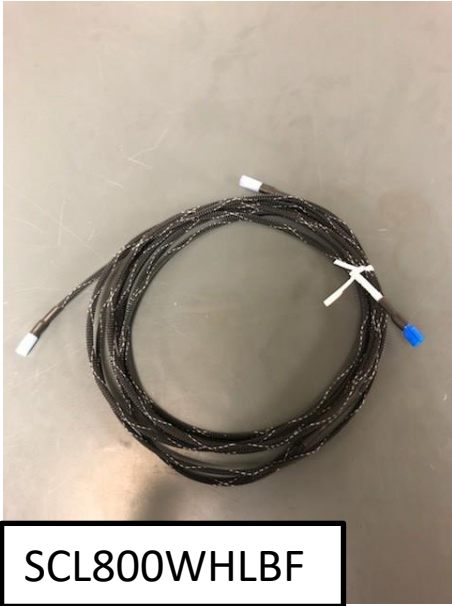
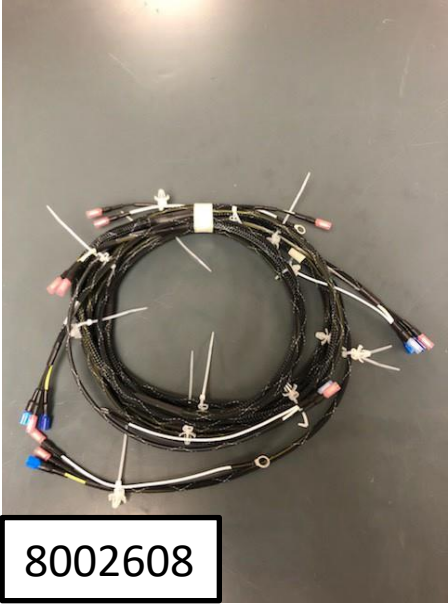

## 1086XZ

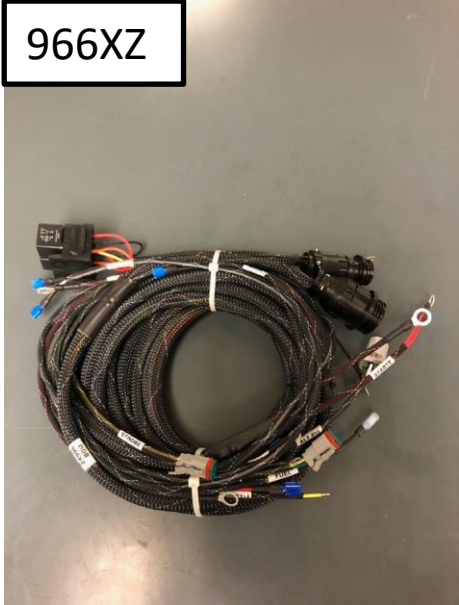
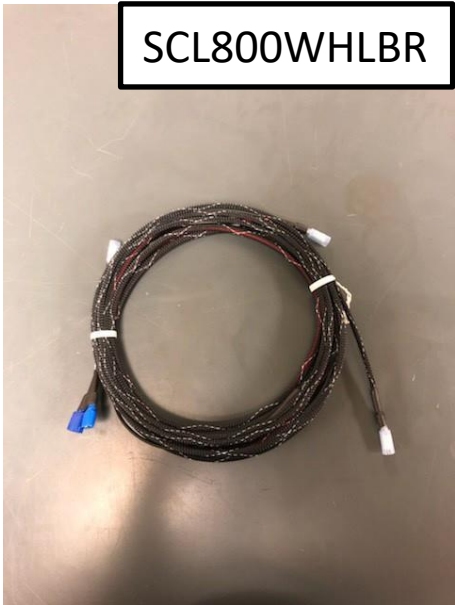



**8-0**

**8.0 SKID GROUP**

**8.0 Skid Group**

**SKID GROUP**

**ODB COMPANY**  
5118 Glen Alden Drive  
Richmond, VA 23231  
**800-446-9823**

## 8.1 Blower Housing Group

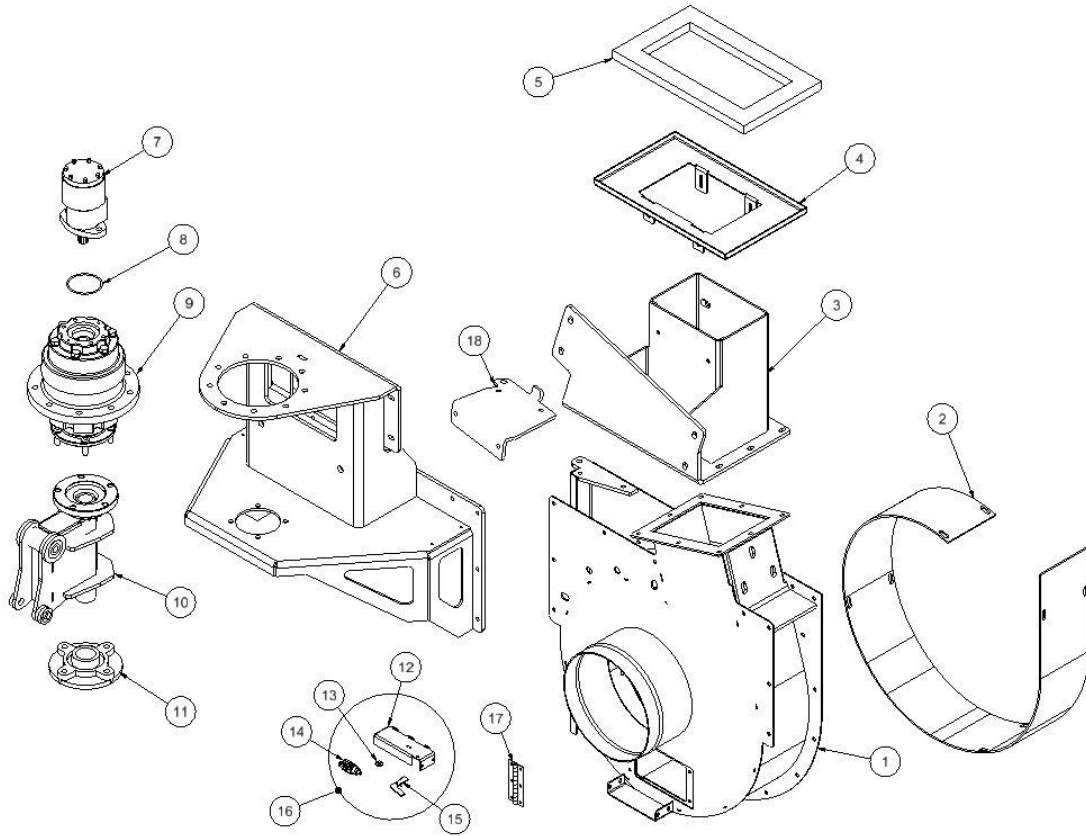

ITEM#	PART NO.	DESCRIPTION	ITEM#	PART NO.	DESCRIPTION
1	866XZ	Blower Assembly	10	264XZ	3X Knuckle
2	651002L	Blower Housing Liner	11	754XZ	Pilot Flange Bearing
3	868XZ	Exhaust Duct	12	STD4000	Limit Switch Box
4	801007	Exhaust Duct Flange	13	90295A450	Plastic Washer
5	801007G	Exhaust Duct Gasket	14	641051	Limit Switch
6	1001XZ	Auburn Blower Mount	15	STD4001	Limit Switch Actuator
7	800701C	Eaton Hyd Motor 3X	16	STD4000A	Limit Switch Assy
8	800701D	O Ring Seal	17	LCT621603	Clean Out Door Hinge
9	800704B	Auburn Gear Drive	18	1304XZ	Hinge Support

## 8.2 Skid Group

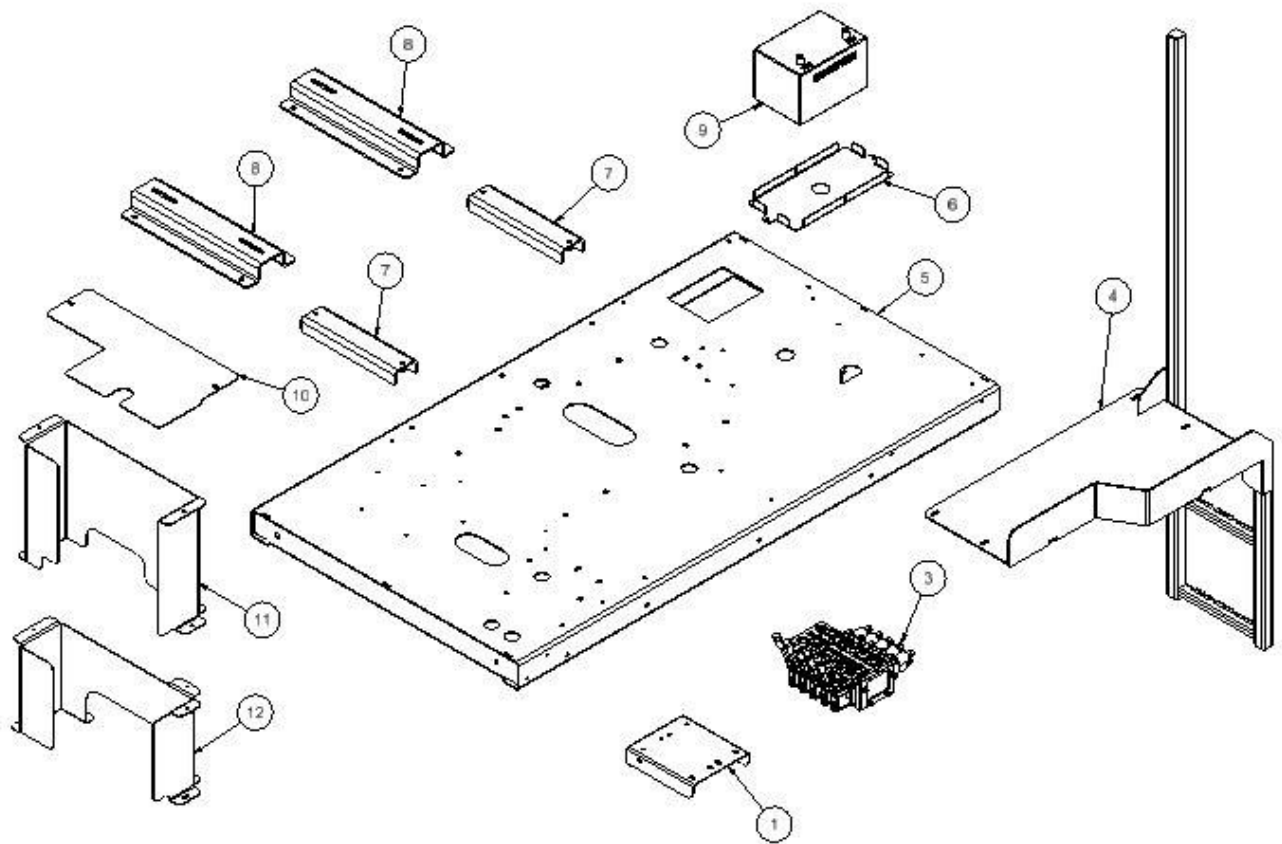

ITEM #	PART NUMBER	DESCRIPTION
1	890XZ	Hydraulic Valve Body Mount
3	943XZ	Hydraulic Valve Body
4	916XZ	Cat Walk
5	865XZ	Skid
6	801301	Battery Tray
7	896XZ	Adjustable Motor Mount Nut
8	895XZ	Adjustable Motor Mount
9	STD2200	Battery
10	1015XZ	Belt Guard Cover
11	1014XZ	Belt Guard Top
12	1013XZ	Belt Guard Bottom

## 8.3 Pedestal Group

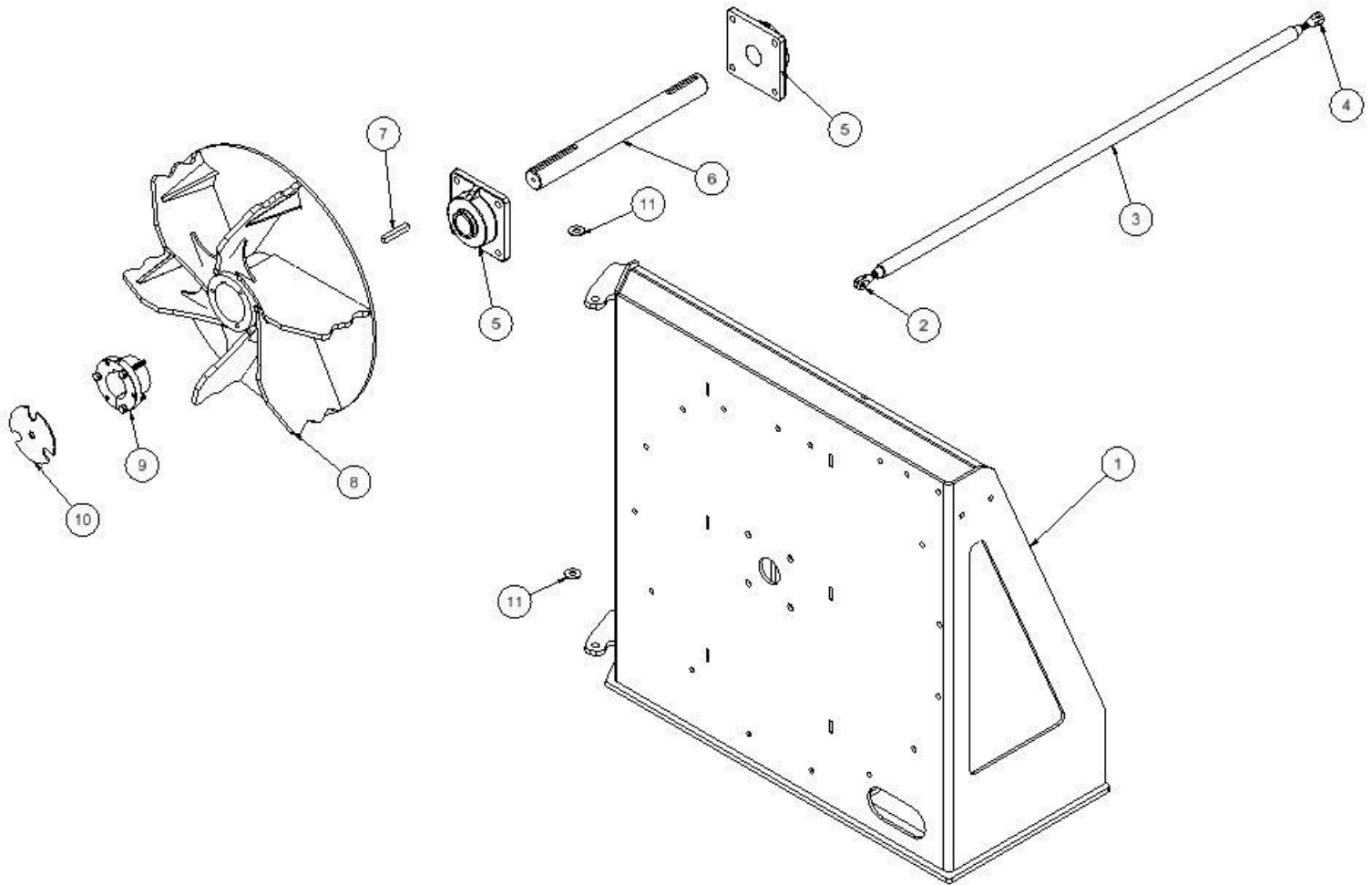

ITEM #	PART NUMBER	DESCRIPTION
1	1018XZ	Pedestal
2	956XZ	1/2" Clevis RH Threads
3	892XZ	Tie Rod Brace
4	957XZ	1/2" Clevis LH Threads
5	651406ODX	Bearing 4 Bolt Flange
6	651405B	Impeller Shaft
7	651005B	Impeller Key
8	651004C	20" Impeller
9	651403	Sheave Bushing Impeller
10	LCT600615	Shaft Protector
11	585XZ	Thrust Washer





**9-0**

## 9.0 Chassis and Hopper Group

**Chassis and Hopper Group**

**ODB COMPANY**  
5118 Glen Alden Drive  
Richmond, VA 23231  
**800-446-9823**

# 9.1 Fuel Tank Group

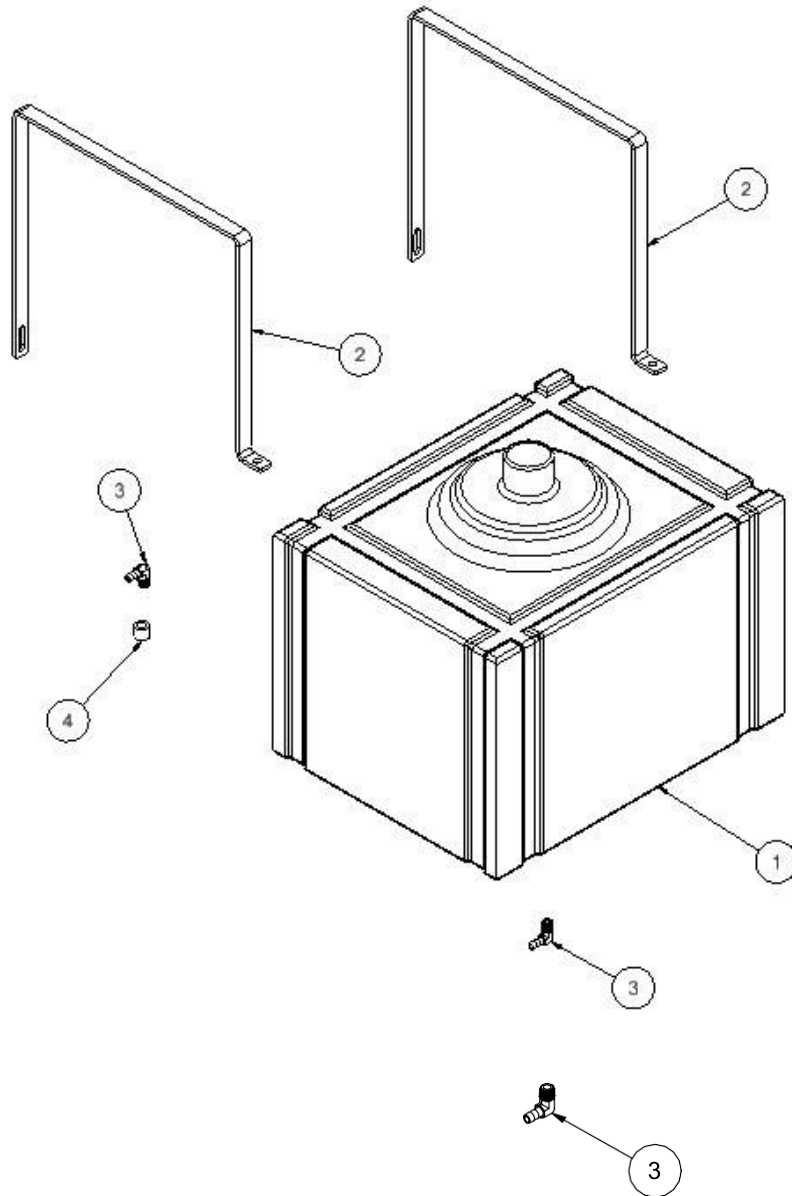

ITEM #	PART NUMBER	DESCRIPTION
1	8972	12 Gallon Fuel Tank
2	801106B	Fuel Tank Straps
3	HYF1047	Fuel Line Fitting Barbed
4	9744	Fuel Line Tank Fitting

# 9.2 Box Group

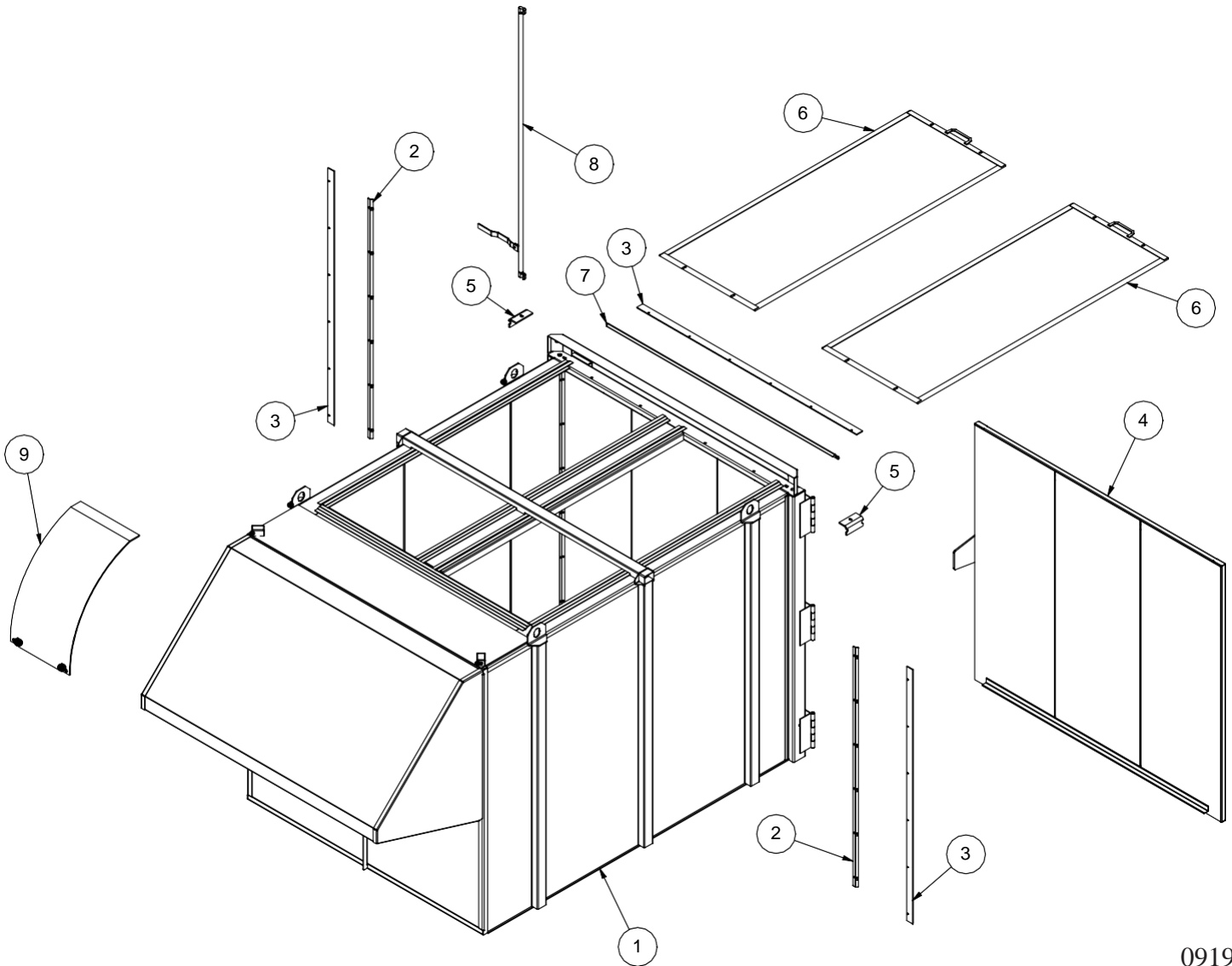

091913

ITEM #	PART NUMBER	DESCRIPTION
1	1036XZ	16YD Box
2	998XZ	Side Seal Retainer
3	1841XZ	Rubber Door Seal
4	993XZ	Side Hinge Door
5	SCL800036	Corner Clip Box
6	SCL805810 SCL805810P (Option)	STD Box Screen Perforated Box Screen
7	1020XZ	Top Seal Retainer
8	1010XZ	Door Rod
9	1035XZ	Deflector Plate

## 9.3 Chassis Group

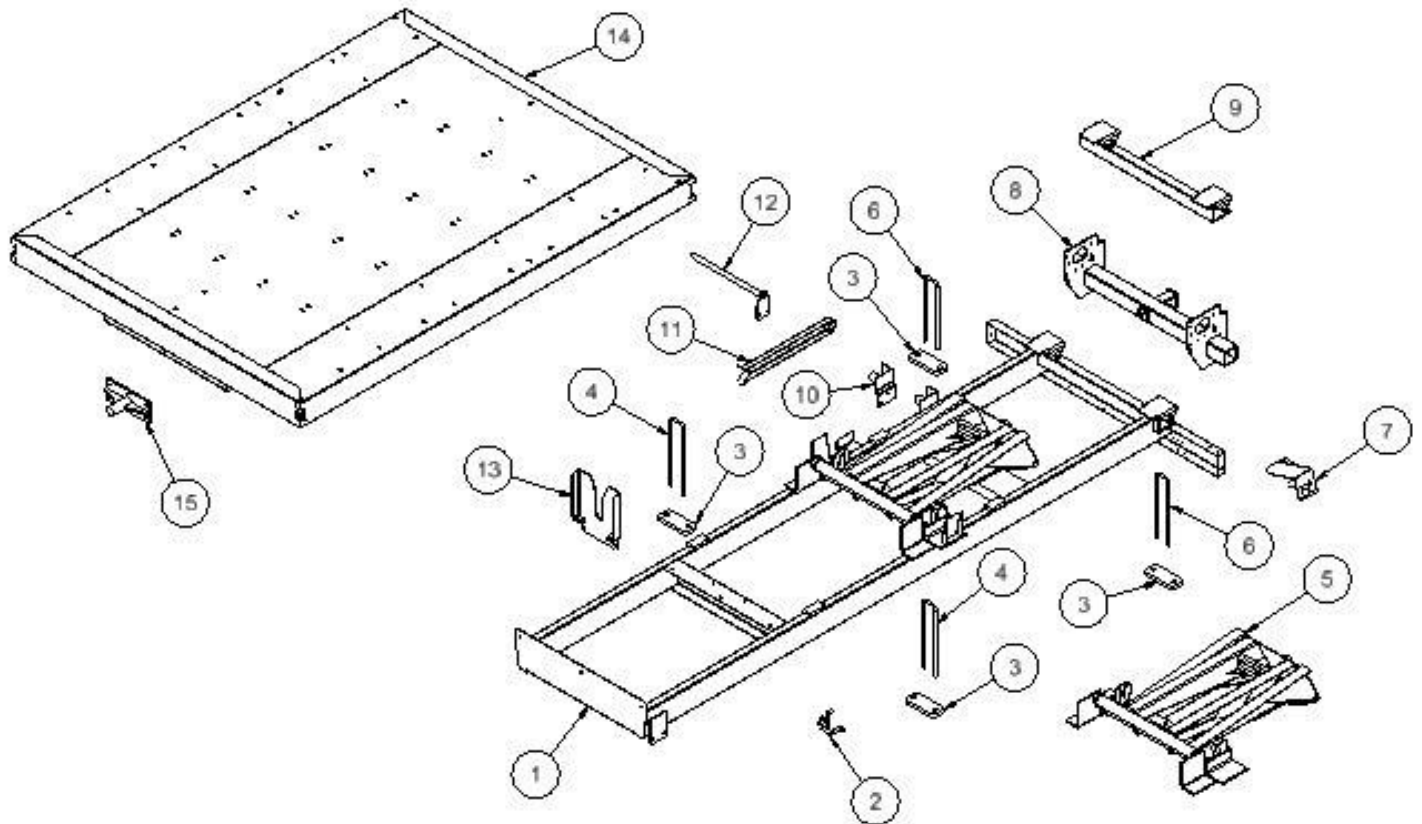

ITEM#	PART NO.	DESCRIPTION	ITEM#	PART NO.	DESCRIPTION
1	870XZ	DCL500 Chassis	9	106060ODX	Hinge Assembly
2	1077XZ	CBV Mounting Bracket	10	SCL800015B	Body Prop Receiver
3	899XZ	Chassis Plates	11	757XZ	Body Prop
4	955XZ	Chassis U-Bolts Long	12	758XZ	Body Prop Safety Handle
5	156994	Hoist	13	872XZ	Bed Guide
6	1078XZ	Chassis U-Bolts Short	14	871XZ	DCL500 Bed
7	915XZ	Fuel Neck Bracket	15	208XZ	Bed Guide Pin
8	1095XZ	Class 5 Hitch	NS	1138XZ	Mud Flap

# 9.4 Light and Reflector Group

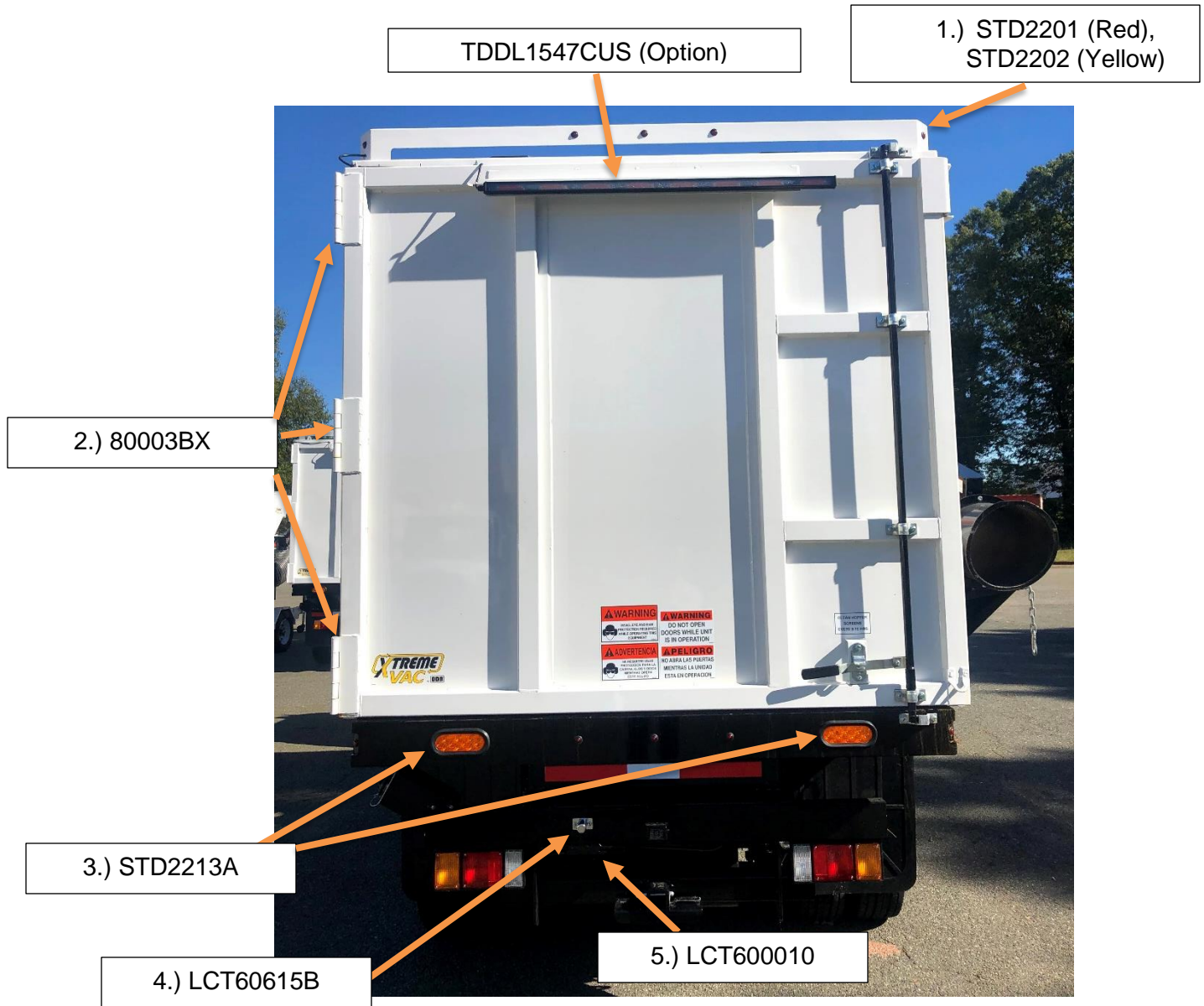

ITEM #	PART NUMBER	DESCRIPTION
1	STD2201 STD2202	LED Marker Light, Red-- rear of unit LED Marker Light, Yellow-- front of unit
2	80003BX	Door Hinge
3	STD2213A	LED Strobe Light with Flasher
4	LCT60615B	License Plate Light
5	LCT600010	License Plate Bracket

# 9.5 Backup Camera

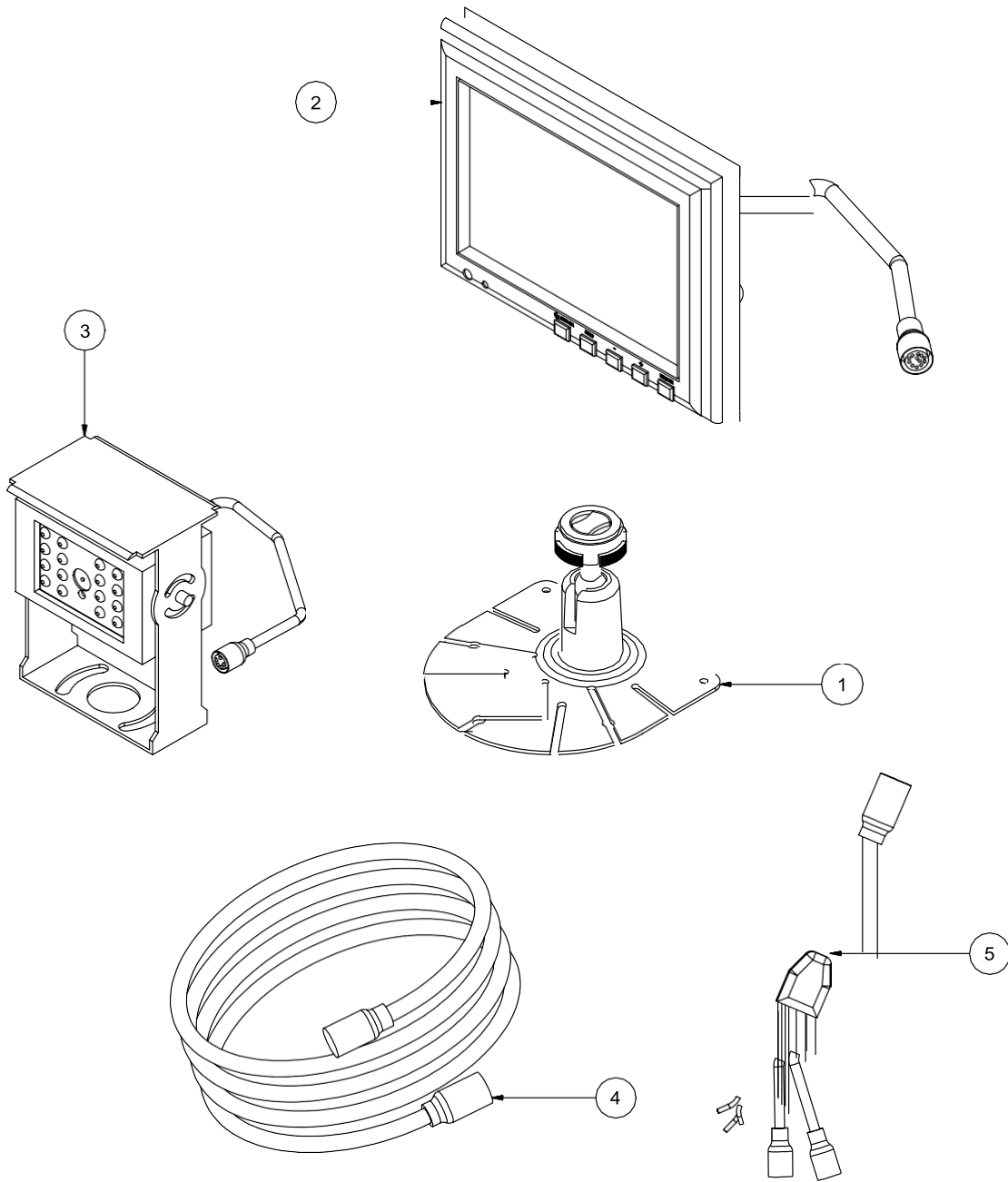

ITEM #	PART NUMBER	DESCRIPTION
*	UU56NTSC2	Complete Assembly
1		Monitor Mounting Bracket
2		LCD Monitor
3		Camera
4		Camera to monitor Harness
5		Input Wiring Harness



**10-0**

# 10.0 Hose Boom Group

**HOSE BOOM GROUP**

**ODB COMPANY**  
5118 Glen Alden Drive  
Richmond, VA 23231  
**800-446-9823**

# 10.1 Boom Group

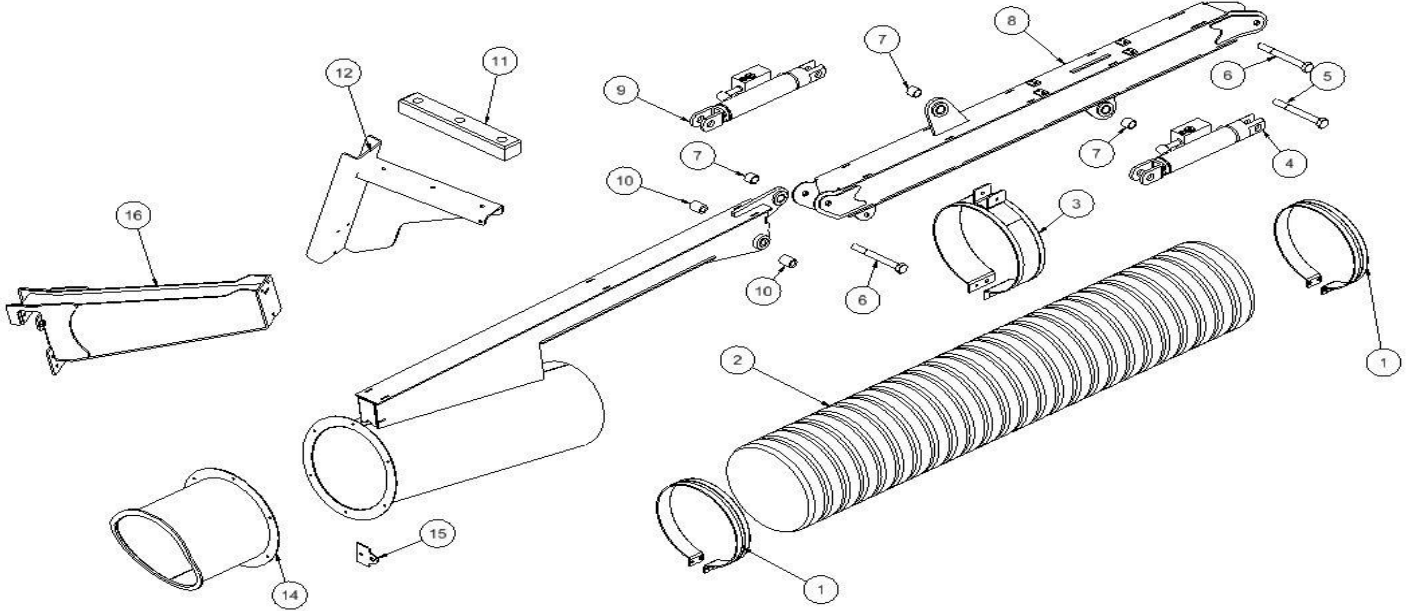

ITEM #	PART NUMBER	DESCRIPTION
1	651608	Clamp Band 12"
2	LCSDH12120	12" Standard Duty Hose
3	STD160512	Support Band 12"
4	356XZ	Up/Down Hydraulic Cylinder
5	800708	Bolt 3/4 X 4.5" Long
6	800710	Bolt 3/4 X 7" Long
7	584XZ	High Load Bushing
8	266XZ	Up/Down Boom Arm
9	610XZ	In/Out Hydraulic Cylinder
10	582XZ	Oil Embedded Bushing
11	945XZ	Hose Cradle Bumper
12	1226XZ	Hose Cradle
13	874XZ	In/Out Boom Arm w/Duct
14	875XZ	Multi Axis Nozzle
15	1019XZ	Nozzle Lock Tab
16	1225XZ	Hose Cradle Frame Mount Bracket



# 10.2 Cab Controls

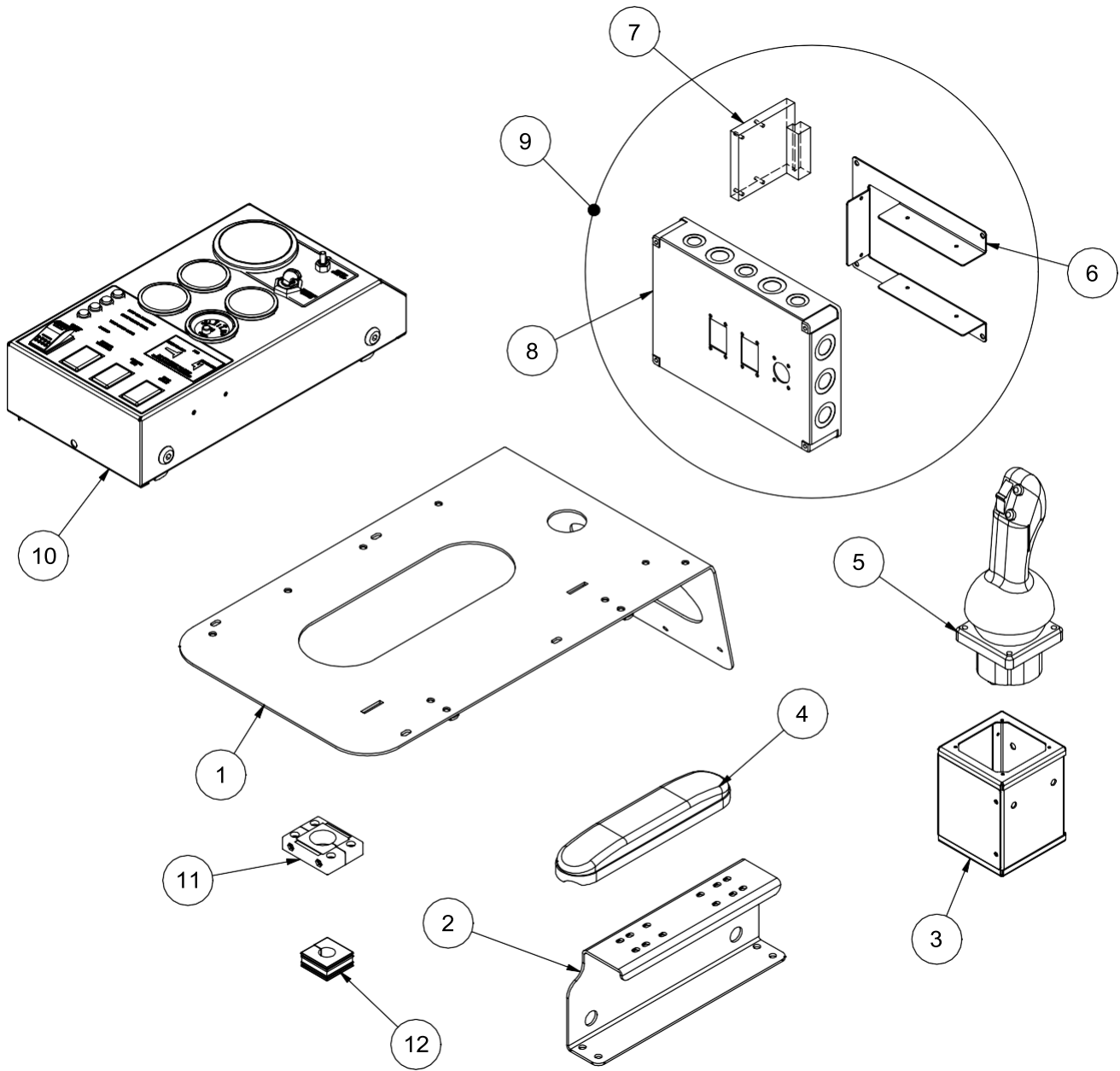

ITEM #	PART NUMBER	DESCRIPTION	ITEM #	PART NUMBER	DESCRIPTION
1	912XZ	Instrument Panel Mount	7	942XZ	Valve Driver
2	1084XZ	Arm Rest Bracket	8	1096XZ	Amp Box (No Holes)
3	914XZ	Joystick Box Mount	9	1093XZ	Amp Box Complete
4	1089XZ	Arm Rest	10	STD6300	STD Instrument Panel
5	941XZ	Controls Joystick	11	952XZ	Cord Grip Housing
6	901XZ	Amplifier Bracket	12	953XZ	Cord Grip Insert

# 10.3 Auburn Gear Drive

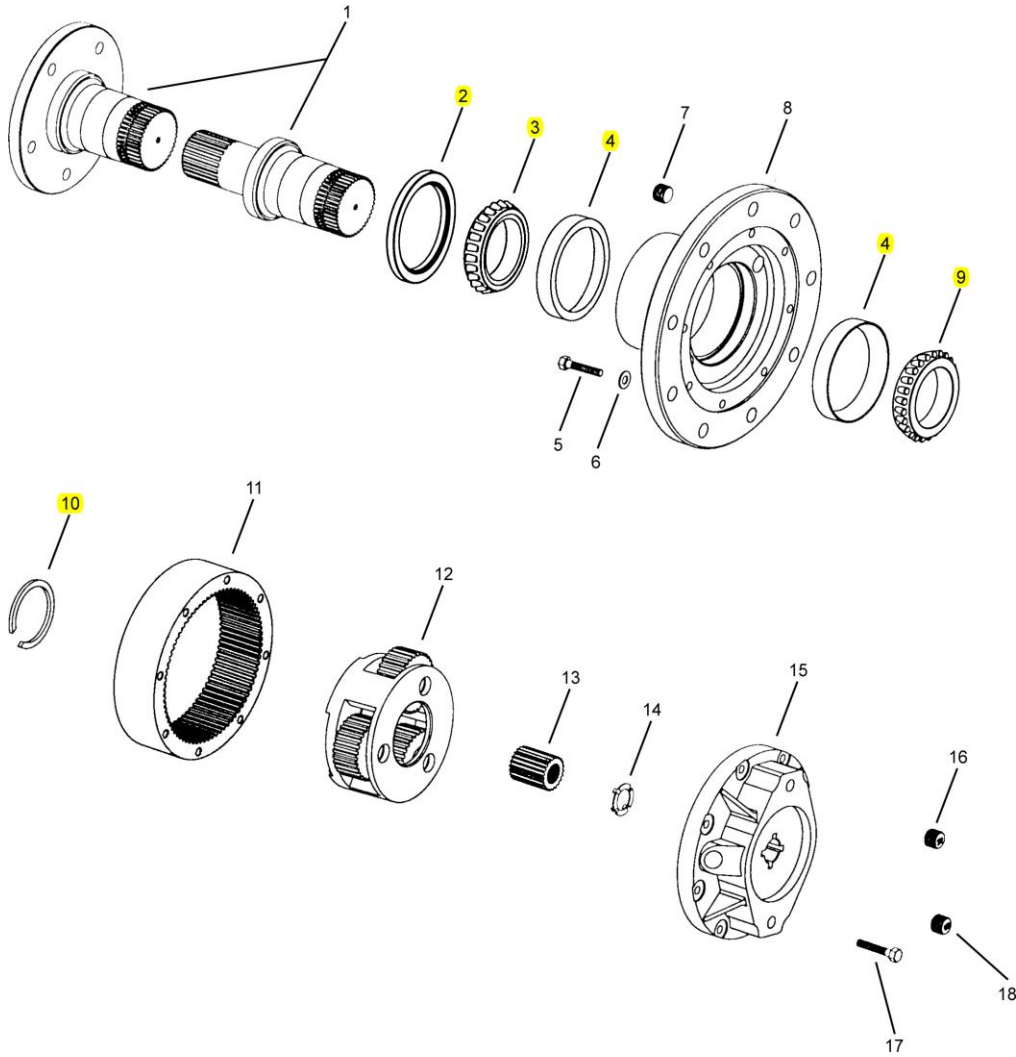

ITEM #	PART #	DESCRIPTION	ITEM #	PART #	DESCRIPTION
1		Output Shaft or Spindle	13		Sun Gear
2	14-00-044-010	Oil Seal	14		Thrust Washer
3	14-01-101-35	Bearing Cone	15		Cover
4	14-01-102-12	Bearing Cup	16	14-00-052-002	Magnetic Plug
5		Hex Head Bolt (grade 8)	17		Hex Head Bolt
6		Flat Washer	18	03-04-101-01	Pipe Plug
7	03-04-101-09	Pipe Plug	*	641008	Bearing and Seal Kit, includes #2,3,4,8 and 10
8		Hub	*	641017	Seal Kit, includes #2 & #10
9	04-01-101-17	Bearing Cone	*	618318 618318.N	Gear Bolt Nut
10	14-02-410-003	Retaining Ring Kit			
11		Ring Gear			
12		Carrier Assembly			

# Safety Section

## WARNING

Read and understand this entire manual before operating, maintaining or repairing the leaf vacuum.



# DANGER

## DO NOT RIDE, SIT OR STAND ON UNIT.

**RIDING ON UNIT  
COULD RESULT IN BODILY  
HARM OR FATAL INJURY  
USE EXTREME CAUTION WHEN  
UNIT IS IN USE, OR IN MOTION.**

If the decal above is missing or damaged call ODB immediately and we will send you a replacement free of charge. Never operate a unit with damaged or missing safety decals.

 DANGER

DO NOT RIDE, SIT OR STAND ON UNIT

 DANGER

DO NOT MODIFY THE UNIT FOR RIDERS IN ANY WAY. SERIOUS INJURY OR DEATH MAY OCCUR

ODB's leaf collectors are NEVER to be used to accommodate riders. If your unit has been modified to accommodate riders, remove these modifications immediately as this can result in serious injury or death.

 **CAUTION**

**DO NOT ATTEMPT TO OPERATE  
OR REPAIR  
THE LEAF COLLECTOR WITHOUT FIRST  
READING AND UNDERSTANDING THIS  
MANUAL**

IF YOU HAVE ANY QUESTIONS CONCERNING THE  
INSTALLATION OR OPERATION OF THIS UNIT, PLEASE CALL  
ODB FOR ASSISTANCE BEFORE ATTEMPTING TO REPAIR OR  
OPERATE THE UNIT.

**IMPROPER USE OF ANY MACHINE CAN  
RESULT IN SERIOUS INJURY!**

**STUDY AND FOLLOW ALL SAFETY  
PRECAUTIONS BEFORE OPERATING OR  
REPAIRING UNIT**

THIS MANUAL IS AN INTEGRAL PART OF THE LEAF COLLECTOR AND SHOULD  
BE KEPT WITH THE UNIT WHEN IT IS SOLD.

**ODB COMPANY**  
5118 Glen Alden Drive  
Richmond, VA 23231  
800-446-9823

