

LCT600

Belt Driven Leaf Collector



**Owner's Manual
Safety Manual
Pre-Operating Manual
Operating Manual
Maintenance Manual
Service Manual
Parts Catalog**

September 2015 edition

ODB Company
5118 Glen Alden Drive
Richmond, VA 23231
800-446-9823
www.leafcollector.com



LCT600

519201



CAUTION

**DO NOT ATTEMPT TO OPERATE
OR REPAIR
THE LEAF COLLECTOR WITHOUT FIRST
READING AND UNDERSTANDING THIS
MANUAL**

IF YOU HAVE ANY QUESTIONS CONCERNING THE
INSTALLATION OR OPERATION OF THIS UNIT, PLEASE CALL
ODB FOR ASSISTANCE BEFORE ATTEMPTING TO REPAIR OR
OPERATE THE UNIT.

**IMPROPER USE OF ANY MACHINE CAN
RESULT IN SERIOUS INJURY!**

**STUDY AND FOLLOW ALL SAFETY
PRECAUTIONS BEFORE OPERATING OR
REPAIRING UNIT**

THIS MANUAL IS AN INTEGRAL PART OF THE LEAF COLLECTOR AND SHOULD
BE KEPT WITH THE UNIT WHEN IT IS SOLD.

ODB COMPANY
5118 Glen Alden Drive
Richmond, VA 23231
800-446-9823



SAFETY PRECAUTIONS

⚠️ WARNING

Read and understand this entire manual before operating, maintaining or repairing the leaf vacuum.



⚠️ DANGER

DO NOT RIDE, SIT OR STAND ON UNIT.

**RIDING ON UNIT
COULD RESULT IN BODILY
HARM OR FATAL INJURY
USE EXTREME CAUTION WHEN
UNIT IS IN USE, OR IN MOTION.**

If the decal above is missing or damaged call ODB immediately and we will send you a replacement free of charge. Never operate a unit with damaged or missing safety decals.

⚠️ DANGER

DO NOT RIDE, SIT OR STAND ON UNIT

⚠️ DANGER

DO NOT MODIFY THE UNIT FOR RIDERS IN ANY WAY. SERIOUS INJURY OR DEATH MAY OCCUR

ODB's leaf collectors are NEVER to be used to accommodate riders. If your unit has been modified to accommodate riders, remove these modifications immediately as this can result in serious injury or death.

Municipal Products
Since 1910



Municipal Products
Since 1910

ODB COMPANY
5118 Glen Alden Drive
Richmond, VA 23231
800-446-9823
www.odbco.com or
www.leafcollector.com

THANK YOU

Thank you and Congratulations on your purchase of your ODB Leaf Collector. Your ODB leaf collector has been carefully designed and manufactured to give you a maximum amount of dependability and years of trouble-free operation. Take comfort in the fact the ODB has been manufacturing municipal products since 1910 and takes pride in our product's quality and our customer service.

Please take the time to thoroughly read this manual, as well as the engine manual, in its entirety before operating, maintaining, servicing or repairing your leaf collector. Please thoroughly review and follow all the safety procedures located in this manual.

Whenever you need replacement parts, service information or any question regarding your ODB product please feel free to contact us at 800-446-9823 or www.odbco.com.

Please record the following information for future reference:

Model No.:	_____
Serial No.:	_____
Vin No:	_____
Engine Serial No.:	_____
Date of Purchase:	_____

TABLE OF CONTENTS



WARNING Read and understand this entire manual before operating, maintaining or repairing the leaf vacuum.

Table of Contents

Contents

LCT600

Table of Contents

1.0 GENERAL SAFETY

1.1 Safety Symbol Definitions	10
1.2 Do's and Do Not's:.....	11
1.3 Training:.....	13
1.4 Safety Decals	14
1.5 VIN And Serial Number Locations.....	16

2.0 PRE-OPERATING SECTION

2.1 Instrument and Controls:	18
2.2 Safe Operations:.....	20
2.3 Preparation For Operation.....	22
2.4 Pre-Transport Checks.....	23
2.5 Personal Protective Equipment and Clothing	25
2.6 Work Site Preparation	26

3.0 OPERATING SECTION

3.1 Starting Engine.....	28
3.2 Engaging the PTO.....	30
3.3 Fluid Drive Coupler (if equipped)	32
3.4 Vacuuming Leaves	33

4.0 MAINTENANCE SECTION

4.1 Maintenance Overview:.....	35
4.2 Maintenance and Lubrication	36
4.3 Lubrication:.....	37
4.4 Preventative Maintenance	40
4.5 Torque Values.....	44

5.0 SERVICE SECTION

5.1 Engine Electrical Troubleshooting Guide.....	48
5.2 Auto Mfg. Clutch Adjustment - 2008 and after	49
5.3 Hydraulic Boom Troubleshooting Guide.....	50
5.4 Impeller Installation and Removal.....	51
5.4 Impeller Installation and Removal, continued.....	52
5.5 Belt Adjustment and Replacement Guide	53
5.6 Flange Bearing Installation and Removal.....	54
5.6 Flange Bearing Installation and Removal.....	55
5.7 Replacing the Blower Housing Liners.....	56
5.7 Replacing the Blower Housing Liners; continued,.....	57

5.10 WIRING DIAGRAMS

5.10.1 Engine Wiring Diagram	59
------------------------------------	----

TABLE OF CONTENTS



WARNING

Read and understand this entire manual before operating, maintaining or repairing the leaf vacuum.

5.10.2 Engine Main Harness - Enlarged	60
5.10.3 Auxillary Engine Harness - Enlarged.....	61
5.10.4 Engine Wiring Harness Descriptions.....	62
5.10.4 Engine Wiring Harness Descriptions, continued	63
5.10.5 Engine Rocker Switch Wiring Diagrams	64
5.10.6 Main Circuit Board	65
5.10.7 Main Circuit Board Plug Diagrams	66
5.10.8 Trailer Plug Wiring Diagram	67
5.10.9 Trailer Wiring Harness	68
5.10.10 Brake Wiring Harness	69
5.10.11 Boom Wiring Diagram.....	70
5.10.12 Remote Throttle / Clutch Wiring Harness	71
5.20.1 Wiring Harness Diagram 2 Section Valve Body - 2 Axis	72
5.20.2 Wiring Harness Diagram 4 Section Valve Body - 3 Axis	73
6.0 ENGINE GROUP	
6-0	75
6.1 Instrument Panel Group	76
6.2 Air Cleaner Group.....	77
6.3 Strobe Light Parts Group	78
6.4 Sheet Metal Group	79
6.5 Engine Mount Group	80
6.6 Muffler (Exhaust) Assembly.....	81
6.7 Radiator Assembly Group.....	82
6.8 Engine Senders / Switch Group	83
6.9 John Deere Common Engine Parts Group.....	84
6.10 Battery Group.....	85
6.11 Engine Miscellaneous Parts Group.....	86
6.12 Remote Clutch / Throttle Circuit Board Assembly.....	87
6.13 Remote Clutch and Remote Throttle Assembly.....	88
6.14 Chaffe Eliminator Assembly, hinged	89
7.0 CLUTCH GROUP	
7-0	90
7.1 AutoHD PTO Clutch Group.....	91
7.2 AutoHD PTO Assembly Group	92
7.3 AutoHD PTO Linkage Group	93
7.4 Clutch Assist Group.....	94
7.5 Kraft Fluid Drive Group (Optional).....	95
7.6 Kraft Fluid Drive Installation (Optional).....	96
7.7 Kraft Fluid Drive Breakdown (Optional)	97
7.8 Kraft Fluid Drive Common Parts (Optional).....	98
8.0 BLOWER HOUSING GROUP	

TABLE OF CONTENTS



WARNING Read and understand this entire manual before operating, maintaining or repairing the leaf vacuum.

8-0	99
8.1 Blower Housing Group	100
8.2 Blower Housing Face Group - LCT600.....	101
8.3 Belt Drive Assembly	102
8.4 Pedestal Group.....	103
8.5 Exhaust Duct Assembly	104
9.0 TRAILER GROUP	
9-0	105
9.1 Trailer Bed Group	106
9.2 Fuel Tank Group	107
9.3 Tongue Group	108
9.4 Hydraulic Parking Jack - OPTIONAL.....	109
9.4 Axle Hub Assembly	110
9.5 Brake Assembly	111
9.6 Hydraulic Surge Brake Actuator - OPTIONAL.....	112
10.0 HOSE BOOM GROUP	
10-0	113
10.1 Boom Group.....	114
10.2 Intake Hose Group.....	115
10.3 M3219 Hydraulic Boom Pump.....	116
10.4 Curb Nozzle Assembly- OPTIONAL	117
MULTI-AXIS BOOM SECTION (OPTIONAL)	
11-0	118
11.1 (2 or 3X) Hydraulic Tank - Valve Body Group.....	119
11.2 Joystick Group - 2 Axis Boom.....	120
11.3 (2 Axis) Boom Assembly	121
11.4 (3 Axis) Boom Assembly	122
11.5 Hinged Boom Frame Assembly	123
11.6 Auburn Gear Drive Assembly - 3 Axis	124
11.7 2 Section Valve Body	125
11.8 4 Section Valve Body.....	126
INDEX	
Index	128

SAFETY PRECAUTIONS

WARNING

Read and understand this entire manual before operating, maintaining or repairing the leaf vacuum.



DANGER

DO NOT RIDE, SIT OR STAND ON UNIT.

**RIDING ON UNIT
COULD RESULT IN BODILY
HARM OR FATAL INJURY
USE EXTREME CAUTION WHEN
UNIT IS IN USE, OR IN MOTION.**

If the decal above is missing or damaged call ODB immediately and we will send you a replacement free of charge. Never operate a unit with damaged or missing safety decals.

 DANGER

DO NOT RIDE, SIT OR STAND ON UNIT

 DANGER

DO NOT MODIFY THE UNIT FOR RIDERS IN ANY WAY. SERIOUS INJURY OR DEATH MAY OCCUR

ODB's leaf collectors are NEVER to be used to accommodate riders. If your unit has been modified to accommodate riders, remove these modifications immediately as this can result in serious injury or death.

SAFETY PRECAUTIONS

WARNING

Read and understand this entire manual before operating, maintaining or repairing the leaf vacuum.

1.0 GENERAL SAFETY

1.0 GENERAL SAFETY

Contents

LCT600

Table of Contents

1.0 GENERAL SAFETY

1.1 Safety Symbol Definitions	10
1.2 Do's and Do Not's:.....	11
1.3 Training:.....	13
1.4 Safety Decals	14
1.5 VIN And Serial Number Locations.....	16

SAFETY PRECAUTIONS





WARNING

Read and understand this entire manual before operating, maintaining or repairing the leaf vacuum.

1.1 Safety Symbol Definitions

This manual provides the owners/operator with procedures for safe operation, maintenance and repair of your leaf collector. As with any machine, there are hazards associated with their operation. For this reason safety is emphasized throughout this manual. To highlight specific safety information the following safety definitions are provided to assist the reader.

The purpose of safety symbols are to attract your attention to possible dangers. The safety symbols, and their explanations, deserve your careful attention and understanding. The safety warnings do not by themselves eliminate any danger. The instructions or warnings they give are not substitutes for proper accident prevention measures.

SYMBOL	MEANING
	SAFETY ALERT SYMBOL: Indicates danger, warning or caution. Attention is required in order to avoid serious personal injury. May be used in conjunction with other symbols or pictographs.
 DANGER	Disregarding this safety warning WILL result in serious equipment damage, injury or possible death.
 WARNING	Disregarding this safety warning CAN result in serious equipment damage, injury or possible death.
 CAUTION	Disregarding this safety warning MAY result in minor or moderate injury or property damage.

SAFETY PRECAUTIONS

WARNING

Read and understand this entire manual before operating, maintaining or repairing the leaf vacuum.

1.2 Do's and Do Not's:

This section contains some general safety precautions to do and not to do. This is not an all inclusive list and it is the responsibility of the operator to have proper training and use common sense in work situations.

WARNING

DO NOT:

1. **DO NOT** operate, maintain or repair this unit without having fully read and understood ALL the aspects of this manual.
2. **DO NOT** ride, sit or stand on unit at anytime.
3. **DO NOT** modify the leaf vacuum for any reasons to allow for riders.
4. **DO NOT** operate the unit in a state of disrepair.
5. **DO NOT** operate the unit with ANY guards or safety devices broken, missing, or inoperable.
6. **DO NOT** operate the unit without wearing proper safety equipment.
7. **DO NOT** operate this unit while under the influence of any alcohol or medication.
8. **DO NOT** operate this unit if you have a record of mental instability or dizziness which could result in injury to yourself or others.
9. **DO NOT** operate this unit if you are under 18 years of age.
10. **DO NOT** operate this unit without fully inspecting the unit for any damage or leakage.
11. **DO NOT** operate if the unit has any excessive vibration.
12. **DO NOT** operate unit with the inspection door limit switch damaged or missing.
13. **DO NOT** operate unit unless it is properly connected to a leaf collection box.
14. **DO NOT** operate unit unless it is properly attached to the tow vehicle.
15. **DO NOT** tow unit without using all the safety chains.
16. **DO NOT** tow unit with a damaged tongue.
17. **DO NOT** fill fuel tank with engine running. Allow engine to cool for 5 minutes before refueling.
18. **DO NOT** operate unit if fuel is spilled or with fuel cap off.
19. **DO NOT** smoke or weld near the unit.
20. **DO NOT** run engine in an enclosed area.
21. **DO NOT** place hands or feet near moving or rotating parts.
22. **DO NOT** operate engine with an accumulation of grass, leaves or other debris on the engine.

SAFETY PRECAUTIONS

WARNING

Do Not, continued;

- 23. **DO NOT** run engine with air cleaner removed.
- 24. **DO NOT** leave leaf machine unattended while in operation.
- 25. **DO NOT** park machine on steep grade or slope.
- 26. **DO NOT** vacuum a leaf pile without looking for foreign objects such as metal, glass, plastic or large pieces of wood.

Do's:

WARNING

- 1. **DO** completely read and understand the owner's manual before operating, maintaining or repairing the leaf collector.
- 2. **DO** follow engine and PTO manufacturer operating and maintenance instructions.
- 3. **DO** check fuel lines and fittings frequently for cracks or leaks. Replace if necessary.
- 4. **DO** completely inspect the unit before leaving the service garage.
- 5. **DO** check the tow tongue each day for cracks.
- 6. **DO** inspect and be attentive to what is being vacuumed.
- 7. **DO** check the impeller, liners and blower housing for cracks or holes daily.
- 8. **DO** wear proper safety equipment as described in this manual.
- 9. **DO** watch for pedestrians, animals and other foreign material when vacuuming leaves.
- 10. **DO** replace any worn or missing safety stickers immediately.

SAFETY PRECAUTIONS

1.3 Training:

WARNING

Improper use of the ODB leaf collector CAN result in severe personal injury or death. All personnel using this leaf vacuum must be trained and qualified with all the operations, maintenance, repair and safety procedures defined in this manual.

The warnings and procedures regarding safety in this manual are to be used as a guideline only. It is impossible to cover all the events that could happen in the vacuuming process. For this reason, it is vital that the owner accept the responsibility to implement a training program that will provide every operator or mechanic the basic skills and knowledge to make good judgement in all situations.

This training program must include the entire scope of hazards, precautions and government regulations encountered in the vacuuming process. The program should stress the need for regularly scheduled preventive maintenance and detailed equipment safety checks.

It is strongly recommended that all training programs be documented to ensure all operators and mechanics receive initial training on not just the operation but the safety features of the leaf collector.

SAFETY PRECAUTIONS

1.4 Safety Decals

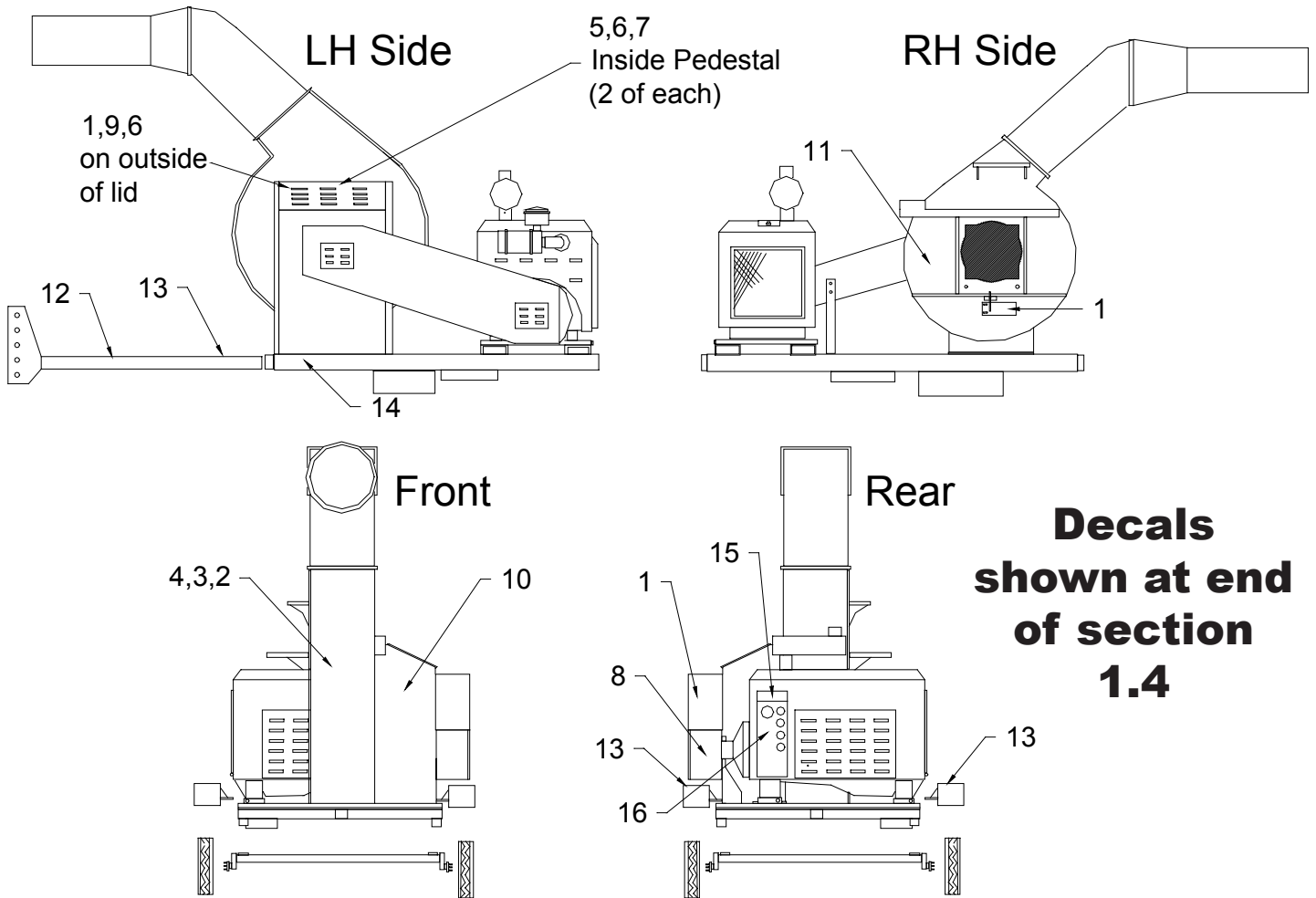

ITEM NO.	PART NUMBER	DESCRIPTION
*	LCT600DK	Decal Kit
1.	200182	Danger--Do Not Open Cover While in Operation
2.	200179	Danger--Do Not Ride, Sit or Stand on Unit
3.	200181	Danger--Head, Eye and Ear Protection Required
4.	200221	LCT600 Leaf Collector sticker
5.	200109	Do Not Over-Lubricate bearings
6.	200055	Use Diesel Only
7.	200177	Danger--Flammable
8.	200059	Do Not Engage PTO over 1,000 RPM
9.	200183	Danger--Rotating Parts
10.	200178	Danger--Explosion Hazard
11.	200189	Danger--Check Impeller and Liners Daily for Wear
12.	200180	Danger--Inspect Tow Bar for Damage
13.	200104	Warning--Check Lug nuts
14.	200061	ODB leaf collection systems sticker
15.	200120	Throttle decal
16.	200223	Control Panel Decals (Safety Shut Off/Switches)

SAFETY PRECAUTIONS

1.4 Safety Decals - Decal Layout for LCT60C/600/650/6000

1

⚠ WARNING

DO NOT OPEN COVER WHILE IN OPERATION



2

⚠ DANGER

DO NOT RIDE, SIT OR STAND ON UNIT.

RIDING ON UNIT COULD RESULT IN BODILY HARM OR FATAL INJURY. USE EXTREME CAUTION WHEN UNIT IS IN USE, OR IN MOTION.



3

⚠ WARNING

HEAD, EYE AND EAR PROTECTION REQUIRED WHILE OPERATING THIS EQUIPMENT



5

DO NOT OVER-LUBRICATE

BEARINGS SHOULD BE LUBRICATED EVERY 10-15 HOURS OF OPERATION WITH 2 OZ. (ABOUT 2 STROKES OF AVERAGE GREASE GUN) OF APPROVED LUBRICANT. USE THE ENGINE HOUR METER AS A REFERENCE. SEE YOUR OWNER'S MANUAL.

6

USE DIESEL ONLY

7

⚠ WARNING

FLAMMABLE



8

ON SAFETY LIGHT OFF

DO NOT: START OR STOP ENGINE WITHOUT DISENGAGING PTO. ENGAGE CLUTCH WITH ENGINE RUNNING OVER 1000 RPM.

DO: ENGAGE SLOWLY TO PREVENT ENGINE STALLING.

← DISENGAGE ENGAGE →

FAILURE TO FOLLOW THESE INSTRUCTIONS MAY RESULT IN PTO FAILURE.

9

⚠ WARNING

ROTATING PARTS

- BEFORE OPERATING READ OPERATORS MANUAL FOR OPERATING AND SAFETY INSTRUCTIONS.
- DO NOT OPERATE WITH ANY GUARDS OR COMPONENT PARTS REMOVED FROM UNIT.
- BEFORE MAKING ANY ADJUSTMENTS OR REPAIRS STOP ENGINE AND REMOVE SPARK PLUG WIRE.
- WHILE IN OPERATION KEEP ALL PARTS OF BODY AWAY FROM INTAKE AND EXHAUST SECTIONS.
- WHEN OPERATING MACHINE KEEP PEOPLE AND PETS A SAFE DISTANCE AWAY.



10

⚠ DANGER

EXPLOSION HAZARD

DO NOT CUT, BURN OR WELD WITHOUT FIRST REMOVING OR COMPLETELY PURGING THE FUEL TANK

CONSULT OWNERS MANUAL.



11

⚠ WARNING

CHECK IMPELLER AND BLOWER HOUSING LINERS FOR WEAR DAILY

WORN IMPELLER OR LINERS COULD RESULT IN EQUIPMENT DAMAGE AND SERIOUS BODILY INJURY

12

⚠ DANGER

REMOVE TOW BAR AND CHECK THE MOUNTING HOLES FOR CRACKS AND/OR WEAR BEFORE THE MACHINE IS PUT IN SERVICE EVERY SEASON. VISUALLY INSPECT THE TOW BAR DAILY FOR DAMAGE. IF THE TOW BAR IS BENT, DO NOT TOW MACHINE. REPLACE TOW BAR. DO NOT TOW MACHINE UNLESS ALL SAFETY CHAINS ARE PROPERLY INSTALLED AND IN GOOD OPERATING CONDITION. FAILURE TO DO SO MAY RESULT IN BODILY HARM OR FATAL INJURY.



13

WARNING

DRIVER CHECK WHEEL LUGS BEFORE MOVING THIS VEHICLE.

FAILURE TO DO SO MAY RESULT IN BODILY HARM OR FATAL INJURY!

14

ODB LEAF COLLECTION SYSTEMS

Richmond, Virginia

15

THROTTLE



16



SAFETY PRECAUTIONS

1.5 VIN And Serial Number Locations

⚠ WARNING

Thoroughly read and understand the safety and pre-operating sections of this manual before starting the engine.

⚠ WARNING

Make sure each operator knows and understands the load ratings of the towed vehicle and that he/she is qualified to tow the vehicle.

figure 1.5a



The serial number tag and Vehicle Identification Number (VIN) sticker is located in front of the unit to the right of the the tongue. (See figure 1.5a).

The VIN sticker gives the user critical information regarding the trailer specifications such as Gross Vehicle Weight Rating (GVWR) which is the maximum allowable total weight of the fully loaded trailer, including liquids, cargo and the tongue weight of any towed vehicle, the GAWR or Gross Axle Weight Rating which is the maximum allowable weight the axles are designed to carry. The tire inflation pressure is also on the sticker.

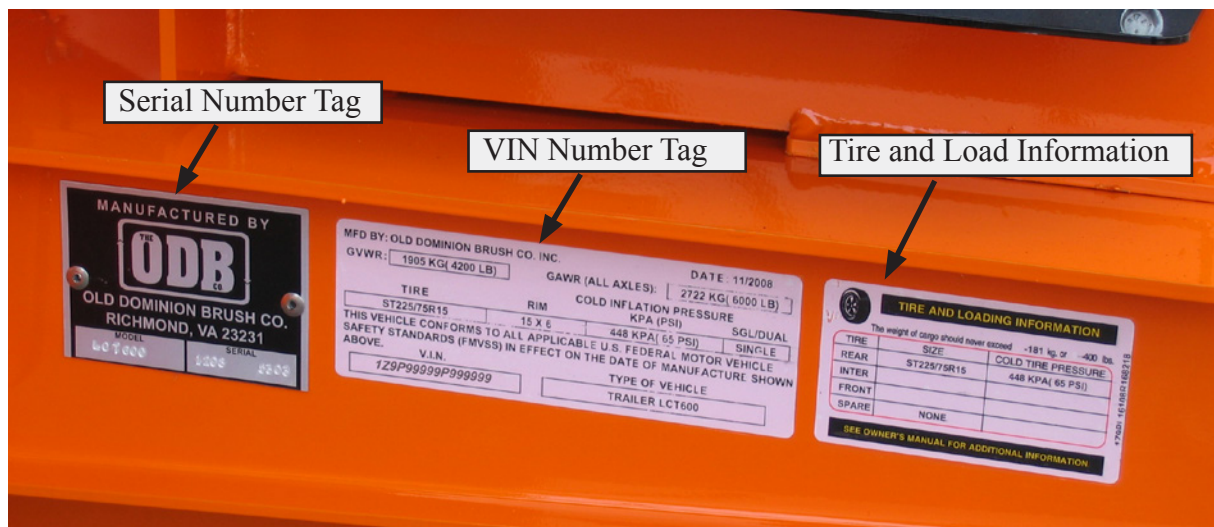

2.0 PRE-OPERATING SECTION

WARNING

Read and understand this entire manual before operating, maintaining or repairing the leaf vacuum.

2.0 Pre-Operating Section

2.0 PRE-OPERATING SECTION

2.0 PRE-OPERATING SECTION

2.1 Instrument and Controls:	18
2.2 Safe Operations:.....	20
2.3 Preparation For Operation.....	22
2.4 Pre-Transport Checks.....	23
2.5 Personal Protective Equipment and Clothing	25
2.6 Work Site Preparation	26

Pre-Operating Section

2.1 Instrument and Controls:

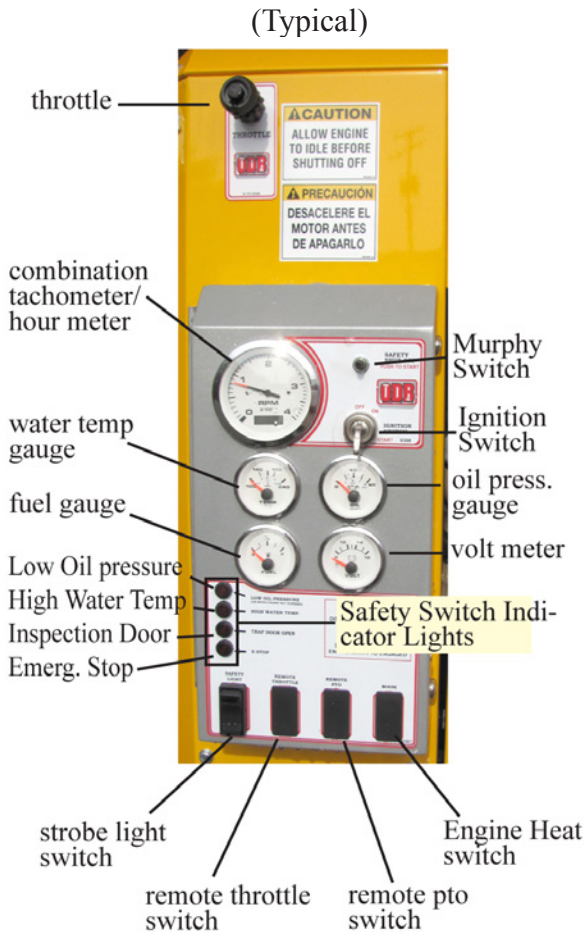

CAUTION

Always make sure the PTO is disengaged before starting unit.

Ignition Switch:

Used to power the accessories and start the unit. Unit will not start without Murphy switch depressed.

ACCESSORIES - first position

STARTER ENGAGE - second position (springs return to first position)

Murphy Switch:

This switch overrides the low oil pressure and high temperature cutoff control. This switch must be depressed before the starter engages. After the engine starts, wait for oil pressure to rise before releasing the button.

Throttle:

This control provides positive locking and vernier adjustment of engine.

Combination Tachometer / Hour Meter:

This gauge indicates the engine r.p.m.'s. The sender is located on the tachometer. The hour meter is digital and indicates the accumulated hours of the engine. This should be used to schedule maintenance.

Volt Meter:

The gauge shows the status of the engine charging system. When the charging system is operating properly it should read approximately 14 volts. If the gauge reads below 13 volts, the alternator is not charging the battery and the system should be checked by a qualified technician.

Oil Pressure Gauge:

Confirms and indicates the presense and pressure of engine oil. If the gauge reads low, it should be checked by a qualified technician.

Engine Temperature:

Indicates the engine coolant temperature. If the gauge reads over 240 degrees the unit should be checked by a qualified technician.

Hour Meter:

Indicates the accumulated hours of the the engine. This should be used to schedule maintenance.

Pre-Operating Section

2.1 Instrument and Controls, cont.:

SAFETY SWITCH INDICATOR LIGHTS

These lights work with the Murphy (safety) shut off switch. When the light is on it indicates that the shut off switch has been tripped and the light indicates which device caused the trip.

Low Oil Pressure Indicator Light:

When lit the engine has reached a low oil pressure reading and has tripped (thus shut off the engine) the safety shut off (Murphy) switch. This light will illuminate when the engine is first started until engine oil pressure has been established.

High Water Temperature Indicator Light:

Indicates the engine coolant temperature has reached 225 degrees and has tripped (thus shut off the engine) the safety shut off (Murphy) switch.

Inspection Door Indicator Light:

Indicates that the limit switch located on the blower housing inspection door has been tripped (thus shut off the engine).

Emergency Stop Switch Indicator Light:

Indicates that the emergency stop switch (on the LCT650 only) has been depressed, tripping the safety switch and shutting off the engine.

ROCKER SWITCHES

Strobe Light Switch:

Turns the strobe light on or off

Remote Throttle Switch (optional):

Increases or decreases the engine throttle. Pressing and holding the top of the switch increases the throttle. The longer the button is pressed the higher the throttle is advanced. Pressing the bottom of the switch decreases the throttle in the same manner as increasing the throttle.

Remote PTO Switch (optional):

Engages or disengages the PTO. Pressing the top of the switch engages the PTO while pressing the bottom of the switch disengages the PTO.

Engine Heat Switch (Cummins engines only):

Press the top of the switch for 20 – 30 seconds initiates the glow plug to aid in starting a cold engine.

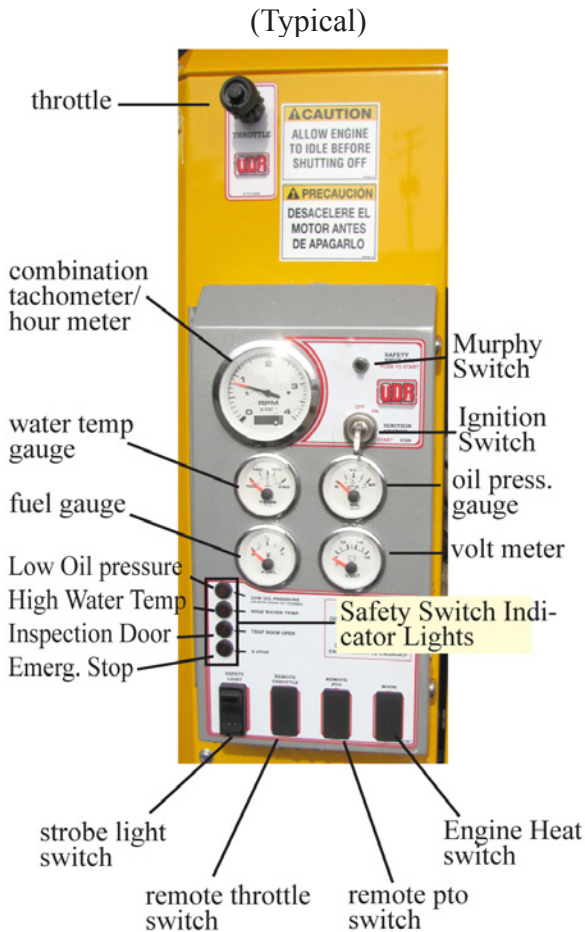

Pre-Operating Section

2.2 Safe Operations:

WARNING

ALL personnel using, maintaining or servicing this unit must be trained in all safety procedures outlined in this manual. Improper or careless use of this equipment CAN result in personal injury or death.

Operations shall be restricted to:

1. Properly trained, qualified and experienced operators and/or qualified and experienced maintenance and test personnel.
2. Trainees under the direct supervision of qualified and experience personnel.
3. Qualified and experienced maintenance and service personnel.

Operators who qualify to operate this equipment under the above restrictions shall also comply with the following physical requirements:

1. Have good vision and the ability to read and understand this manual as well as all safety and operational decals on the equipment.
2. Be capable of hearing, with or without a hearing aid, at a level needed to safely operate this equipment.
3. A record of mental stability with no history of epileptic seizures, dizziness, or any other disability that may result in injury to himself or others.

If any of these requirements are not satisfied at any time, the person failing to meet these requirements **MUST NOT OPERATE THIS EQUIPMENT.**

Pre-Operating Section

2.2 Safe Operations (continued):

Additional Requirements:

1. Each operator must demonstrate competence to understand all safety decals, operator's manuals, safety codes, applicable government regulations, and all other information applicable to the safe and proper operation of the leaf vacuum.
2. Each operator must demonstrate the ability to recognize an emergency situation that may arise during vacuuming operations and the knowledge and procedures to implement corrective action.
3. Each operator must demonstrate or provide evidence of qualification and experience prior to operating the leaf vacuum.
4. Each operator must be able to recognize existing or potential problems regarding the mechanical integrity of the leaf vacuum and report any maintenance requirements to the supervisor in charge.
5. Each operator must wear the proper personal clothing and safety gear. (Refer to SAFETY PRECAUTIONS Section 5.4)
6. Operators must not be physically or mentally fatigued.
7. Operators must not be under the direct or indirect influence of alcohol and/or drugs. This includes prescription drugs that could cause drowsiness, dizziness, or any other condition that would impair their ability to operate or use this equipment in a safe manner.

Pre-Operating Section

2.3 Preparation For Operation

CAUTION

Before your leaf vacuum is put into operation it is very important to read and follow the procedures outlined in the engine owner's manual. (EOM).

For specific information regarding the following checks please refer to the "Maintenance" section of this manual and the engine owner's manual.

WARNING

DISENGAGE the clutch and remove the negative battery cable before performing the following checks.

WARNING

NEVER place any part of the body under or behind guards or any other area in which you cannot see.

IMPORTANT CHECKS:

NOTE: The following checks contained in the next three sections should be performed prior to leaving the storage area.

1. Check engine fuel, coolant and oil levels. (see EOM)
2. Check engine air filter
3. Check all bolts and nuts to ensure they are tight.
4. Check all controls for free and proper operation.
5. Check main drive belt (if equipped) for proper adjustment.
6. Inspect the fan blades to ensure that they are not bent , deformed, fatigued or cracked. Replace fan if any damage is present.
7. Inspect the intake hose flange to make sure it is connected correctly to the blower housing.
8. Inspect the leaf vacuum frame and structure for any bent, broken, cracked, missing or loose parts.
9. Check all guards to ensure they are undamaged, in place and properly secured.
10. All decals must be in place and legible prior to operating the leaf vacuum. See the decal section for decal replacement.

Pre-Operating Section

2.4 Pre-Transport Checks

WARNING

Failure to properly hitch the leaf vacuum to the tow vehicle, verify the road worthiness of the leaf vacuum and the tow vehicle and verify all equipment is properly stowed, may cause serious injury or death to yourself or others.

TOW VEHICLE MUST have proper towing capacity for the leaf vacuum being towed. Check the tow vehicles operating manual for rated capacity.

Do not tow the leaf vacuum unless all important checks listed below are completed.

IMPORTANT CHECKS

1. Hitch is properly secured to tow vehicle and hose boom secured. Frame must be level or the tongue slightly lower than the rear of the leaf vacuum while towing to ensure proper weight distribution. The hitch may have to be adjusted when towing with vehicles of varying tow hitch height.
2. Safety chains installed correctly.
3. Chains routed under trailer tongue in an “X” pattern between tow vehicle and trailer.
4. Slack in chain should be adjusted to permit turning but should not be dragging on the ground.
5. Connect trailer wiring to the tow vehicle and ensure that all trailer lighting is operating properly.
6. Ensure that the safety breakaway switch is functioning properly and attached securely to the tow vehicle. Allow enough slack to ensure that vehicle turns will not activate the safety breakaway switch. **NOTE:** Follow manufacturers procedure to ensure tow vehicles brake control box is properly adjusted.
7. Check the general condition of the tires, tire pressure and ensure that all lug-nuts are securely fastened.

Pre-Operating Section

2.4 Pre-Transport Checks (continued):

8. Visual examination of the leaf vacuum frame, suspension and structure to determine if all components are correctly positioned and secured for travel.
9. Check the intake hose boom to verify that it is securely fastened to the leaf vacuum and can not swing free. (if equipped).
10. Verify there are no loose tools or materials on the trailer, inside the intake and exhaust hoses, or inside the engine sheet metal.
11. Check all cones, wheel-chocks, signs or other support tools and materials to ensure proper stowage.

Pre-Operating Section

2.5 Personal Protective Equipment and Clothing

WARNING

Always wear proper safety equipment as outlined below, not wearing such equipment **CAN** result in serious personal injury or possible death.

IMPORTANT CHECKS:

Anyone operating the leaf vacuum equipment **MUST** wear appropriate protective equipment and clothing to protect them from injury during operations.

PROTECTIVE EQUIPMENT:

1. **Head Protection:** Hard hats without under-chin strapping.
2. **Eye Protection:** Wraparound goggle type eye protection held in place with an elastic band around the head or a hard hat mounted face shield, which provides full protection of the face.
3. Eye protection must meet ANSI Z87.1 standards.
4. **Hearing Protection:** plug type or “muff type” ear protection should be worn at all times while operating the unit.
5. **Breathing Protection:** Paper filter type dust masks should be worn to protect from dirt and dust particles during the vacuuming process.
6. **Reflective Vests:** Highly visible vests should be worn so motorists can see the operator in all weather and lighting conditions.
7. **Work Gloves:** Gloves should be worn to protect the hands and wrists from debris.
8. **Steel Toed Boots:** should be worn to protect the feet.

DANGER

Work clothes **MUST** be close fitting, but not restrictive of movement, without any loose parts that could be entangled in any parts of the leaf vacuum. This includes items such as jewelry, chains and backpacks.

Pre-Operating Section

2.6 Work Site Preparation

WARNING

Never place any part of the body under or behind guards or any other visually obscured area.

Making sure the leaves are clear of possible dangerous material is critical to safe vacuuming. Vacuuming up metal, glass, rocks or other dangerous material CAN cause serious damage to the equipment or personal injury.

The following guidelines must be followed to insure safety.

1. An inspection of the leaves to be vacuumed must be done prior to the vacuuming process. We realize that it is impossible to completely inspect every inch of leaves being vacuumed, but it is imperative that all leaves be inspected for obvious dangerous material before vacuuming.
2. The operator should never be in the line of traffic, the operator should work on the shoulder whenever possible.
3. The operators should place cones or other barriers to provide adequate warnings to vehicles and pedestrians that vacuuming is in progress.
4. Strobe lights on the leaf vacuum and on the tow vehicle should be on at all times for high visibility.
5. Confirm that all operators are wearing proper clothes and personal protective equipment.
6. Restrict all personnel, except the operator from the area near the leaf vacuum. **DO NOT** allow pedestrians, children or animals near the work area.
7. Make sure that the exhaust hose (if equipped) fits properly into the box container so that all debris is blown into the box container.

3.0 OPERATING SECTION

⚠ WARNING

Read and understand this entire manual before operating, maintaining or repairing the leaf vacuum.

3.0 OPERATING SECTION

3.0 OPERATING SECTION

3.1 Starting Engine.....	28
3.2 Engaging the PTO.....	30
3.3 Fluid Drive Coupler (if equipped)	32
3.4 Vacuuming Leaves	33

Operating Section

3.1 Starting Engine

CAUTION

Always make sure the PTO is disengaged before starting unit. (See figure 3b)

WARNING

Thoroughly read and understand the safety and pre-operating sections of this manual before starting the engine.

CAUTION

DO NOT start the engine in an enclosed building. Proper ventilation is required before starting the engine.

Review the Engine Operating Manual supplied with your leaf vacuum for specific start-up, maintenance and operating instructions. It is especially important to review break-in service procedures for brand new units.

Starting Procedure (refer to figures 3a and 3b):

1. Perform all the pre-starting, pre-operating checks outlined in the EOM and in this manual.
2. Make sure the PTO is disengaged as shown in figure 3b.
3. Turn the throttle control (fig. 3a) counter-clockwise 2 revolutions.
4. Depress and hold the Murphy switch while starting.

figure 3a

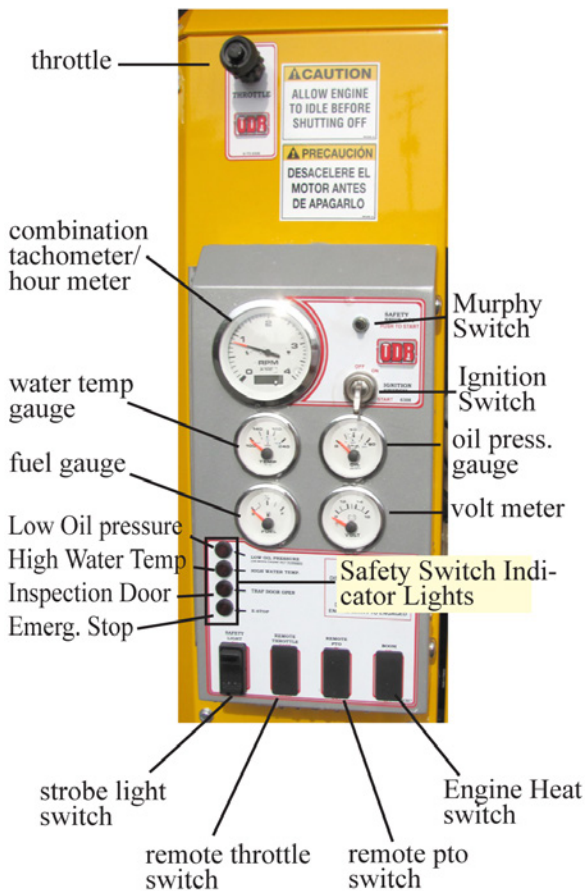

figure 3b



PTO shown engaged

Operating Section

3.1 Starting Engine, continued;

figure 3a

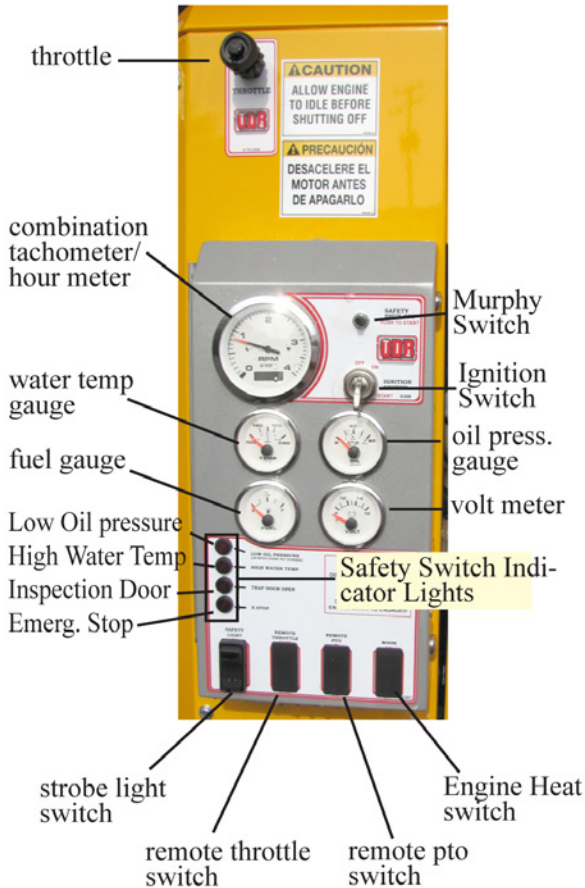

figure 3b



PTO shown disengaged

5. **IMPORTANT:** Do not operate the starter for more than 30 seconds at a time. To do so may overheat the starter. If the engine does not start the first time, wait at least 2 minutes before trying again. If the engine fails to start after 4 attempts, see the trouble shooting section of the EOM and this manual.
6. Turn the ignition switch all the way to the right, when the engine starts release the ignition switch. It should spring back to the first position.
7. **IMPORTANT:** If the ignition switch is released before the engine starts, wait until the starter and the engine stop turning before trying again. This will prevent possible damage to the starter and/or fly-wheel.
8. After the engine starts, continue to hold the Murphy Switch in until the oil pressure gauge reads at least 15 psi. The Murphy shut off switch will not allow the engine to operate below this level. If the gauge does not rise above 15 psi within 5 seconds, stop the engine and determine the cause. Normal operating oil pressure is 50 psi with oil at normal operating temperature.
9. Check all gauges for normal engine operation. If operation is not normal, stop the engine and determine the cause.
10. **IMPORTANT:** To assure proper lubrication, operate the engine at or below 1200 rpm with no load for 1 -2 minutes. Extend this period 2 - 4 minutes when operating at temperatures below freezing.
11. Watch the coolant temperature gauge. Do not place engine under load until it is properly warmed up. The normal engine coolant temperature range is 180 - 202 degrees F.

Operating Section

figure 3b

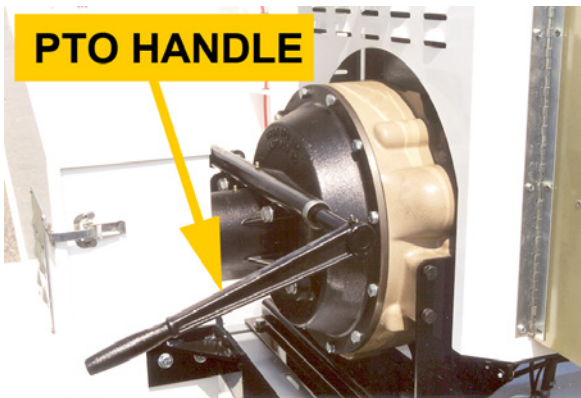

PTO shown disengaged

figure 3c

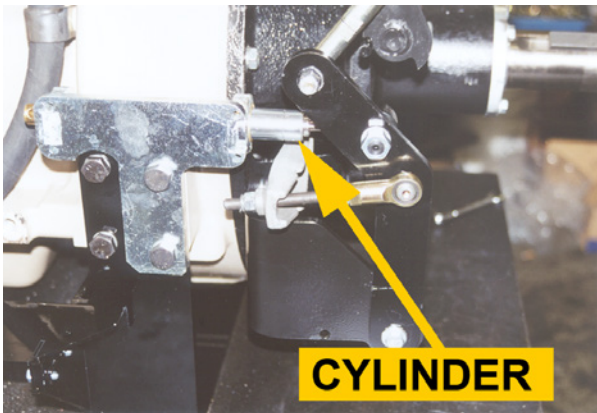

safety assist cylinder

figure 3d

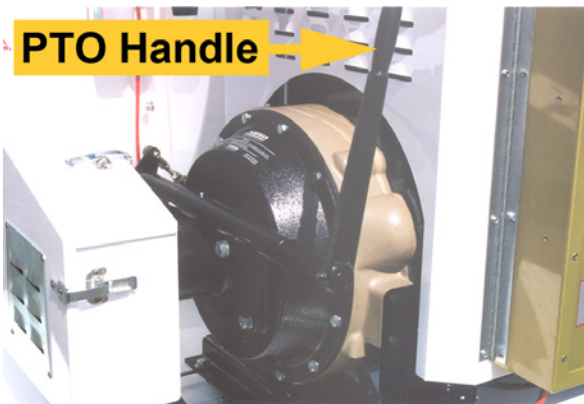

PTO shown fully engaged

3.2 Engaging the PTO

⚠ WARNING

Thoroughly read and understand the safety and pre-operating sections of this manual before starting the engine.

⚠ WARNING

Make sure the intake hose is properly attached and make sure the front of the hose is clear of any objects which could be inadvertently vacuumed during the PTO engagement process.

Review the Engine Operating Manual supplied with your leaf vacuum for specific start-up, maintenance and operating instructions. It is especially important to review break-in service procedures for brand new units.

Engaging the PTO (refer to figures 3b, 3c and 3d):

1. Perform all the pre-starting, pre-operating checks outlined in the EOM and in this manual.
2. Start the engine as previously discussed in this manual and in the EOM.
3. Once the engine has been allowed to thoroughly warm up (engine temperature gauge should read at least 180 degrees) pull the throttle control until the engine reaches 1000 rpm.
4. Grasp the PTO handle (fig. 3b) and slowly raise the handle. **NOTE:** Some units have a PTO assist cylinder which engages the PTO at a specific speed in order to properly engage the PTO. Because of this the PTO handle only needs to be raised slightly, then the assist cylinder will take over and engage the PTO automatically. (fig. 3c)

Operating Section

figure 3d



PTO shown fully engaged

figure 3b

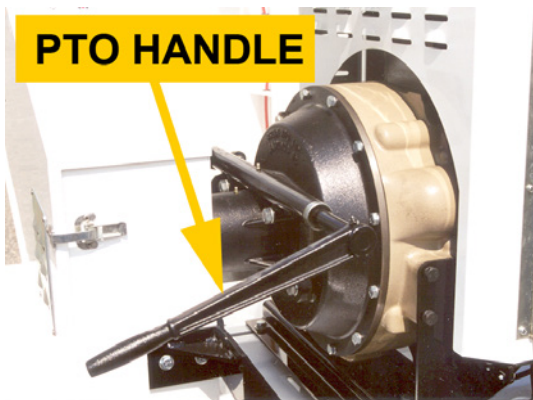

PTO shown disengaged

3.2 Engaging the PTO, continued;

5. **IMPORTANT:** If the unit experiences any heavy vibrations or makes any unusual noises, shut the engine down and after following the necessary safety guidelines, have a qualified technician investigate the cause. **DO NOT** operate a unit that is in a state of disrepair.
6. If the unit is running smoothly and does not display any excessive vibration, the unit is ready to vacuum leaves. **NOTE:** Please see the next section before vacuuming leaves.

Disengaging the PTO (refer to figures 3b and 3d):

1. Decrease the rpm to 1000 rpm.
2. Grasp the PTO handle and slowly disengage the PTO.
3. When the PTO is fully disengaged, the engine can be shut down.

Operating Section

Figure 3.3A

3.3 Fluid Drive Coupler (if equipped)

⚠ WARNING

Thoroughly read and understand the safety and pre-operating sections of this manual before starting the engine.

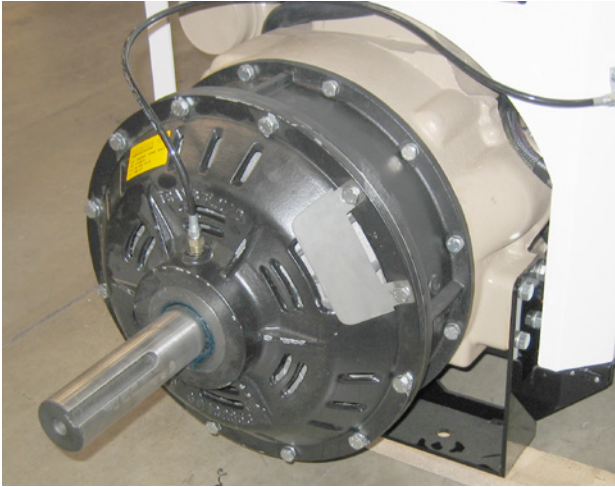

⚠ WARNING

Make sure the intake hose is properly attached and make sure the front of the hose is clear of any objects which could be inadvertently vacuumed at any time.

There is no PTO engagement when the unit is equipped with a Fluid Drive Coupler. The impeller is ALWAYS engaged and rotating.

⚠ WARNING

The suction impeller is ALWAYS rotating when the engine is running and for a few minutes after the engine is shut off. Exercise caution whenever the unit is running.

⚠ CAUTION

IMPORTANT: If the unit experiences any heavy vibrations or makes any unusual noises, shut the engine down and after following the necessary safety guidelines, have a qualified technician investigate the cause. DO NOT operate a unit that is in a state of disrepair.

Operating Section

3.4 Vacuuming Leaves

WARNING

Thoroughly read and understand the safety, pre-operating and operating sections of this manual before vacuuming. Wear the proper safety equipment as outlined in this manual.

WARNING

Make sure the exhaust hose is connected to the box container properly before vacuuming leaves. Visually inspect the leaves before vacuuming for any material that could be harmful to the leaf vacuum or people. This includes bottles, wood, steel, glass, stone or other hard or breakable objects.

Vacuuming Leaves:

1. Start the engine and engage the PTO using the procedures stated earlier in this manual.
2. Set the engine throttle to around 1400 rpm.
3. NOTE: Always vacuum leaves using the lowest rpm as possible. This saves fuel and decreases the amount of dust escaping the box container.
4. Lower the intake hose to a few inches above the leaf pile. Hold the intake nozzle at a 45 degree angle to allow proper air flow. This should allow the leaves to be vacuumed. DO NOT bury the intake nozzle into the leaf pile, this will cut off the air flow and will make vacuuming much more difficult and increase the chance of clogging.
5. If the leaves are not vacuuming, increase the rpm to 1400 and try vacuuming at this setting.
6. NOTE: Wet leaves will need higher rpm's to vacuum whereas dry leaves will only need minimal rpm's.
7. Continue moving the nozzle in a sweeping motion above the leaves while vacuuming.

4.0 MAINTENANCE SECTION



Read and understand this entire manual before operating, maintaining or repairing the leaf vacuum.

4.0 MAINTENANCE SECTION

4.0 MAINTENANCE SECTION

4.1 Maintenance Overview:.....	35
4.2 Maintenance and Lubrication	36
4.3 Lubrication:.....	37
4.4 Preventative Maintenance.....	40
4.5 Torque Values.....	44

Maintenance Section

4.1 Maintenance Overview:

CAUTION

Only properly trained personnel should perform maintenance or repair on this equipment. Consult ODB before performing any maintenance procedures that is not specifically covered in this manual. Improper maintenance or repair may void any and all warranties on this equipment.

WARNING

Improper maintenance or repair CAN result in equipment damage and/or personal injuries.

DANGER

BEFORE CONTINUING, please read and understand the Safety, Pre-operating and Operating sections of this manual before doing any procedures in this section.

A properly maintained leaf vacuum will dramatically extend the life of the unit and will create a safer work place as well. For the general safety and welfare of all personnel it is important to create a scheduled maintenance program that covers all the elements in this manual as well as the engine, PTO and axle owner's manuals provided with this unit.

Use the chart on the following page as a guide for your scheduled maintenance program. If there are any questions concerning any of these procedures please call the factory or your dealer.

Maintenance Section

4.2 Maintenance and Lubrication

This chart is only a reference, always consult the Owners Manual of the Engine, PTO, axles, hoist, etc. for actual recommendations

(Use Hour Meter as a Guide)

ITEM	DAILY/ 10 HOURS	40 HOURS / WEEKLY	80 HOURS / 2 WEEKS
Check Engine Oil Level	X		
Check coolant level	X		
Check Fuel Filter	X		
Lubricate Main Shaft Bearings	X		
Lubricate PTO Bearings	X		
Check Air Filter	X		
Check / Clean Pre-Filter	X		
Check Lug Nuts and Tire Pressure	X		
Inspect Radiator and Radiator Screen	X		
Check Engine as described in Engine's Owner Manual	X		
Inspect Blower Housing Exterior	X		
Check Trailer Lights and Turn Signals	X		
Check Power Band	X		
Inspect Impeller Thoroughly for Damage	X		
Check All Nuts and Bolts for Tightness	X		
Check Tow Bar for Damage / Wear	X		
Check Bolt Hole where Tongue Connects to Trailer	X		
Clean and Inspect Battery and Connections		X	
Inspect Intake and Exhaust Hoses for Wear		X	
Inspect All Ducts for Damage		X	
Remove Blower Face and Inspect Liners for Wear		X	
Check PTO / Clutch Adjustment		X	
Grease / Inspect Wheel Bearings for Corrosion or Wear			X
Inspect all Hydraulic and Fuel Lines for Leaks or Wear			X

Maintenance Section

4.3 Lubrication:

⚠ CAUTION

Remove the negative battery terminal before attempting any lubrication procedures.

⚠ WARNING

Thoroughly read and understand the safety and pre-operating sections of this manual before performing any lubrication procedures.

Figure 4.3A

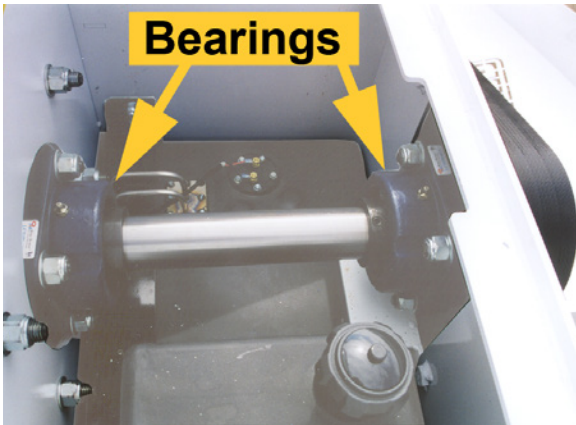

NOTE: DO NOT mix different types of grease. The old grease MUST BE purged before a different type of grease is used. Mixing grease WILL cause premature failure to the bearings.

The following are general lubrication procedures for our standard units. Any special or custom built units may have other lubrication procedures not directly mentioned in this manual. Please consult the factory or your dealer before any lubricating procedures not specifically mentioned in this manual.

Proper lubrication of your unit correlates directly to how long your unit will last. A properly maintained unit will last much longer than a unit that is not maintained properly.

NOTE: Always lubricate bearings at the end of each work day. This will displace any moisture in the bearings. Also lubricate thoroughly before extended shutdown or storage.

Lubrication Points:

1. **Drive Bearings (figure 4.3a):** These bearings are critical components of the belt-driven units. These bearings should be greased every 10 hours with approximately two strokes from the average hand pump grease gun. The type of grease used in these bearings are also critical to the performance of the bearings. A multi-purpose, heavy-load, high-temperature, moisture resistant #2 grease is required for the drive bearings. We recommend Mantek Elite Supreme #1 WG Extreme Duty multi-purpose grease. Other premium quality grease that matches the above requirements may be used but after years of testing we recommends the Mantek grease.



Maintenance Section

4.3 Lubrcation, continued;

Lubrication Points, continued:

- 2. Trailer Wheel Bearings (figure 4.3b):** Most of the units are equipped with "EZ-Lube" grease fittings. This allows the operator to grease the bearings without removing the hubs. The "EZ-Lube" feature consists of axle spindles that have been specially drilled and fitted with a grease zerk in their ends (fig. 4.3c). When grease is pumped into the zerk, it is channelled to the inner bearing and then flows back to the outer bearing and eventually back out the grease cap hole. The trailer wheel bearings should be checked and greased after the first 30 days of service then at the beginning of every season.

Figure 4.3b

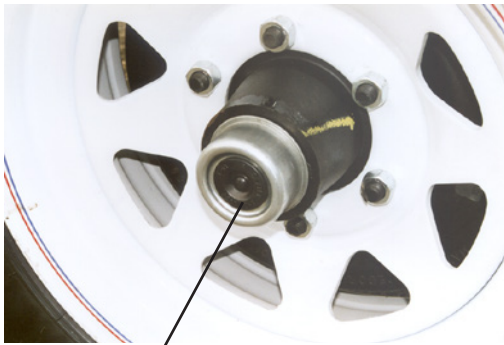

Grease fitting is behind rubber plug

Grease specifications:

Thickener Point.....	Lithium Complex
Dropping Point.....	230 deg. C minimum
Consistency.....	NLGI No.2
Additives.....	EP, Corrosion & Oxidation Inhibitors
Base Oil.....	Solvent refined Petroleum Oil
Base Oil Viscosity.....	@40 deg. C 150cSt Min.
Viscosity Index.....	80 Minimum
Pour Point.....	-10 deg. Minimum

Approved Sources:

Mobil Oil.....	Mobilgrease HP
Exxon/Standard.....	Ronex MP
Kendall Refining.....	Kendall L-427
Ashland Oil Co.....	Valvoline Val-plex EP Grease.
Penzoil.....	Premium Wheel Bearing Grease 707L

For any questions concerning wheel lubrication please consult the axle owner's manual supplied with your leaf collector or contact the manufacturer or dealer.

Figure 4.3c

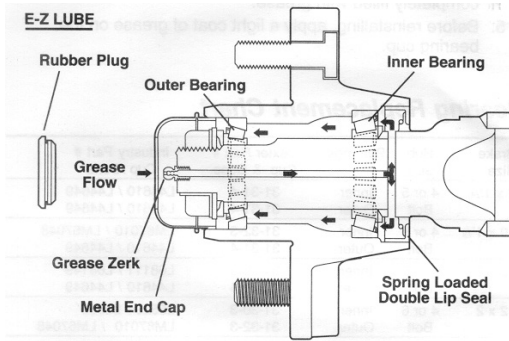

Maintenance Section

Figure 4.3d

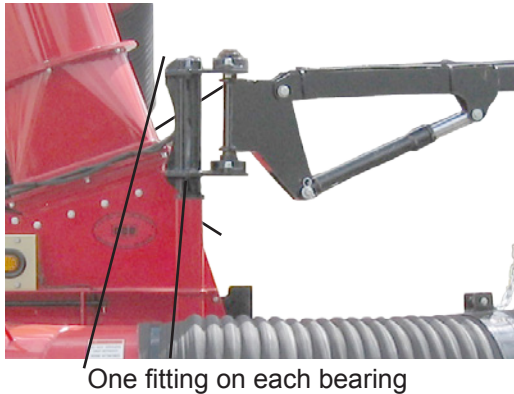

4.3 Lubrication, continued;

Lubrication Points, continued:

- 3. Boom Swivel Bearings (figure 4.3d):** Grease the boom bearings once every week with a multi-purpose moisture resistant #2 grease.
- 4. PTO Bearing & PTO Shaft Fitting (figure 4.3e):** The PTO bearings should be greased after every 50 hours of operation with a high grade, high temperature lithium base #2 lubricant having an operating temperature of 200 degrees F. Three to five pumps with a hand operated grease gun is sufficient. **NOTE:** Units manufactured after 2000 may not have a PTO bearing grease fitting. These bearings are sealed and do not require greasing. The PTO crossover shaft and linkage should be lubricated with high temperature lithium base #2 lubricant after 200 hours of operation.
- 5. Hinge and Friction Points:** Leaf vacuum operation and longevity can be improved by keeping hinges and friction points lubricated. It is recommended that lubrication be performed weekly. Use SAE30 weight oil on hinges and a premium grade, high temperature lithium based EP#2 grease on friction points.
- 6. Hitch and Tongue (figure 4.3f):** The hitch and hitch ring should be checked and lubricated daily to minimize wear. Apply grease and/or SAE30 weight oil wherever applicable.

Figure 4.3e

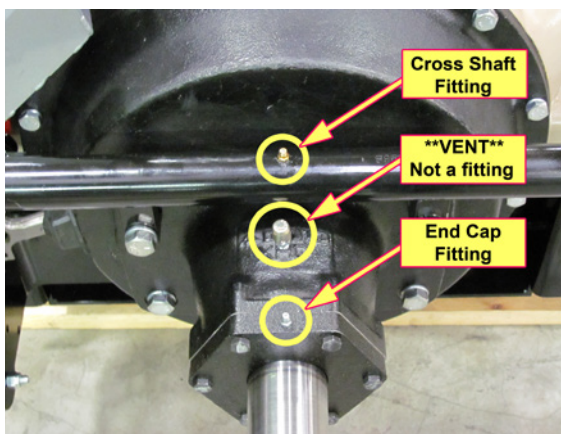
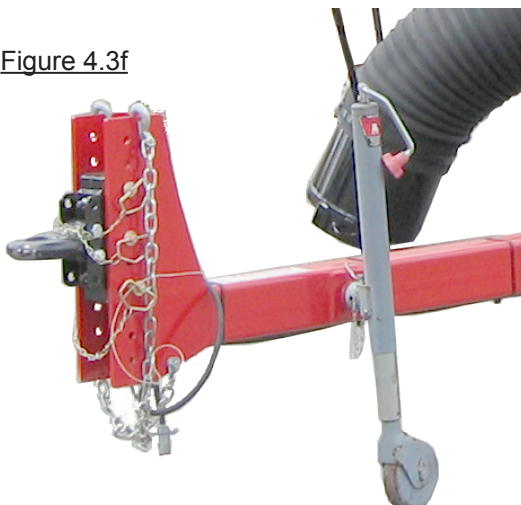

Figure 4.3f



Maintenance Section

4.4 Preventative Maintenance

CAUTION

Remove the negative battery terminal before attempting any maintenance procedures.

WARNING

Thoroughly read and understand the safety and pre-operating sections of this manual before performing any maintenance procedures.

The following are general preventative maintenance procedures for our standard units. Any special or custom built units may have other preventative maintenance procedures not directly mentioned in this manual. Please consult the manufacturer before doing any preventative maintenance procedures not specifically mentioned in this manual.

Proper preventative maintenance of your unit, just like lubrication, correlates directly to how long your unit will last. A properly maintained unit will last much longer than a unit that is not maintained properly.

Preventative Maintenance:

1. **Engine Oil:** Change the oil and oil filter according to schedules provided in your engine's owner's manual (EOM). The engine oil level should be checked every day. The level should be checked after the engine has been stopped for a period of time. This will allow the oil to drain back into the oil pan, allowing a better indication of the true oil level. If the level is low, see the engine's owner's manual for the correct type of oil.
2. **Engine Coolant:** Check the coolant level before starting the unit each day. The coolant level should not be less than one inch below the top of the radiator.

CAUTION

NEVER check the engine coolant when the engine is hot. Allow the engine to cool at least one hour before checking the coolant. Check the engine owner's manual for instructions. **ALWAYS** wear eye and hand protection when working with the radiator.

Maintenance Section

4.4 Preventative Maintenance, continued;

- 3. Engine Radiator:** The engine radiator on a leaf vacuum becomes clogged with dust and debris frequently because of the nature of the job. If the radiator is not cleaned properly it WILL cause improper cooling and WILL eventually cause serious damage to your engine. The debris accumulating on the radiator can be lessened by lowering the RPM on the engine to a level just enough to vacuum the leaves. The higher the RPM the more dust that is put into the air. Also, it may be necessary to put mesh or tarps on the top of the leaf box container to reduce the debris and dust. If this is done, make sure there is enough air ventilation on the box so the box is not blown apart. Proper belt condition and coolant mix-ratio, as well as coolant conditioners, are all critical to proper engine cooling. See

DANGER

NEVER attempt to clean or inspect the radiator with the engine running or while the engine is HOT. Allow the engine to cool at least one hour before maintaining the radiator. Check the engine owner's manual for instructions. ALWAYS wear eye and hand protection when working with the radiator.

the engine owner's manual for specifics on coolant mixture ratios and conditioners. The radiator should be inspected and cleaned with compressed air everyday at the very least.

- 4. Engine Air Cleaner:** Due to the large amounts of dust generated in collection leaves, it is critical to your engine's life that the pre-cleaner and air filter be maintained properly. The pre-cleaner should be cleaned at least daily of any debris that has accumulated. If conditions warrant it should be cleaned more. The air filter should be checked daily and should be replaced at the first sign of it being dirty. DO NOT attempt to clean the air filter, replace the dirty air filter. It is a good idea to clean out the air filter housing once a week to clean any dust debris that may have accumulated
- 5. Tires and Wheels:** Tires and wheel lug nuts should be checked on a daily basis. Tires should be checked for excessive wear and proper air pressure. Check the side wall of the tire for proper inflation pressure. Torque all 1/2" diameter lug nuts from 90 to 120 foot pounds. Torque all 5/8" diameter lug nuts from 175 to 225 foot pounds. Consult the axle manufacturer's manual for more detailed information.

Maintenance Section

4.4 Preventative Maintenance, continued;

- 6. Trailer Brakes (if equipped):** The trailer's brakes should be checked daily, before leaving the equipment yard, for proper operation. The trailer brakes are designed to work in synchronization with your tow vehicles brakes. Never use your tow vehicle or trailer brakes alone to stop the combined load. The synchronization between the tow vehicle and the leaf vacuum is accomplished through the brake controller and needs to be set correctly. Please read the brake controllers manual and the axle owner's manual for these procedures.

WARNING

DO NOT tow the leaf vacuum with damaged or non-operating brakes. Check the brakes daily for proper operation.

The brakes should be adjusted after the first 200 miles of operation when the brake shoes and drums have "seated" and at 3,000 mile intervals, or as use and performance requires. The adjustment procedures are beyond the scope of this manual, please see the axle owners/service manual for specific instructions.

The trailer brakes should be inspected and serviced at yearly intervals or more often as use and performance requires. Magnets and shoes must be changed when they become worn or scored thereby preventing adequate vehicle braking. Again, see the axle owner's/service manual for specific procedures.

- 7. FUEL TANK:** Fill the fuel tank at the beginning of the work shift leaving a gap of at the top of the tank for expansion of fuel. A full fuel tank will reduce the possibility of condensation forming in the tank and moisture entering the fuel lines. Check the fuel lines daily for cracks, holes or tightness.

Maintenance Section

4.4 Preventative Maintenance, continued;

Preventative Maintenance, continued:

CAUTION

ALWAYS wear eye and hand protection when working with the battery.

8. **BATTERY:** The units are supplied with "maintenance free" batteries so there is no need to check fluid levels but the battery terminals should be checked daily for corrosion. Remove any corrosion with a wire brush and coat the terminals with light grease or petroleum jelly to reduce the possibility of corrosion. Also check the battery cable for wear all cable connections and battery tie downs to be certain that they are not loose.





CAUTION

Remove the negative battery cable before opening the belt guard.

9. **DRIVE BELT (if equipped):** The main drive belt should be checked daily for cracks and for proper tension. If the belt shows any sign of cracking it should be replaced immediately. The proper tension of the belt should be approximately 1/2" deflection when applying a 8 pound pull.
10. **FASTENERS:** Fasteners should be checked weekly for the first 30 days and monthly thereafter. They must be in place at all times and properly torqued. For general torque values see the torque chart at the end of this section.
11. **INSTRUMENT PANEL AND CIRCUIT BOARD:** The instrument panel and circuit board should be cleaned with compressed air daily. Also the circuit board connectors should be wiped clean and have nonconductive grease applied weekly to help maintain solid connections.
12. **BOOM HYDRAULIC PUMP:** Check the fluid level daily. If fluid needs to be added, automatic transmission fluid (ATF) is recommended. Clean debris and oil off the solenoid and pump daily. A build up of debris can cause premature failure to the pump. Check and tighten all hydraulic fittings making sure there are no leaks.

Maintenance Section

4.5 Torque Values

<u>INCH BOLT AND CAP SCREW TORQUE VALUES</u>					<u>METRIC BOLT AND CAP SCREW TORQUE VALUES</u>						
TYPE	SAE GRADE					CLASS					
	5		8			8.8 or 9.8		10.9		12.9	
HEAD MARK					HEAD MARK						
SIZE(D)	LB-FT		LB-FT		SIZE(D)	LB-FT		LB-FT		LB-FT	
	Lub*	Dry*	Lub*	Dry*		Lub*	Dry*	Lub*	Dry*	Lub*	Dry*
1/4"	7	9	10	12.5	M6	6.5	8.5	9.5	12	11.5	14.5
5/16"	15	18	21	26	M8	16	20	24	30	28	35
3/8"	26	33	36	46	M10	32	40	47	60	55	70
7/16"	41	52	58	75	M12	55	70	80	105	95	120
1/2"	63	80	90	115	M14	88	110	130	165	150	190
9/16"	90	115	130	160	M16	140	175	200	255	240	300
5/8"	125	160	175	225	M18	195	250	275	350	325	410
3/4"	225	280	310	400	M20	275	350	400	500	460	580
7/8"	360	450	500	650	M22	375	475	540	675	625	800
1"	540	675	750	975	M24	475	600	675	850	800	1000
1-1/8"	675	850	1075	1350	M27	700	875	1000	1250	1150	1500
1-1/4"	950	1200	1500	1950	M30	950	1200	1350	1700	1600	2000
1-3/8"	1250	1550	2000	2550	M33	1300	1650	1850	2350	2150	2750
1-1/2"	1650	2100	2650	3350	M36	1650	2100	2350	3000	2750	3500

***Lub** means coated with a lubricant such as engine oil, or fasteners with phosphate or oil coatings. "Dry" means plain or zinc plated without any lubrication.

DO NOT use these values if a different torque value or tightening procedure is given for a specific application. Torque values listed are for general use only. Check tightness of fasteners periodically.

Make sure fastener threads are clean and that you properly start thread engagement. This will prevent them from failing when tightening. Fasteners should be replaced with the same or higher grade. If higher grade fasteners are used, these should only be tightened to the strength of the original.

Tighten plastic insert or crimped steel-type lock nuts to approximately 50 percent of the dry torque shown in the chart, applied to the nut, not the bolt head.



CAUTION

**DO NOT ATTEMPT TO OPERATE
OR REPAIR
THE LEAF COLLECTOR WITHOUT FIRST
READING AND UNDERSTANDING THIS
MANUAL**

IF YOU HAVE ANY QUESTIONS CONCERNING THE
INSTALLATION OR OPERATION OF THIS UNIT, PLEASE CALL
ODB FOR ASSISTANCE BEFORE ATTEMPTING TO REPAIR OR
OPERATE THE UNIT.

**IMPROPER USE OF ANY MACHINE CAN
RESULT IN SERIOUS INJURY!**

**STUDY AND FOLLOW ALL SAFETY
PRECAUTIONS BEFORE OPERATING OR
REPAIRING UNIT**

THIS MANUAL IS AN INTEGRAL PART OF THE LEAF COLLECTOR AND SHOULD
BE KEPT WITH THE UNIT WHEN IT IS SOLD.

ODB COMPANY
5118 Glen Alden Drive
Richmond, VA 23231
800-446-9823





5.0 SERVICE SECTION

**Service and Troubleshooting
Wiring Diagrams**

ODB COMPANY
5118 Glen Alden Drive
Richmond, VA 23231
800-446-9823



SERVICE AND TROUBLESHOOTING

5.0 SERVICE SECTION

5.1 Engine Electrical Troubleshooting Guide.....	48
5.2 Auto Mfg. Clutch Adjustment - 2008 and after	49
5.3 Hydraulic Boom Troubleshooting Guide.....	50
5.4 Impeller Installation and Removal.....	51
5.4 Impeller Installation and Removal, continued.....	52
5.5 Belt Adjustment and Replacement Guide.....	53
5.6 Flange Bearing Installation and Removal.....	54
5.6 Flange Bearing Installation and Removal.....	55
5.7 Replacing the Blower Housing Liners.....	56
5.7 Replacing the Blower Housing Liners; continued,.....	57

ODB COMPANY
5118 Glen Alden Drive
Richmond, VA 23231
800-446-9823

Service Section

5.1 Engine Electrical Troubleshooting Guide

ENGINE RUNS ONLY WHEN OVERRIDE BUTTON IS DEPRESSED

Make sure the PTO is disengaged.

1. Take a look at the limit switch located at the inspection door of the blower housing. Check to be sure that the inspection door closes completely and that the door presses in the limit switch. The limit switch is extremely sensitive and only needs to open 1/64" to shut the engine off.
2. If the inspection door closes properly and presses in the limit switch properly, then disconnect the two wires from the back of the limit switch.
3. Start the engine using the normal procedure then release the shut off button. If the engines continues to run then the problem lies in the limit switch or the limit switch wiring. If the engine still cuts off then the limit switch is not the cause, go to Testing the shut off switch.

TO TEST THE LIMIT SWITCH:

4. With an ohm meter check the resistance of the terminals A & B (Fig. 1) while the button is not depressed. There should be no resistance or continuity. With the button depressed there should be full continuity or infinite resistance, if not the switch is bad and should be replaced.

TESTING THE SHUT OFF (MURPHY) SWITCH:

5. Turn the ignition switch to the first position.
6. Put a test light to terminal B (Fig. 3) to test for current. If there is no current at B, power is not getting to the shut off switch. Then the problem is not the shut off switch.
7. If there is current at terminal B, put a test light on the fuse at location Z (Fig. 3). If there is no current there the fuse is blown. Replace fuse.
8. If there is current at B and Z, push the override button (letter X, Fig. 3) in on the shut off switch. While the button is depressed place the test light on terminal C (Fig. 3). If there is current at terminal C then the shut off switch is functioning properly and the problem lies elsewhere. If there is no current at terminal C then the shut off switch is defective and needs to be replaced.
9. Next locate the fuel solenoid valve located on the fuel injector pump (Letter C, Fig. 2). It has an orange wire running to it. Pull the ignition switch to the first position. Put a test light on the terminal of the fuel solenoid where the wire is attached. Test light should light up showing current, if not shut off switch is bad. Replace.
10. If engine still cuts off after shut off button is released then test the water temperature switch (located on the engine block, Letter D, fig. 2) by removing the brown wire attached to the temperature switch. Start the engine using the normal procedure then release the shut off button. If the engine continues to run then the water temperature switch is defective. Replace the switch. If the engine shuts off, do the same test on the oil pressure switch. If the engine continues to shut off after this test call ODB for additional service procedures.

Limit Switch (Fig. 1)

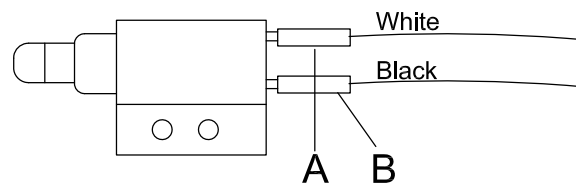

Typical Wiring (Fig. 2)

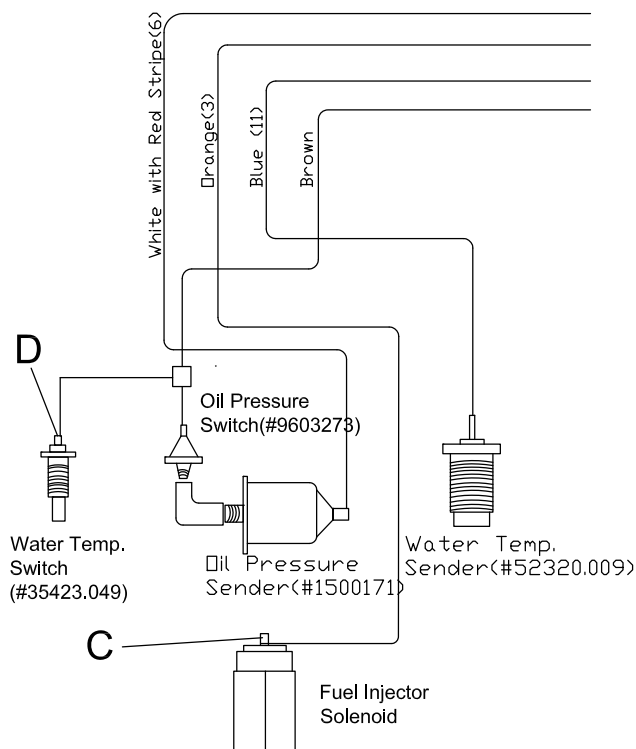

Murphy Switch (Fig. 3)

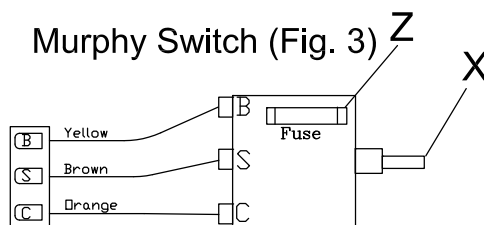

Service Section

5.2 Auto Mfg. Clutch Adjustment - 2008 and after

CAUTION

Rotating Shafts, pulleys, and moving belts can cause severe injury or can be fatal. The engine and driven unit **MUST** be completely stopped before any adjustments or work is attempted to the engine, driven unit, or the PTO clutch itself.

The clutch linkage should be checked after the first 15 hours of operation and every 40 hours there after. An improperly adjusted clutch can result in premature wear to the clutch disc, flywheel and the throwout bearing and will void the warranty on the clutch and PTO.

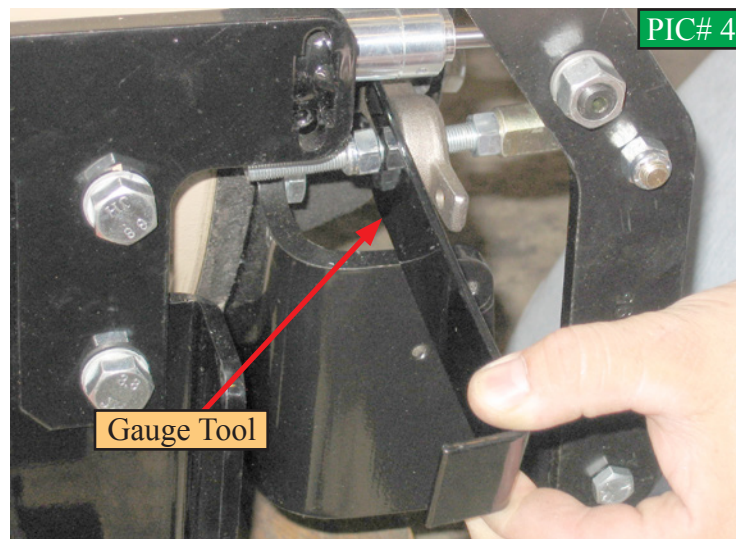
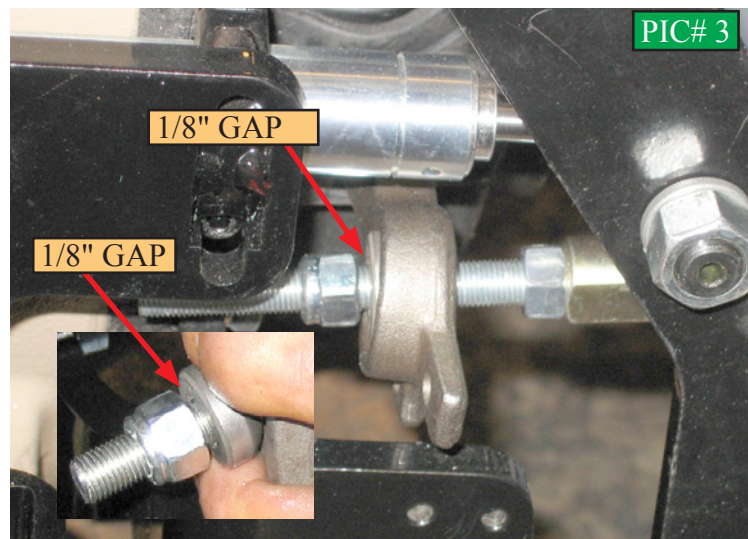
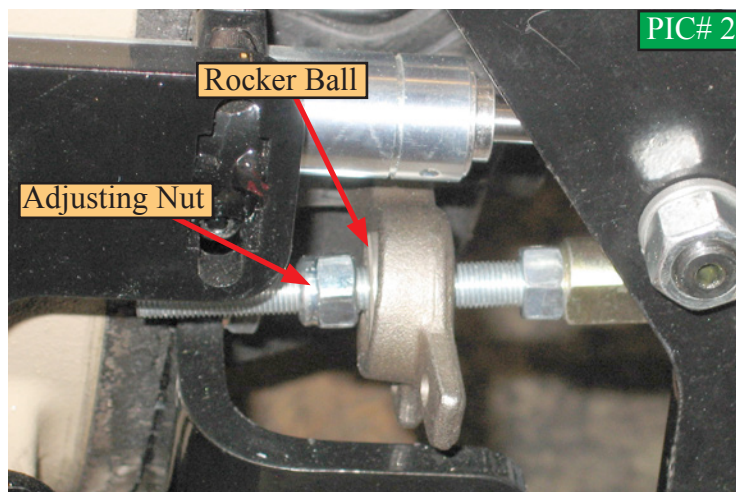
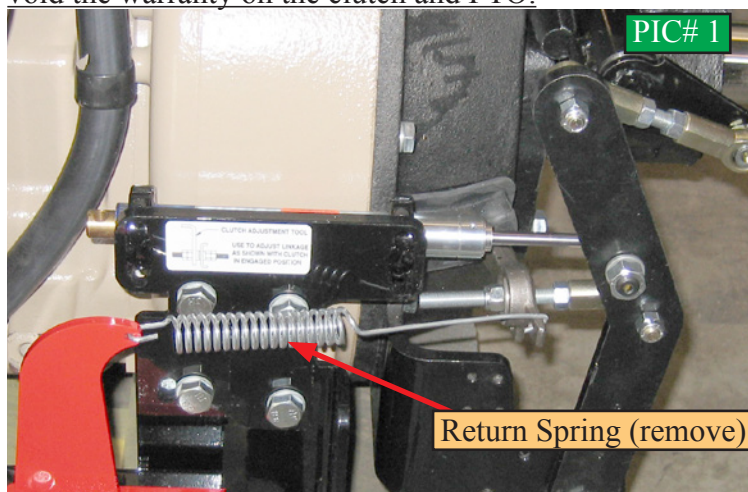

ADJUSTMENT OF THE CLUTCH LINKAGE

1. Make sure the engine is OFF and remove the negative battery cable to ensure the unit can not accidentally be started.
2. Remove the spring from the throwout arm. (See PIC# 1) An accurate measure of the arm tension CAN NOT be made with the spring attached.
3. With the clutch in the engaged position (the PTO is engaged when the PTO handle is pointing straight up on the LCT600 and LCT6000 and pointing out to the side (3 o'clock) on the LCT60C, LCT650 and SCL800TM) adjust the nut (See PIC# 2) against the "rocker ball" until a 1/8" gap between the nut and rocker ball is visible (See PIC# 3).
4. If available, use the special 1/8" gauge tool to slip between the nut and rocker ball. With the proper adjustment the gauge should slide between the nut and rocker ball with a slight amount of pressure. (See PIC# 4)
5. Move the adjustment nut to create the 1/8" gap.
6. Re-install the return spring.
7. Place the handle in the disengaged position. Check to make sure that the PTO output shaft turns freely.

Service Section

5.4 Impeller Installation and Removal

⚠ CAUTION

Before removing the blower housing face remove the negative battery cable to ensure unit can not be started.

REMOVAL

1. The blower housing face must be removed to gain access to the impeller. Use an overhead crane or forklift to support the face while removing.
2. Once the face has been removed, remove the shaft protector (Fig. 1 or 2).
3. Saturate the shaft and bushing using a penetrating lubricant to help loosen the bushing. Clean any grease or debris from the bushing and shaft.
4. Remove the 3 bolts attaching the bushing to the impeller.(Fig. 3) Being careful not to break the bolts. If a set screw is on the lip of the bushing, loosen it using an allen wrench.(Fig. 4)
5. Using two of the bolts that were just removed screw those bolts into the threaded holes on the bushing. Drive the two bolts into the bushing.(Fig. 5) This will separate the bushing from the impeller. Alternate from one bolt to the other driving only about a 1/4" at a time to keep the bushing coming out straight. It is imperative to keep the bushing straight to remove it.

IMPORTANT: Be sure to drive the bushing out evenly or it will get in a bind making removal much harder.

6. If the bushing does not come off using the two bolts, drill and tap several additional 3/8-16 holes around the bushing. Using Grade 8, 3/8-16 - 2 inch bolts, alternately drive the bolts 1/4" at a time to remove the bushing. **KEEP THE BUSHING STRAIGHT** while removing.

IMPORTANT: If additional holes were drilled in the bushing, it can not be reused. It must be replaced.

7. Once the bushing has been removed use an overhead crane or other suitable device to help lift the impeller out of the blower housing.
8. At this point it would be a good idea to inspect the blower housing liners and blower housing for any damage or wear. Any damage or wear to the liners should be fixed by replacing the liners immediately.

Fig. 1

Direct
Drive



Fig. 2

Belt
Drive



Fig. 3

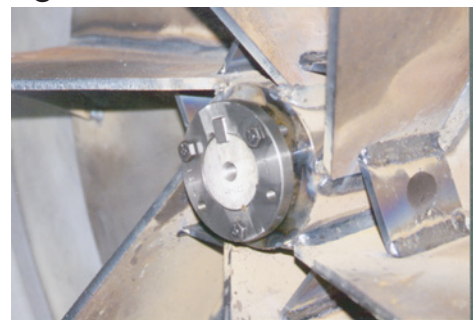

Fig. 4



Fig. 5



Service Section

5.4 Impeller Installation and Removal, continued

CAUTION

Before removing the blower housing face remove the negative battery cable to ensure unit can not be started.

INSTALLATION

1. Clean the shaft of any debris and remove any rust using a 120 grit emory cloth.
2. Using an overhead crane or other suitable lifting device lift the impeller on to the shaft. Turn the impeller to align the keyways of the shaft with the keyway in the impeller.
3. Insert key into the keyway. A light sanding of the keyway may be needed, as well as a few light blows with a rubber mallet.
4. Tap the bushing onto the shaft aligning the keyways.
5. BELT DRIVE UNITS: Align the bushing and key to be flush with the end of the shaft (Fig 1).
6. DIRECT DRIVE UNITS: The bushing and key should protrude from the shaft about 1/2 inch (Fig. 2).
7. Put the 3 bolts into the non-threaded holes and drive them into the impeller holes evenly. Alternate between the three bolts as you drive the bolts in. Torque to 40 to 50 lbs/ft. There should be a gap of 3/8" to 1/2" between the bushing and the impeller.

IMPORTANT: Slowly spin the impeller by hand making sure that the back of the impeller is not hitting any of the bolt heads located at the back of the blower housing.

8. If the bushing has a set screw on it, tighten the screw snug with an allen wrench (Fig. 3). This will help keep the key in place.
9. Install the shaft protector on to the shaft (Fig. 4 or 5).

Fig. 1



Fig. 2



Fig. 3



Fig. 4

Direct
Drive



Fig. 5

Belt
Drive



Service Section

5.5 Belt Adjustment and Replacement Guide

⚠ CAUTION

Before opening the belt cover remove the negative battery cable to ensure unit can not be started.

Belt Removal

1. Make sure the leaf vacuum is not running and remove the battery cable from the negative battery terminal to ensure that the unit cannot be accidentally started.
2. Open the belt guard assembly to gain access to the belt and pulleys.
3. Loosen the four motor mount bolts (Items A and B, figures #1 and #2) located above the motor mount adjustment brackets.
4. To create slack in the belt, the motor assembly needs to be moved toward the blower housing. Locate the adjustable motor mount nuts (C) at the rear of the unit (figure #3). Use a 7/8" socket to turn the nuts counter-clockwise alternating between the left and right mounts. Move one side approximately two inches then move the other side to keep the mounts from binding.
5. Continue moving the motor inward until the belt is loose enough to be removed.

Belt Replacement

1. Place the belt around the two pulleys, aligning the grooves of the belt with the grooves of the pulley.
2. The motor assembly needs to be moved back away from the blower housing to tighten the belt. Using the adjustable motor mount nuts at the rear of the unit (Item C, figure #3) turn one of the nuts clockwise to start moving the motor assembly. Move the motor assembly approximately two inches then do the same to the other side. Continue alternating between the two sides until the belt is tight.
3. **IMPORTANT:** Use a straight edge to make sure the pulleys are aligned (figure #4).
4. If the pulleys are not aligned use either of the adjustable motor mount nuts to compensate for the mis-alignments. Check the tightness at the center of the belt between the two pulleys. The belt should depress approximately 1/2".
5. Tighten down the 2 bolts closest to the blower housing (Item A, figures #1 and #2). Loosen the adjustable motor mount nuts (Item C, figure #3) by turning counter-clockwise a couple of turns until the front 2 motor mount bolts (Item B, figures #1 and #2) are completely straight. The motor assembly should not move, if it does move then the bolts (Item A) were not tight enough and the belt would need to be readjusted using the steps above. Once the bolts (Item B) are straight tighten them down.
6. Close the belt guard assembly and secure it with the latches.
7. Re-attach the battery cable to the negative battery post.
8. Start the engine and increase the throttle to 750 RPM's.
9. Engage the clutch, listening for any squealing from the belt. If the belt squeals use the above directions to tighten the belt a little more.
10. After approximately 8 hours of use the new belt should be checked for proper tightness in case the belt stretched.

Figure #1

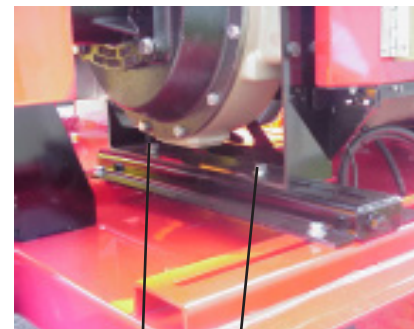

Figure #2



Figure #3



Figure #4



Service Section

5.6 Flange Bearing Installation and Removal

FIGURE #1

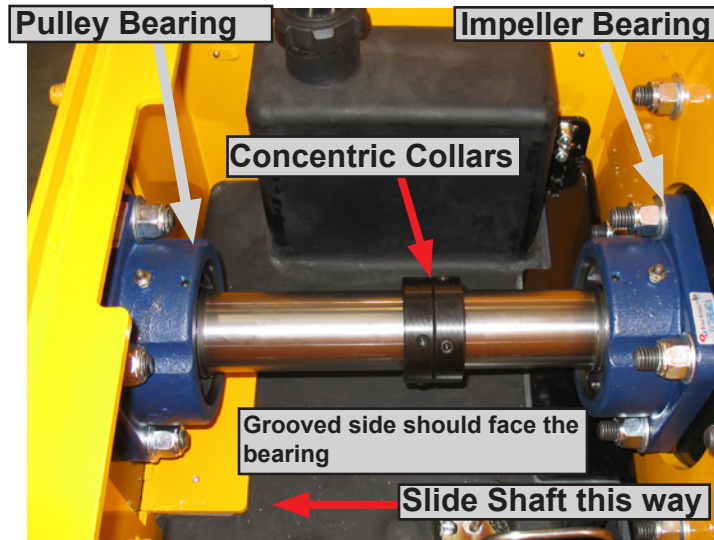

1. Place the bearings on to the black bearing plates inside the pedestal. Hand tighten the bolts onto the nuts at this point.
2. Slide the shaft through the back of the impeller bearing and half way to the pulley bearing. The shaft should fit tight. Clean the shaft and remove any burrs if necessary. Also lightly polishing it with a fine emery may ease installation.
3. Before going through the pulley bearing, place both concentric collars (black collars) onto the shaft (figure #1). Make sure the grooved side is facing the bearing.
4. Continue sliding the shaft through the pulley bearing until the shaft protrudes out from the pulley side 5-5/8". (Figure #2)
5. Now slide the concentric collar toward the respective bearing making sure the grooved side is toward the bearing.
6. Turn the concentric collar clockwise until it slips over the inner ring extension and engages the eccentric. Turn by hand until the parts are locket together.
7. Place a punch or drift in the blind hole in the collar and strike it sharply to lock the collar and ring tightly together (figure #3)
8. Tighten the set screws with an Allen wrench until the set screw stops turning and the Allen wrench starts to spring. (Figure #4)
9. Completely tighten all four of the nuts to secure each bearing.

FIGURE #2

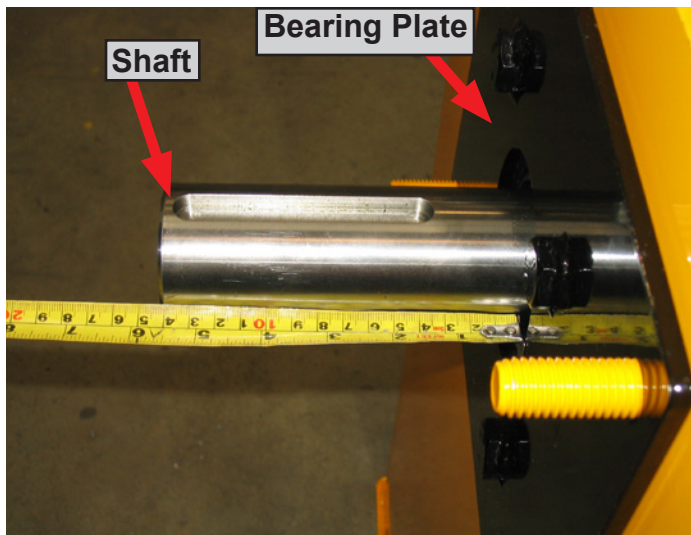

Continued... →

FIGURE #3

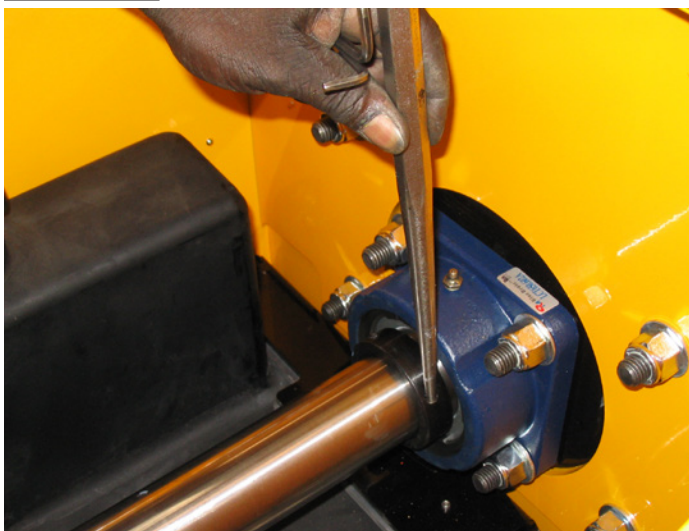

FIGURE #4



Service Section

5.6 Flange Bearing Installation and Removal

FIGURE #5

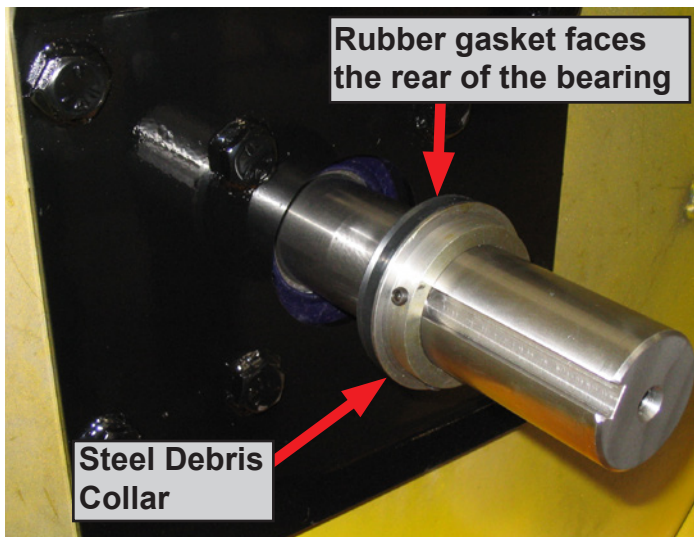

1. Now move to the blower housing where the shaft comes out from the bearing. Put the steel debris collar (chrome color with a rubber seal on one side) onto the shaft with the rubber gasket side facing the rear of the bearing (away from the impeller). See Figure #5.
2. Push the steel collar seal up to the bearing and make sure the groove in the collar goes inside the groove in the bearing. (Figure #6) This creates the sealed fit to keep debris out of the bearing.

NOTE:

3. If the collar is too large for the hole in the bearing plate, a "new style" bearing plate will need to be ordered that has a larger diameter hole. Units manufactured before April 2002 will most likely need to be converted to the new bearing plate (part number LCT600.603 {all but LCT6000} and LCT630.104A for the LCT6000. This plate is for the blower housing or impeller side only. The pulley side bearing does not use the steel debris collar.
4. Completely tighten the two Allen head screws. See figure #6.

NOTE:

Each bearing comes with a steel debris collar but it will be used only on the bearing on the impeller side. You may discard the other collar if you're replacing the pulley bearing.

FIGURE #6



Service Section

5.7 Replacing the Blower Housing Liners

figure 5.5a

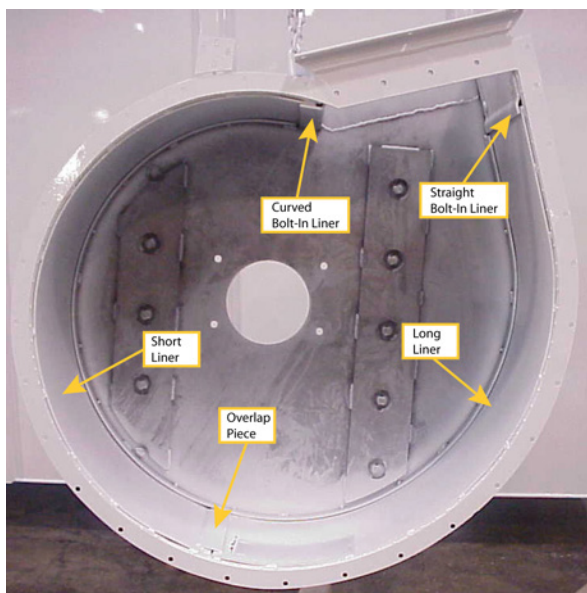

WARNING

Thoroughly read and understand the safety and pre-operating sections of this manual before working on the unit.

WARNING

Make sure the negative battery cable is disconnected before opening the blower housing.

Review the safety section of this manual before attempting these procedures. To gain access to the interior of the blower housing please see the previous sections.

Removing and installing the Liners (refer to 5.5a and 5.5b):

WARNING

Keep all fuel and fuel fumes away from the unit when grinding or welding. Work only in a well ventiated area.

1. Unbolt the the blower housing face as described previously in this manual.
2. Remove the curved and straight bolt-in liners by removing the appropriate bolts.
3. With a grinder cut out the remaining welds to free the liners. DO NOT remove the "stop piece" at the bottom of the housing.

TO INSTALL:

1. Place the short liner into lip at the rear of the housing and line up the bottom of the liner with the "stop" at the bottom of the housing. The short liner has the overlap piece on it and should be installed as shown in the pictures at the left.
2. Tack weld the liner in place every 8 to 10 inches to help keep the liner in place.

figure 5.5b

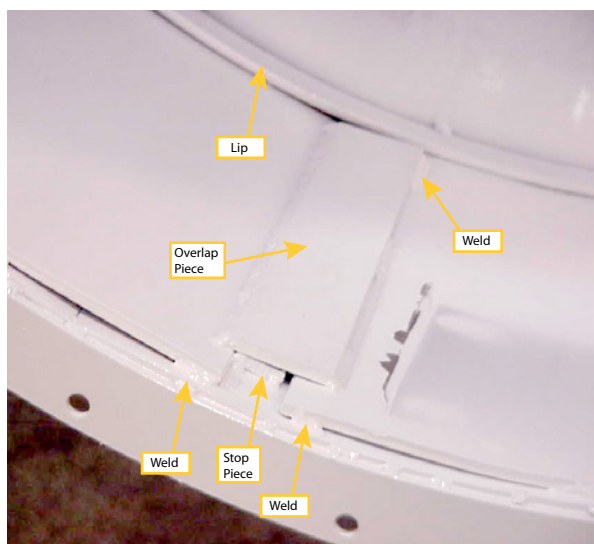

Service Section

5.7 Replacing the Blower Housing Liners; continued,

figure 5.5a

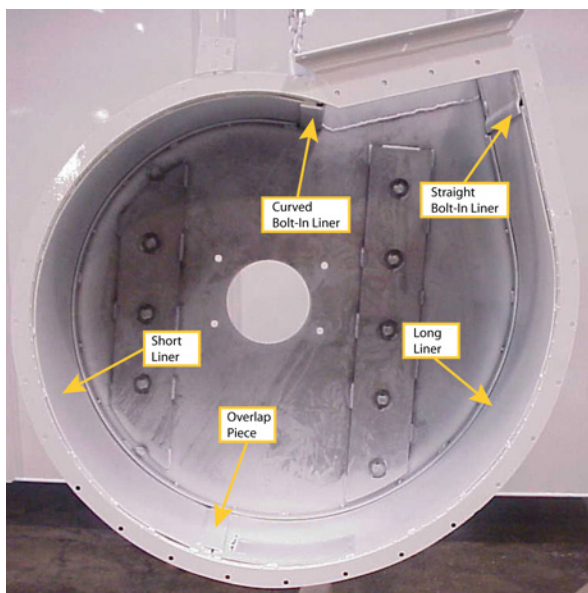

⚠ WARNING

Thoroughly read and understand the safety and pre-operating sections of this manual before working on the unit.

⚠ WARNING

Make sure the negative battery cable is disconnected before opening the blower housing.

Review the safety section of this manual before attempting these procedures. To gain access to the interior of the blower housing please see the previous sections.

Installing the Liners (refer to 5.5a and 5.5b), continued;

⚠ WARNING

Keep all fuel and fuel fumes away from the unit when grinding or welding. Work only in a well ventiated area.

3. Install the long liner the same way as the short liner except the long liner should slip under the overlap piece. Make sure the liner slips under the rear lip and the overlap piece.
4. Tack weld the long liner to the overlap piece and tack weld around the liner as you did on the short liner.
5. Install the two bolt-in liners just as they were removed.

figure 5.5b

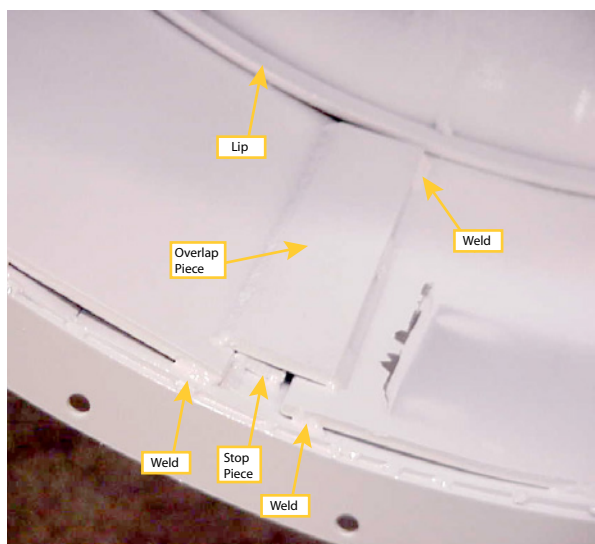



WIRING DIAGRAMS

5.10 WIRING DIAGRAMS

5.10 WIRING DIAGRAMS

5.10.1 Engine Wiring Diagram	59
5.10.2 Engine Main Harness - Enlarged	60
5.10.3 Auxillary Engine Harness - Enlarged.....	61
5.10.4 Engine Wiring Harness Descriptions	62
5.10.4 Engine Wiring Harness Descriptions, continued	63
5.10.5 Engine Rocker Switch Wiring Diagrams	64
5.10.6 Main Circuit Board	65
5.10.7 Main Circuit Board Plug Diagrams	66
5.10.8 Trailer Plug Wiring Diagram	67
5.10.9 Trailer Wiring Harness	68
5.10.10 Brake Wiring Harness	69
5.10.11 Boom Wiring Diagram.....	70
5.10.12 Remote Throttle / Clutch Wiring Harness	71
5.20.1 Wiring Harness Diagram 2 Section Valve Body - 2 Axis	72
5.20.2 Wiring Harness Diagram 4 Section Valve Body - 3 Axis	73

ODB COMPANY
5118 Glen Alden Drive
Richmond, VA 23231
800-446-9823

Service Section

5.10.1 Engine Wiring Diagram

Engine Wiring Harness Diagram

June 2005 and after

Please see enlarged diagrams on the following pages:

1

Engine Main Harness

2

Aux Engine Harness

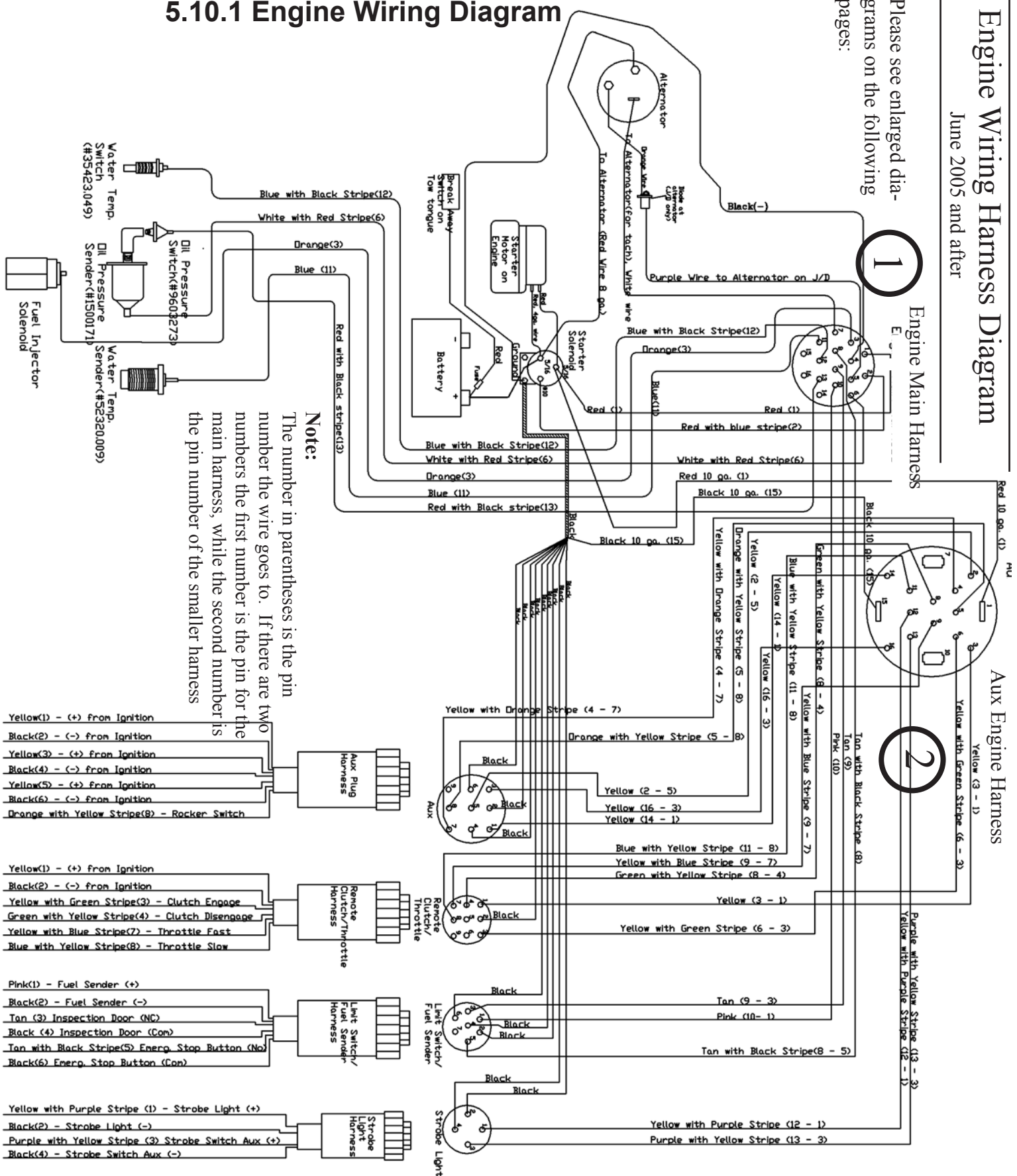

Note:
The number in parentheses is the pin number the wire goes to. If there are two numbers the first number is the pin for the main harness, while the second number is the pin number of the smaller harness

Service Section

5.10.2 Engine Main Harness - Enlarged

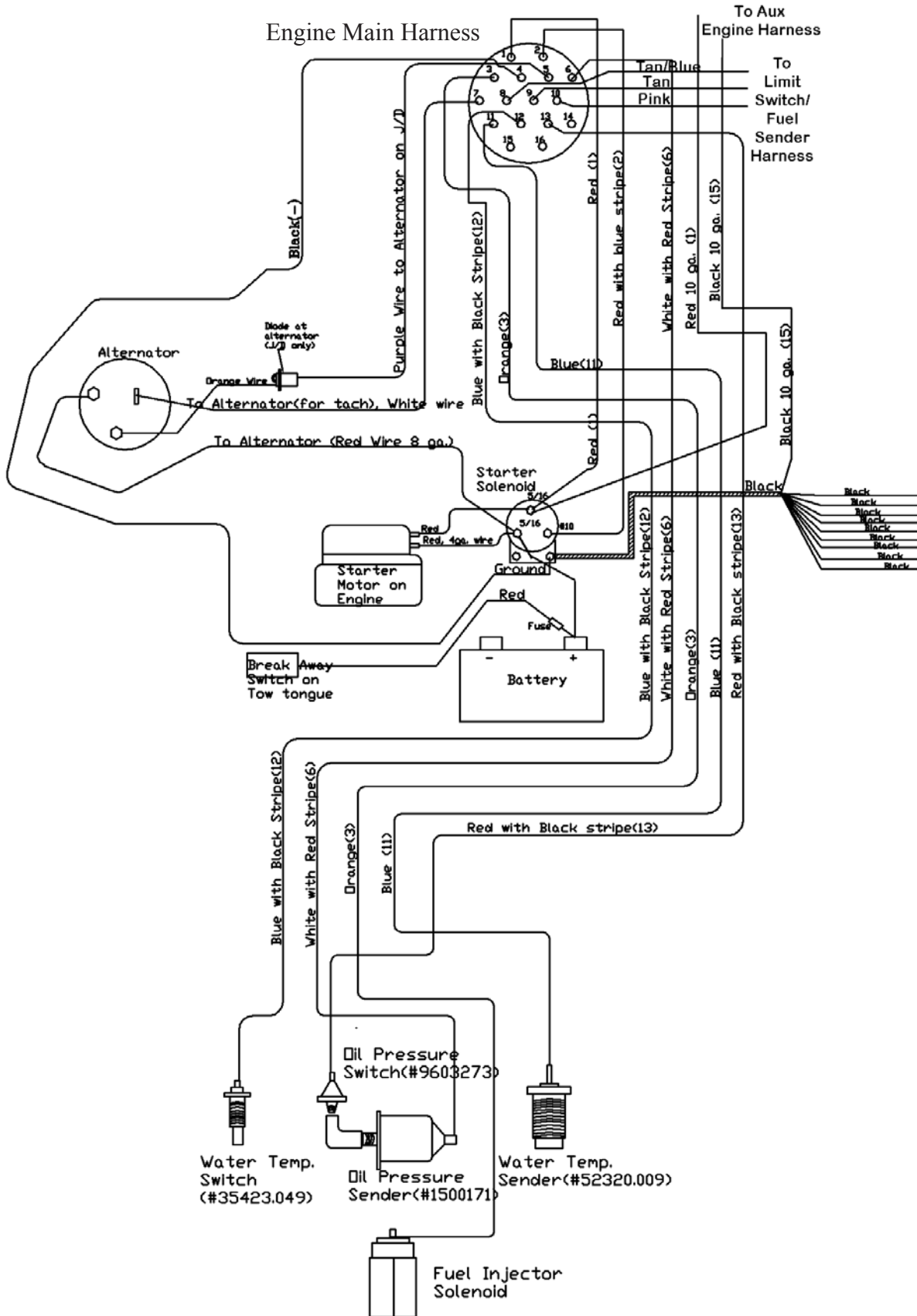

Service Section

5.10.3 Auxillary Engine Harness - Enlarged

Aux Engine Harness

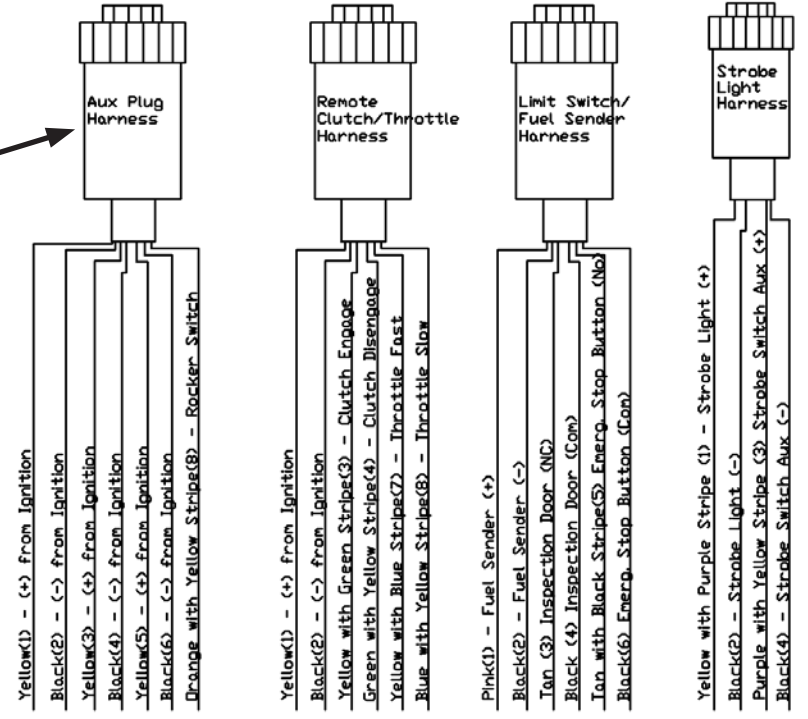
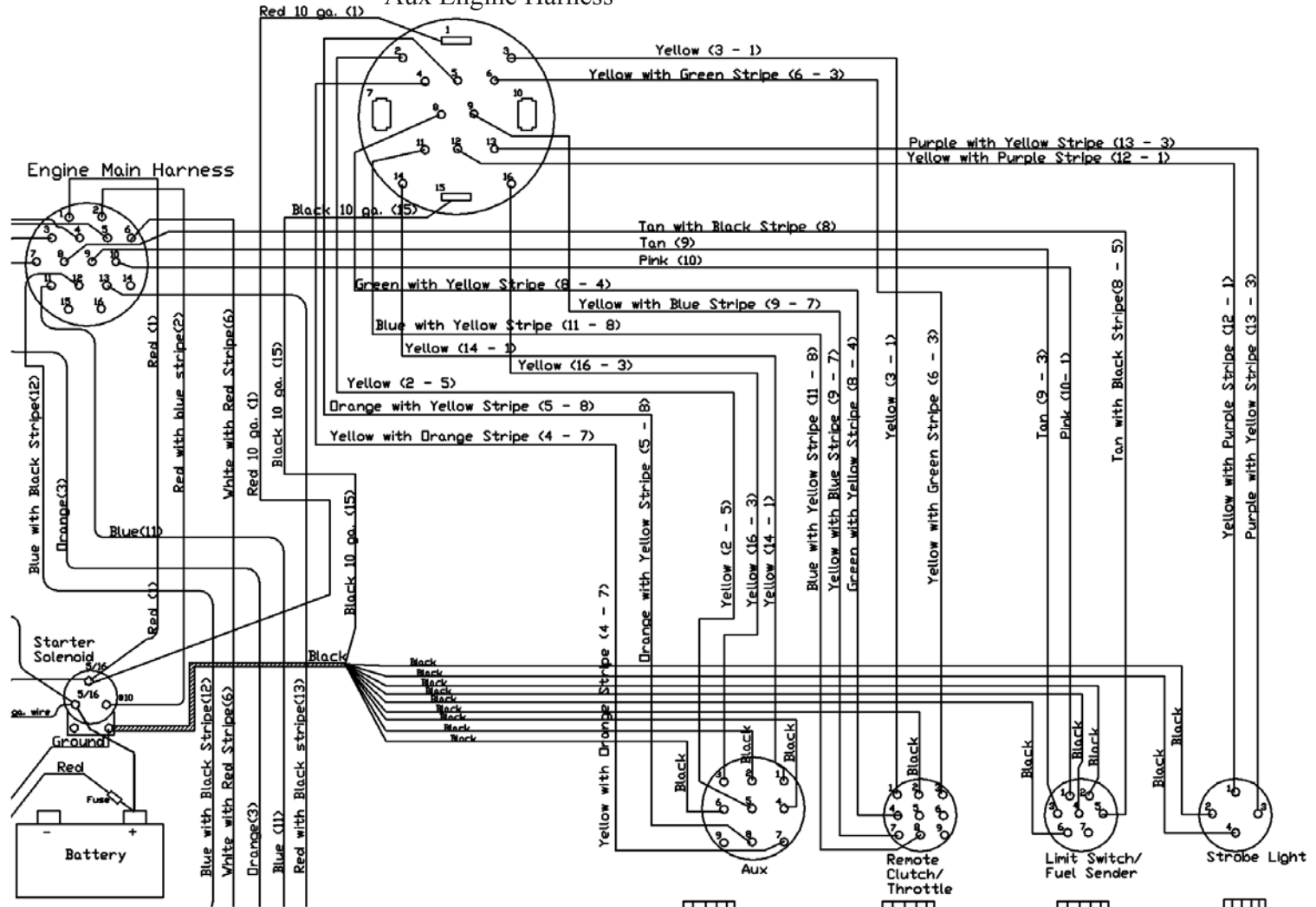

Note:
Not all wires will be installed in the small harnesses. If the unit wasn't ordered with the factory installed option then the wiring to that option may not be included in the harness

Service Section

5.10.4 Engine Wiring Harness Descriptions

ENGINE MAIN HARNESS		
PIN #	COLOR	DESCRIPTION
1	Red	"+" from Solenoid (battery)
2	Red w/ Blue Stripe	Starter Solenoid
3	Orange	Fuel Shutoff Solenoid
4	Black	"-" from Solenoid (battery)
5	Purple	Alternator Energize "+"
6	White w/ Red Stripe	Oil Sender
7	White	Tach Signal from Alternator
8	Tan w/ Black Stripe	Emergency Stop Button (650 only) goes to Limit Switch plug pin #5
9	Tan	Inspection Door on Blower Housing, goes to Limit Switch plug pin #3
10	Pink	Fuel Sender, goes to Limit Switch Plug pin #5
11	Blue	Water Temperature Sender on Engine Block
12	Blue w/ Black Stripe	Water Temperature Switch on Engine Block
13	Red w/ Black Stripe	Oil Pressure Switch on Engine Block
AUXILLARY ENGINE HARNESS		
1	Red 10 Gauge	"+" from Solenoid (Battery)
2	Yellow	Aux "+" from Ignition; goes to Aux Plug Harness pin #5
3	Yellow	Aux "+" from Ignition; goes to Remote Clutch Harness pin #5
4		
5		
6	Yellow w/ Green Stripe	Clutch Engage; goes to Remote Clutch Harness pin #3
7	[empty]	
8	Green w/ Yellow Stripe	Clutch Disengage; goes to Remote Clutch Harness pin #4
9	Yellow w/ Blue Stripe	Throttle Fast; goes to Remote Clutch Harness pin #7
10	[empty]	
11	Blue w/ Yellow Stripe	Throttle Slow; goes to Remote Clutch Harness pin #8
12	Yellow w/ Purple Stripe	Strobe Light "+"; goes to Strobe Light Harness pin #1
13	Purple w/ Yellow Stripe	Strobe Light Aux; goes to Strobe Light Harness pin #3
14	Yellow	Aux "+" from Ignition; goes to Aux Plug Harness pin #1
15	Black 10 gauge	"-" from Solenoid (Battery)
16	Yellow	Aux "+" from Ignition; goes to Aux Plug Harness pin #3
STROBE LIGHT HARNESS		
	Yellow w/ Purple Stripe	Fuel Sender "+"; came from Engine Main Harness pin #10
	Black	Strobe Light "-"; came from ground to solenoid
	Purple w/ Yellow Stripe	Strobe Switch Aux "+"; came from Aux Engine Harness pin #13
	Black	Strobe Switch Aux "-"; came from ground on Solenoid

Continued ... -->

Service Section

5.10.4 Engine Wiring Harness Descriptions, continued

FUEL & LIMIT SWITCH HARNESS		
	Pink	Fuel Sender "+"; came from Engine Main Harness pin #10
	Black	Fuel Sender "-"; came from ground to solenoid
	Tan	Inspection Door "+"; came from Engine Main Harness pin #9
	Black	Inspection Door "-"; came from ground to solenoid
	Tan w/ Black Stripe	Emergency Stop Button "NO"; came from Engine Main Harness #8
	Black	Emergency Stop Button "COM"; came from ground on Solenoid
	[empty]	
REMOTE THROTTLE AND CLUTCH HARNESS		
1	Yellow	"+" from Ignition; came from Aux Engine Harness pin# 3
2	Black	"-" from Ignition; came from ground on Solenoid
3	Yellow w/ Green Stripe	Clutch Engage; came from Aux Engine Harness pin# 6
4	Green w/ Yellow Stripe	Clutch Disengage; came from Aux Engine Harness pin# 4
5	[empty]	
6	[empty]	
7	Yellow w/ Blue Stripe	Throttle Fast; came from Aux Engine Harness pin# 9
8	Blue w/ Yellow Stripe	Throttle Slow; came from Aux Engine Harness pin# 11
9	[empty]	
AUX PLUG IN HARNESS		
1	Yellow	"+" from Ignition; came from Aux Engine Harness pin# 14
2	Black	"-" from Ignition; came from ground on Solenoid
3	Yellow	"+" from Ignition; came from Aux Engine Harness pin# 16
4	Black	"-" from Ignition; came from ground on Solenoid
5	Yellow	"+" from ignition; came form Aux Engine Harness pin# 2
6	Black	"-" from ignition; came from ground on solenoid
7	[empty]	
8	Orange w/ Yellow Stripe	Rocker Switch; came from Aux Engine Harness pin# 5
9	Yellow w/ Orange Stripe	Rocker Switch; came from Aux Engine Harness

Service Section

5.10.5 Engine Rocker Switch Wiring Diagrams

Strobe Light Rocker Switch

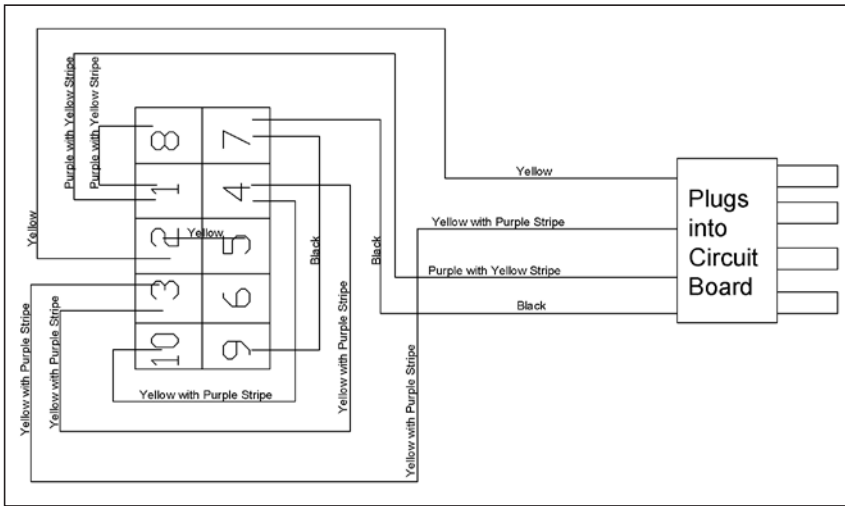

Pin# Color

Description

Pin#	Color	Description
1	Purple w/ Yellow Stripe	“+” Aux from Switch
2	Yellow	“+” from Circuit Board
3	Yellow w/ Purple Stripe	“+” from Strobe Light
4	Yellow w/ Purple Stripe	Looped from #3
5	Yellow	Looped from #2
6		
7	Black	“-” from Circuit Board
8	Purple w/ Yellow Stripe	Looped from #1
9	Black	Looped from #7
10	Yellow w/ Purple Stripe	Looped from #4

Remote Throttle and Remote Clutch Rocker Switch

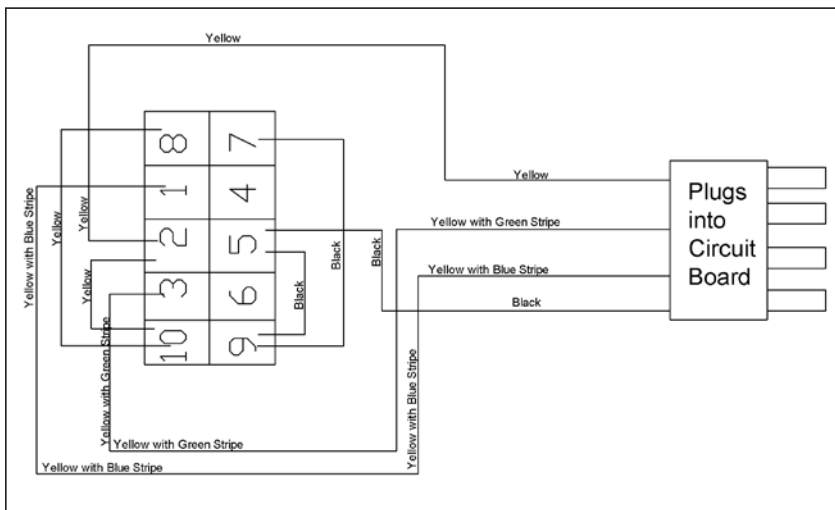

Pin# Color

Description

Pin#	Color	Description
1	Yellow w/ Blue Stripe	Throttle Fast / Clutch Engage
2	Yellow	“+” from Circuit Board
3	Yellow w/ Green Stripe	Throttle Slow / Clutch Disengage
4		
5	Black	“-” from Circuit Board
6		
7	Black	Looped from #9
8	Yellow	Looped from #10
9	Black	Looped from #5
10	Yellow	Looped from #2

This plug is used for the Remote Throttle and the Remote Clutch Rocker Switches.

Caterpillar Engine Heater Rocker Switch

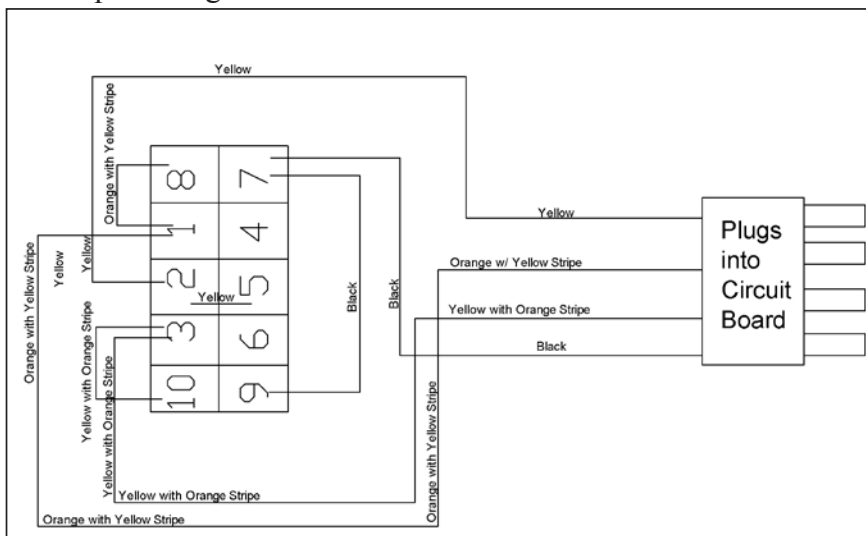

Pin# Color

Description

Pin#	Color	Description
1	Orange w/ Yellow	“+” Aux from Switch
2	Stripe	“+” from Circuit Board
3	Yellow	“+” to Engine Heater
4	Yellow w/ Orange Stripe	
5		Looped from #2
6	Yellow	
7		“-” from Circuit Board
8	Black	Looped from #1
9	Orange w/ Yellow Stripe	Looped from #7
10	Black	Looped from #3

Yellow w/ Orange Stripe

Service Section

5.10.6 Main Circuit Board

TOP LAYER

The circuit board has traces on 2 layers - the top and bottom.

Main Plug Wire ID's

1	+ from Battery (Red)
2	Starter + (Red/Blue)
3	Fuel Sol./Col + (Orange)
4	Ground (Black)
5	Alt Energize + (Purple)
6	Oil Signal (White/Red)
7	Tach Signal (White)
8	E Stop Sig. (Tan/Black)
9	Insp. Door Sig. (Tan)
10	Fuel Level Sig. (Pink)
11	Temp Sig. (Blue)
12	Temp Shtdwn Sig (Blue/Blk)
13	Oil Shutdown Sig. (Red/Blk)

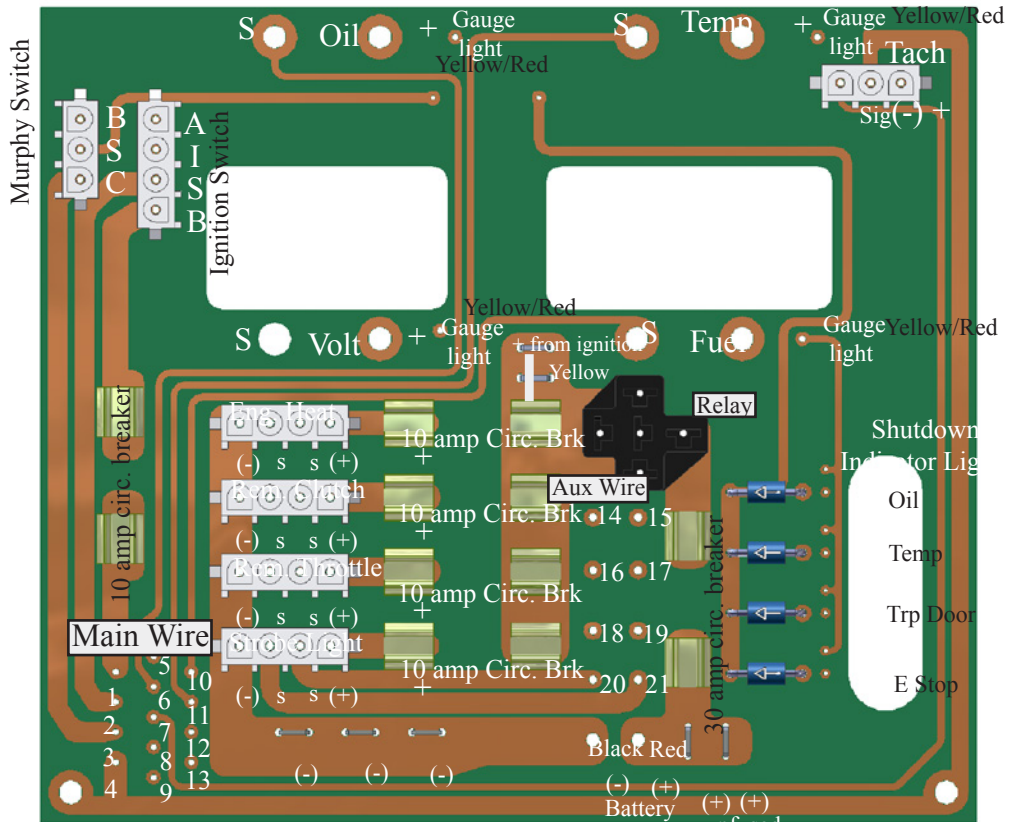

BOTTOM LAYER (looking from the back)

Aux Plug Wire ID's

14	Eng Heat (+) (Yellow/Orange)
15	Eng. Heat Aux (Orange/Yellow)
16	Clutch Engage (Yellow/Green)
17	Clutch Disengage (Green/Yel)
18	Throttle Fast (Yellow/Blue)
19	Throttle Slow (Blue/Yellow)
20	Strobe Light + (Yellow/Purple)
21	Aux Light + (Purple/Yellow)

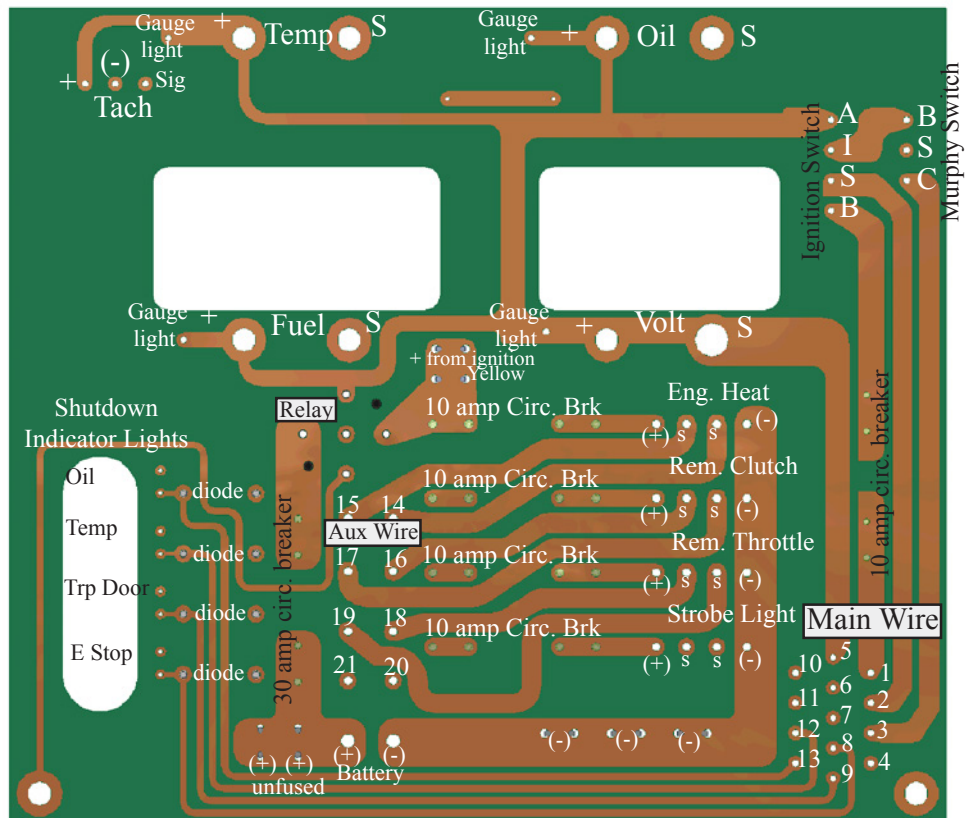

Service Section

5.10.7 Main Circuit Board Plug Diagrams

Main Harness Plug

Pin# Description

1	Red + from battery
2	Red / Blue stripe - starter +
3	Orange - Fuel Sol./Col +
4	Black - Ground
5	Purple Alt Energize +
6	White / Red stripe Oil Signal
7	White - Tach Signal
8	Tan / Black stripe E Stop Sig.
9	Tan - Insp. Door Signal
10	Pink - Fuel Level Signal
11	Blue - Temp Signal
12	Blue/Black Temp Shtdwn Sig
13	Red/Black Oil Shutdown Sig.
14	Empty
15	Empty
16	Empty

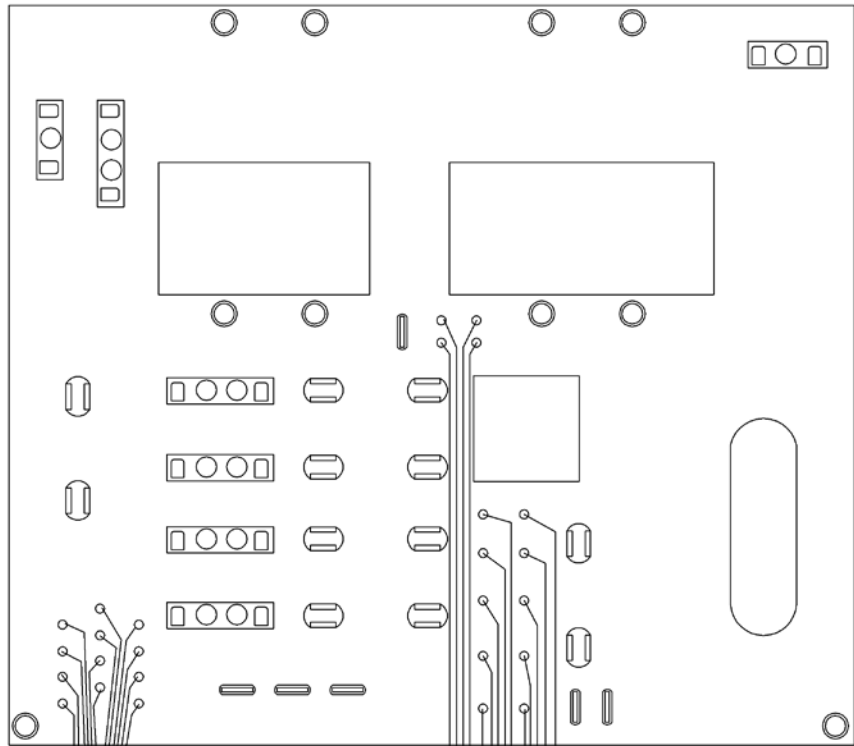

Aux. Harness Plug

Pin# Description

1	Red + from battery
2	Yellow - Aux Plug harness
3	Yellow - Remote Throttle Har
4	Yellow / Orange stripe-Aux har
5	Orange / Yellow stripe-Aux har
6	Yellow / Green stripe-Clutch Eng
7	Empty
8	Green / Yellow stripe-Clutch Diseng
9	Yellow / Blue stripe-Throttle Fast
10	Empty
11	Blue / Yellow stripe-Throttle Slow
12	Yellow / Blue stripe-Strobe +
13	Purple / Yellow stripe-Strobe Sw+
14	Yellow - Aux Harness
15	Black - battery
16	Yellow - Aux Harness

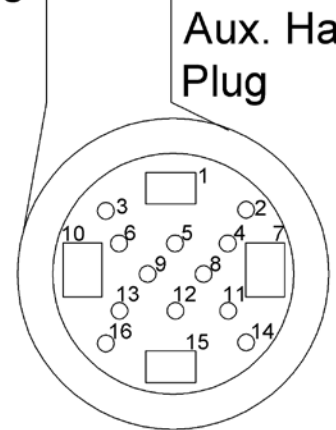
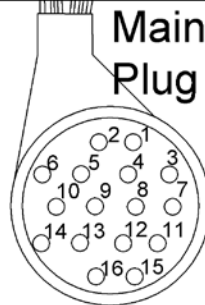

Service Section

5.10.8 Trailer Plug Wiring Diagram

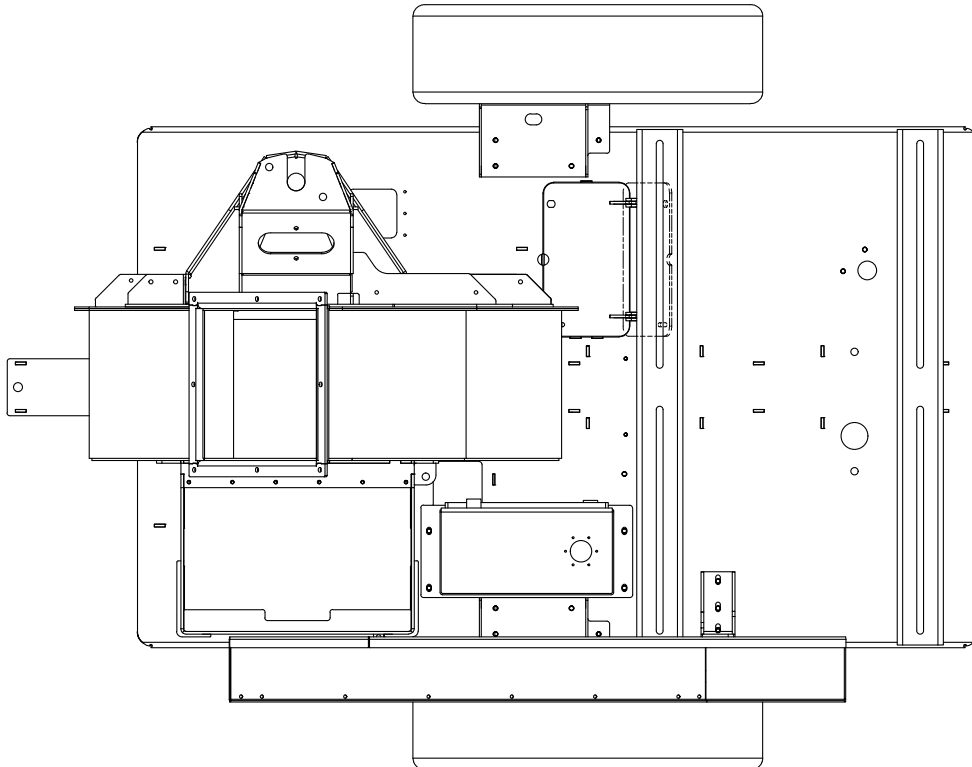
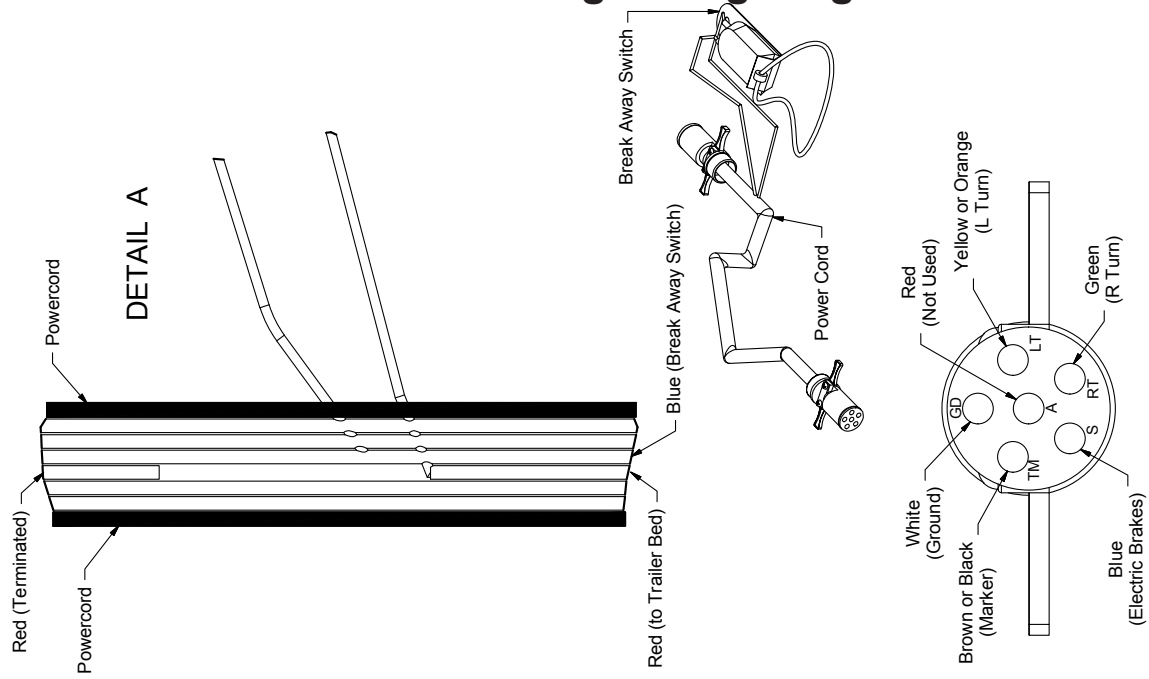

Service Section

5.10.9 Trailer Wiring Harness

TRAILER WIRING HARNESS

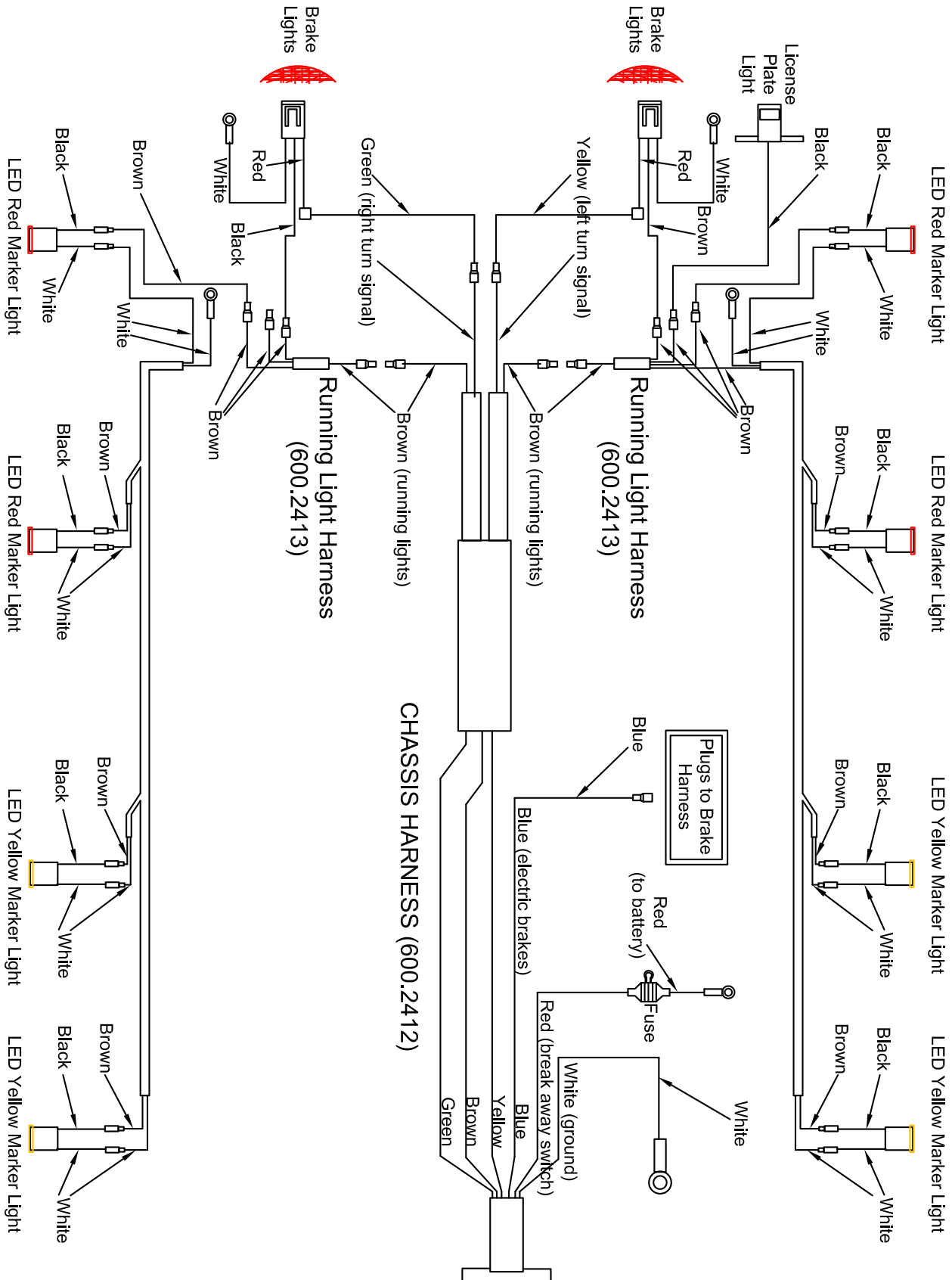

Service Section

5.10.10 Brake Wiring Harness

BRAKE HARNESS (600.613)

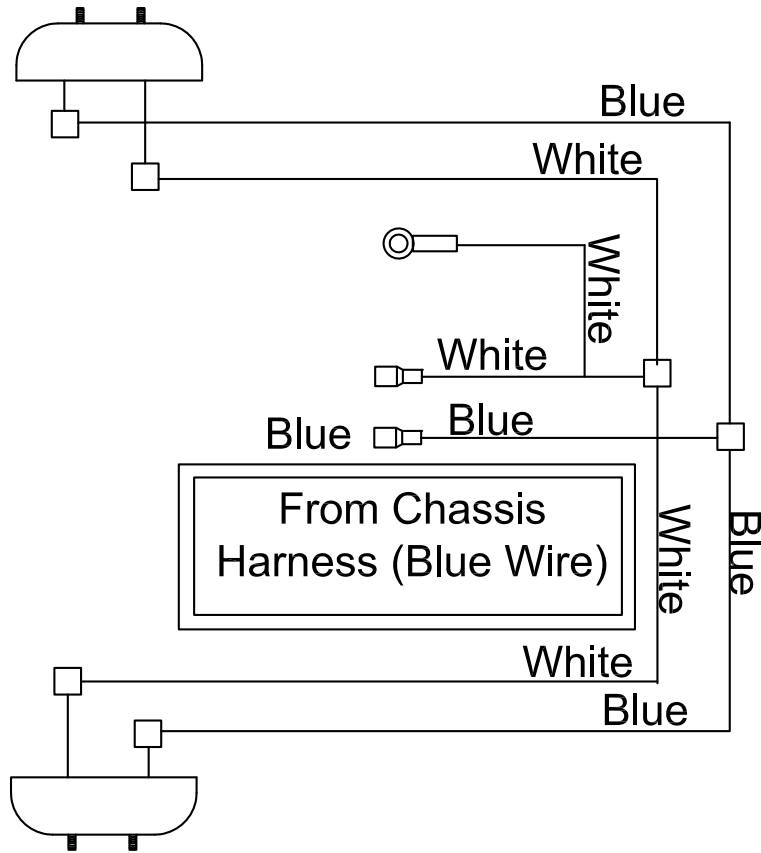

Service Section

5.10.11 Boom Wiring Diagram

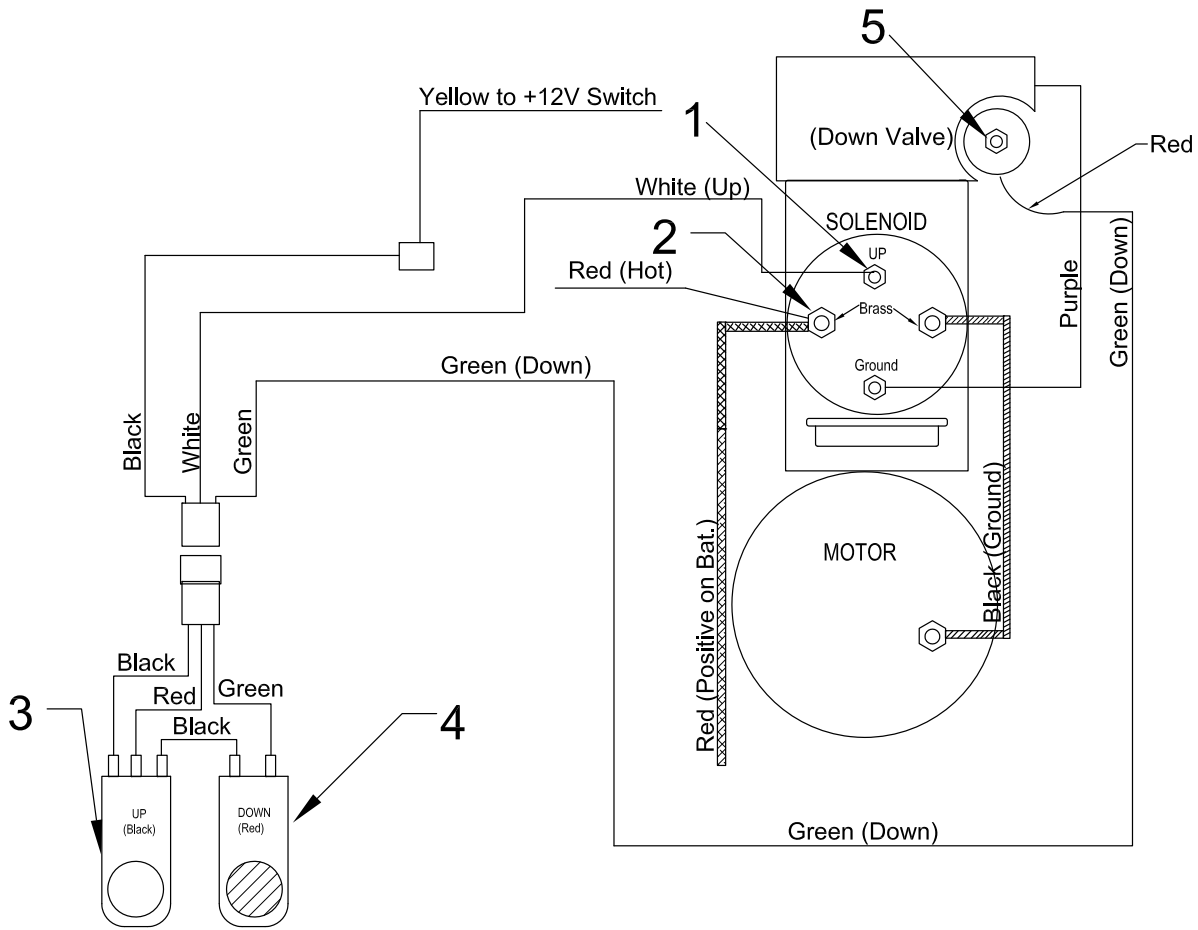

COLOR	FUNCTION
Green	Down
White	Up
Purple	Ground on Solenoid
Red (4 gauge cable)	Positive to Battery
Black (4 gauge cable)	Ground from Solenoid to Hydraulic Motor
Black (from up down switch)	changes to Yellow - Positive for Boom Rocker Switch on instrument panel (if equipped)

Service Section

5.10.12 Remote Throttle / Clutch Wiring Harness

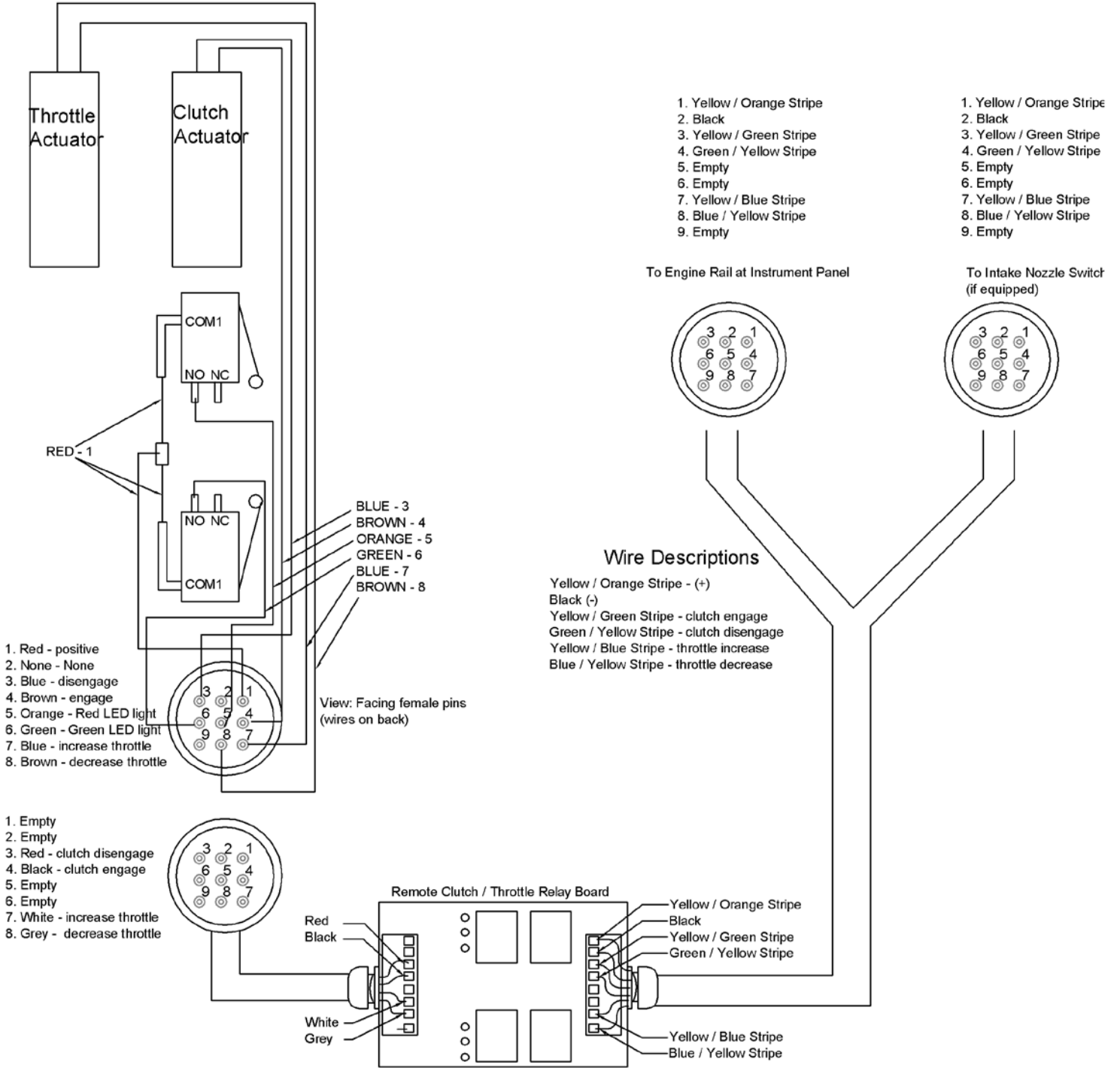

Service Section

5.20.1 Wiring Harness Diagram 2 Section Valve Body - 2 Axis

* Every connector has 2 wires, one is a (color), the other is black

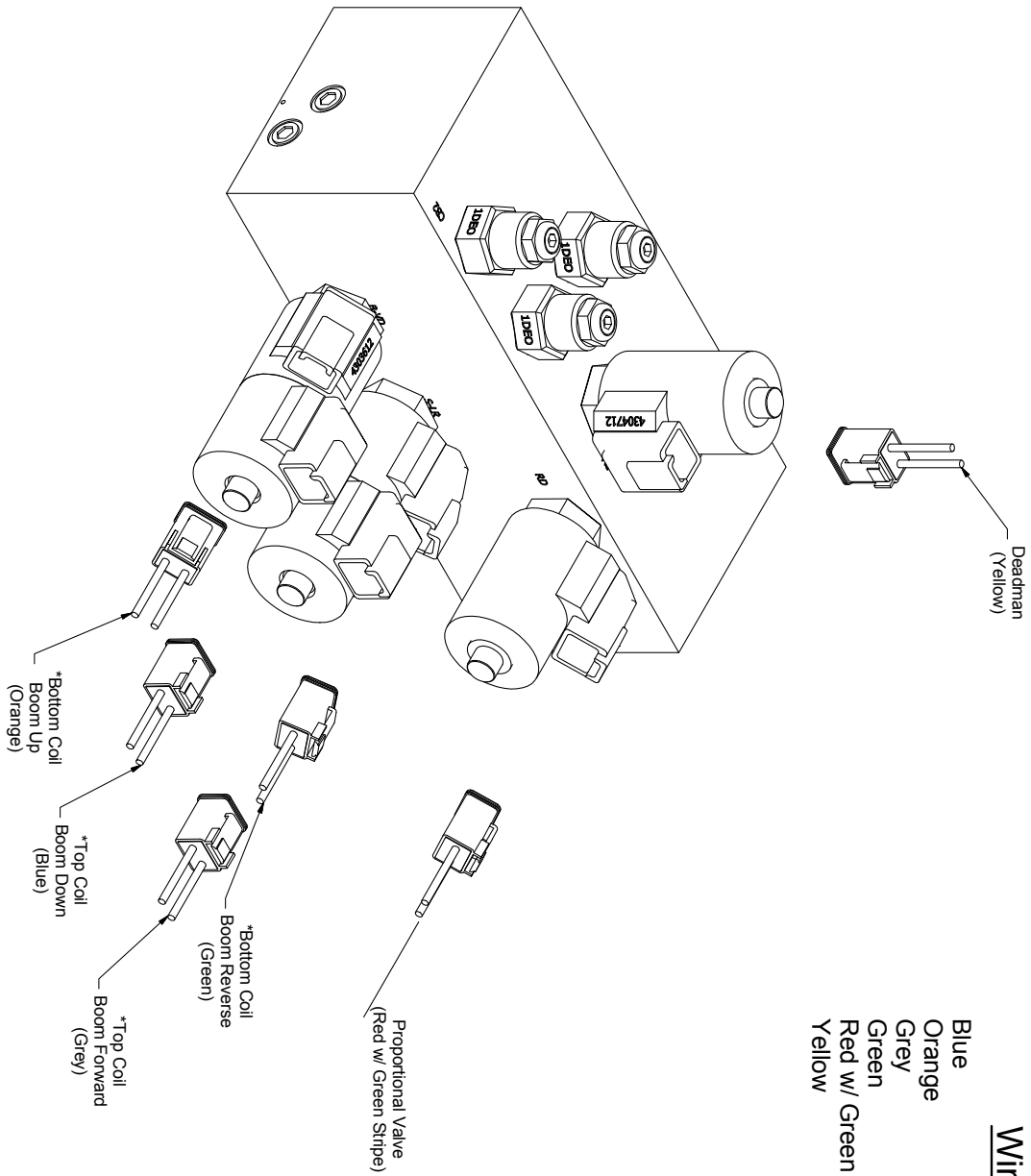

- Blue
- Orange
- Grey
- Green
- Red w/ Green Stripe
- Yellow

Wiring Diagram

- Boom Down
- Boom Up
- Boom Forward
- Boom Reverse
- Proportional Valve
- Deadman

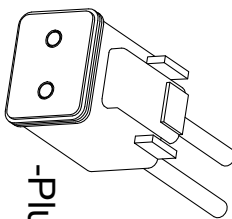

-Plug Connector

Service Section

5.20.2 Wiring Harness Diagram 4 Section Valve Body - 3 Axis

* Every connector has 2 wires, one is a (color), the other is black

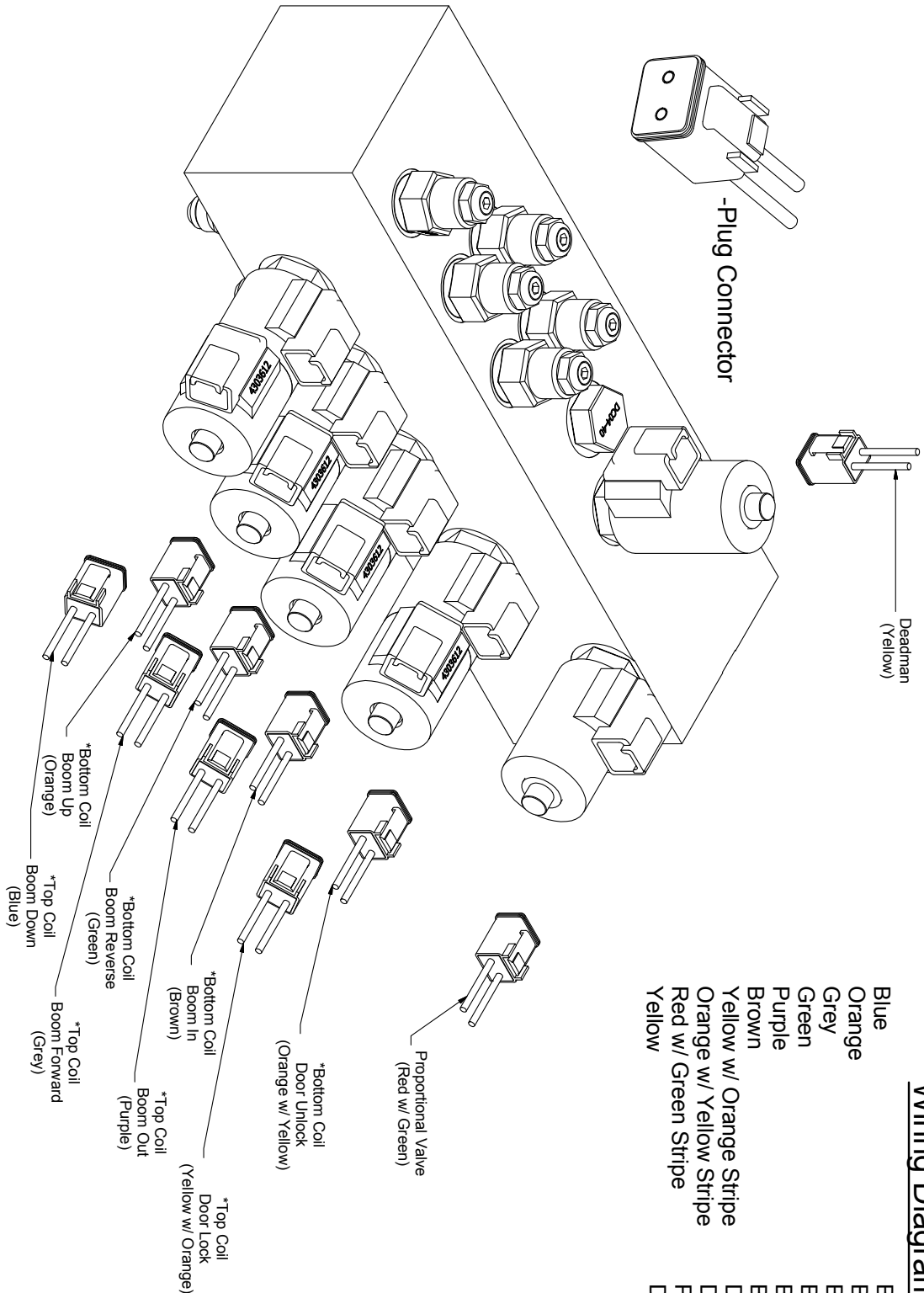



PARTS BREAKDOWNS SECTION

**Engine Group
Clutch Group
Blower Housing Group
Trailer Group
Hose Boom Group**

PARTS BREAKDOWN SECTION

ODB COMPANY
5118 Glen Alden Drive
Richmond, VA 23231
800-446-9823



6-0

6.0 ENGINE GROUP

6.0 ENGINE GROUP

6-0	75
6.1 Instrument Panel Group	76
6.2 Air Cleaner Group.....	77
6.3 Strobe Light Parts Group	78
6.4 Sheet Metal Group	79
6.5 Engine Mount Group	80
6.6 Muffler (Exhaust) Assembly	81
6.7 Radiator Assembly Group.....	82
6.8 Engine Senders / Switch Group	83
6.9 John Deere Common Engine Parts Group	84
6.10 Battery Group.....	85
6.11 Engine Miscellaneous Parts Group.....	86
6.12 Remote Clutch / Throttle Circuit Board Assembly.....	87
6.13 Remote Clutch and Remote Throttle Assembly.....	88
6.14 Chaffe Eliminator Assembly, hinged	89

ENGINE GROUP

ODB COMPANY
5118 Glen Alden Drive
Richmond, VA 23231
800-446-9823

6.1 Instrument Panel Group

Standard units Nov 2008 and after

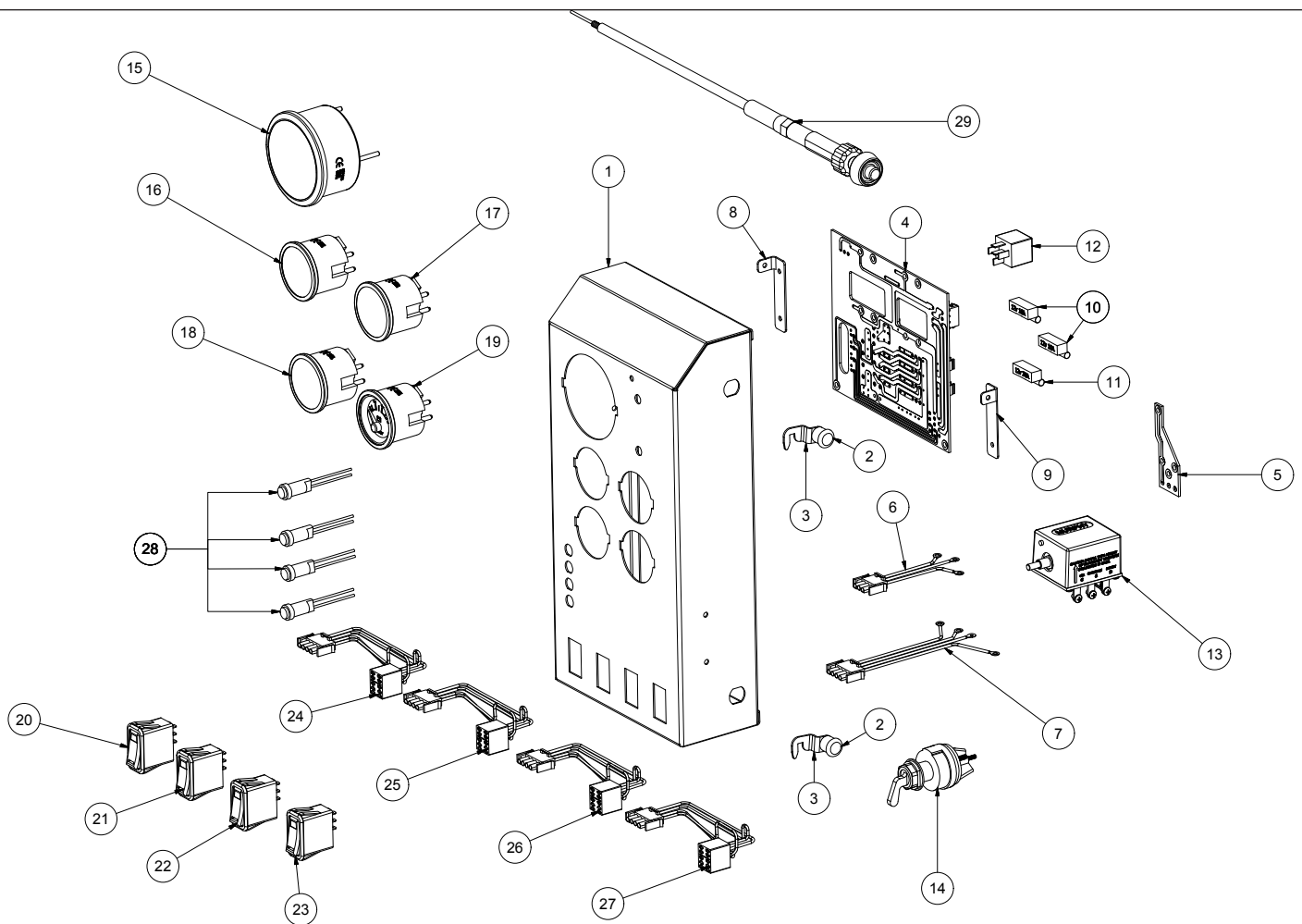

ITEM#	PART NO.	DESCRIPTION
1	STD.6300 STD.6301	Instrument Panel Complete Inst. Panel Housing with latches
2	STD.6308	Latch
3	STD.6309	Latch Hook
4	STD.2005	Circuit Board
5	STD.2006	Tachometer Circ. Board
6	400022	Murphy Swith Harness Plug
7	400021	Ign. Switch Harness Plug
8	STD.6303	Circ. Brd Supp Brkt, LH
9	STD.6302	Circ. Brd Supp Brkt, RH
10	100014.10	Circuit Breaker, 10 amp
11	30410.30	Circuit Breaker, 30 amp
12	VF4-15F11	Relay
13	MO-P81505	Murphy Switch
14	31.253	Ignition Switch

ITEM#	PART NO.	DESCRIPTION
15	63524	Tachometer / Hour Meter
16	62540	Temperature Gauge
17	62542	Oil Pressure Gauge
18	62551 59414	Fuel Gauge (if equipped) Blank Gauge
19	62555	Volt Meter
20	4045.0021B1	Rocker Switch,Safety Light
21	4045.0021A1	Rocker Switch, Rem. Thrttle
22	4045.0025A	Rocker Switch, Rem. PTO
23	3054.0028.	Rocker Switch, Engine Heat
24	STD.2003	Switch Harness, Light
25	STD.2004	Switch Harness, Rem Thrtle
26	STD.2004	Switch Harness, Rem PTO
27	STD.2002	Switch Harness, Eng Heat
28	STD.1502B	LED Light Assembly
29	LCT623.001A	Throttle Cable

6.2 Air Cleaner Group

John Deere Engines

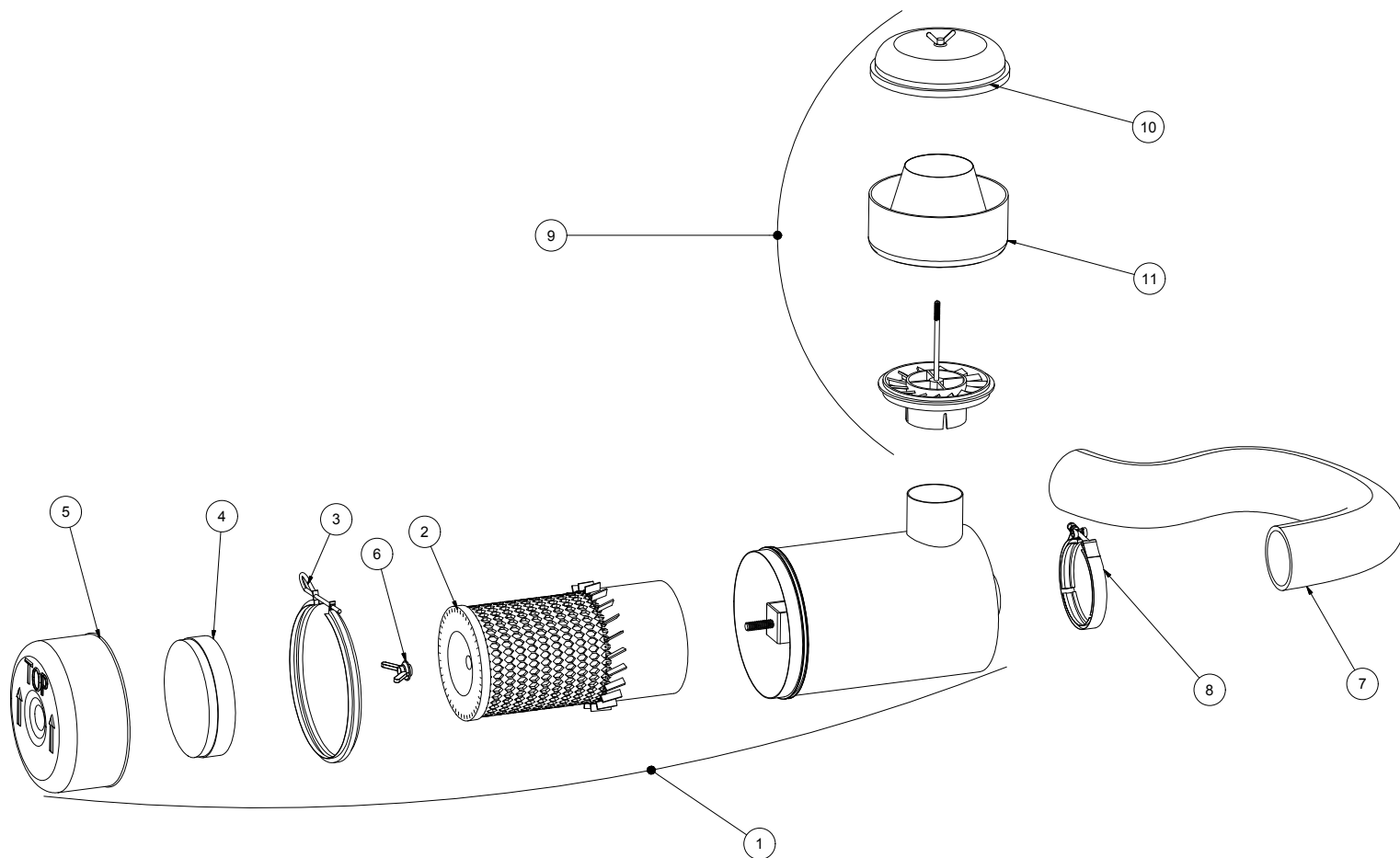

ITEM #	PART NUMBER	DESCRIPTION
1	UU-G080023	Air Cleaner Assembly
2	UU-P18.1054	... Filter Element
3	... P003951	... Clamp
4	... P102980	... Rubber Baffle
5	... P103113	... Dust Cap
6	... P101870	... Wing Nut
7	STD.2704	Rubber Elbow
8	P004307	Mounting Bands (to sheet metal)
9	H001249	Pre-Cleaner
10	UU-P02.0648	... Bowl Cover
11	UU-P02.0227	... Bowl

6.3 Strobe Light Parts Group

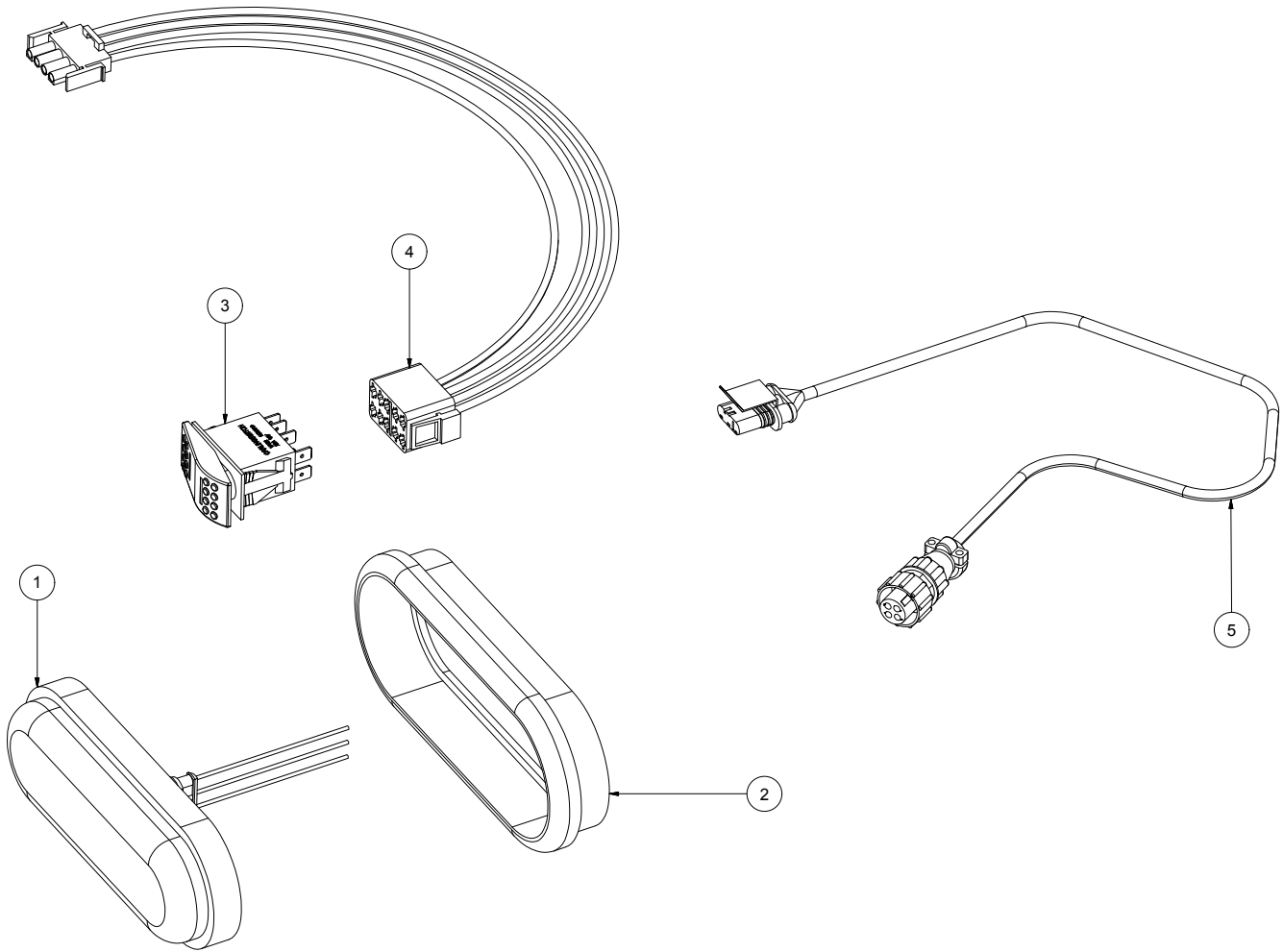

ITEM #	PART NUMBER	DESCRIPTION
1	STD.2213	LED Strobe Light
2	60700	Grommet
3	4045.0021B1	Rocker Switch
4	4045.0024B	Switch Wiring Harness
5	STD.2214	Wiring Harness, rocker switch to light.

6.4 Sheet Metal Group

John Deere 4045T and 6068D June 2005 and after

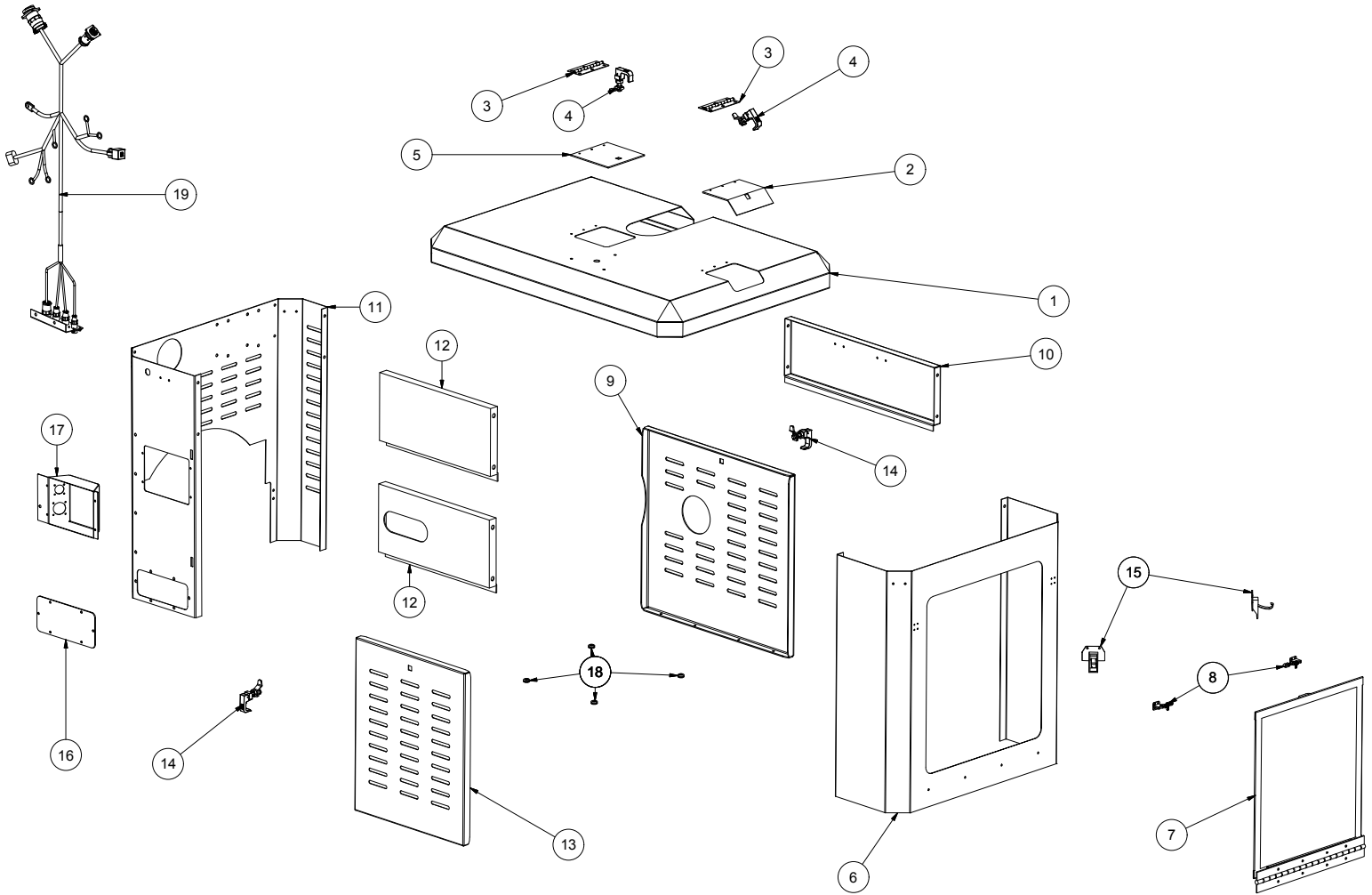

ITEM#	PART NO.	DESCRIPTION
1	4045T.2102	Hood, not SCL
2	4045.2102A	Radiator Access Door
3	4045.2102C	Radiator Access Door Hinge
4	LCT60.624A	Lift and Turn Latch
5	4045.2102B	Oil Fill Access Door
6	4045.2101	Front Panel
7	4045.0018	Radiator Screen
8	LCT650.114	Radiator Screen Clamp
9	4045.2109	Panel Door, LH
10	4045.2106A	Upper Side Panel, LH
11	4045.2112C	Rear Panel, NOT SCL

ITEM#	PART NO.	DESCRIPTION
12	4045.2105A	Upper Side Panel, RH
*	4045.2105	*No Hole/Slot ; LCT60C*
13	4045.2108	Panel Door, RH
14	LCT60.624A	Lift and Turn Latch
15	LCT609.602	Overcenter Latch
16	4045.2112F	Cover, Solenoid
17*	STD.6304	Wiring Plug Bracket
18	2856.26012	Door Grommet
19*	4045.2001	Engine Harness, Dual Panel Plug

* #19 comes with #17 attached/installed, but #17 can be bought individually without harness

6.5 Engine Mount Group

John Deere 4045D, 4045T and 6068D after 08/96

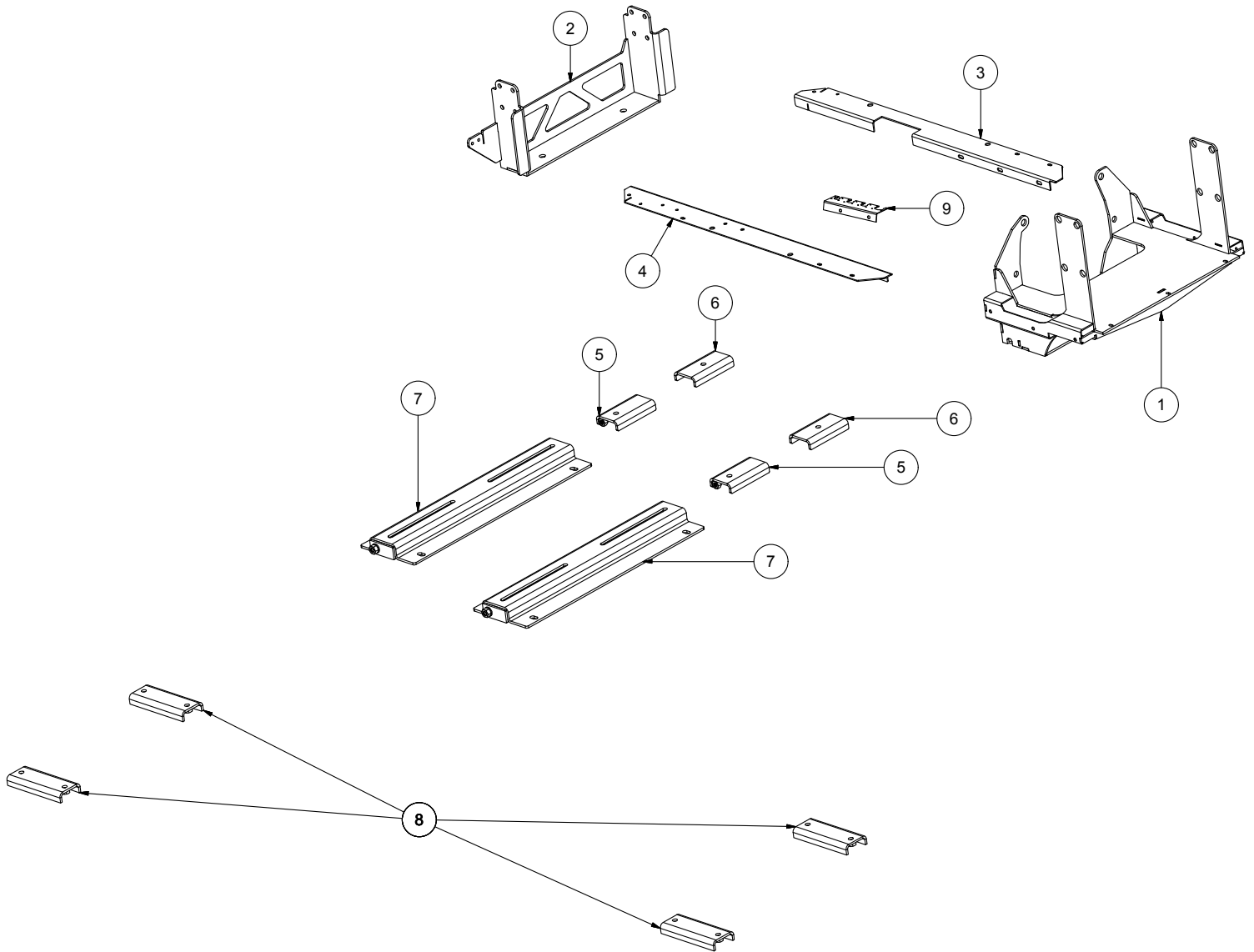

ITEM #	PART NUMBER	DESCRIPTION
1	4045.2151A	Engine Mount, Front
2	4045.2152	Engine Mount, Rear
3	4045.2154	Side Rail, LH, except LCT650
4	4045.2153	Side Rail, RH
5	LCT604.603.1	Engine Adjuster Nut
6	LCT604.603.1A	Engine Adjuster Bracket
7	LCT604.603.2	Adjustable Motor Mount
8	LCT604.603.B	Engine Base Adjuster
9	4045.2155	Wiring Harness Bracket

6.6 Muffler (Exhaust) Assembly

LCT's only with John Deere engines (not SCL's) May 2004 and after

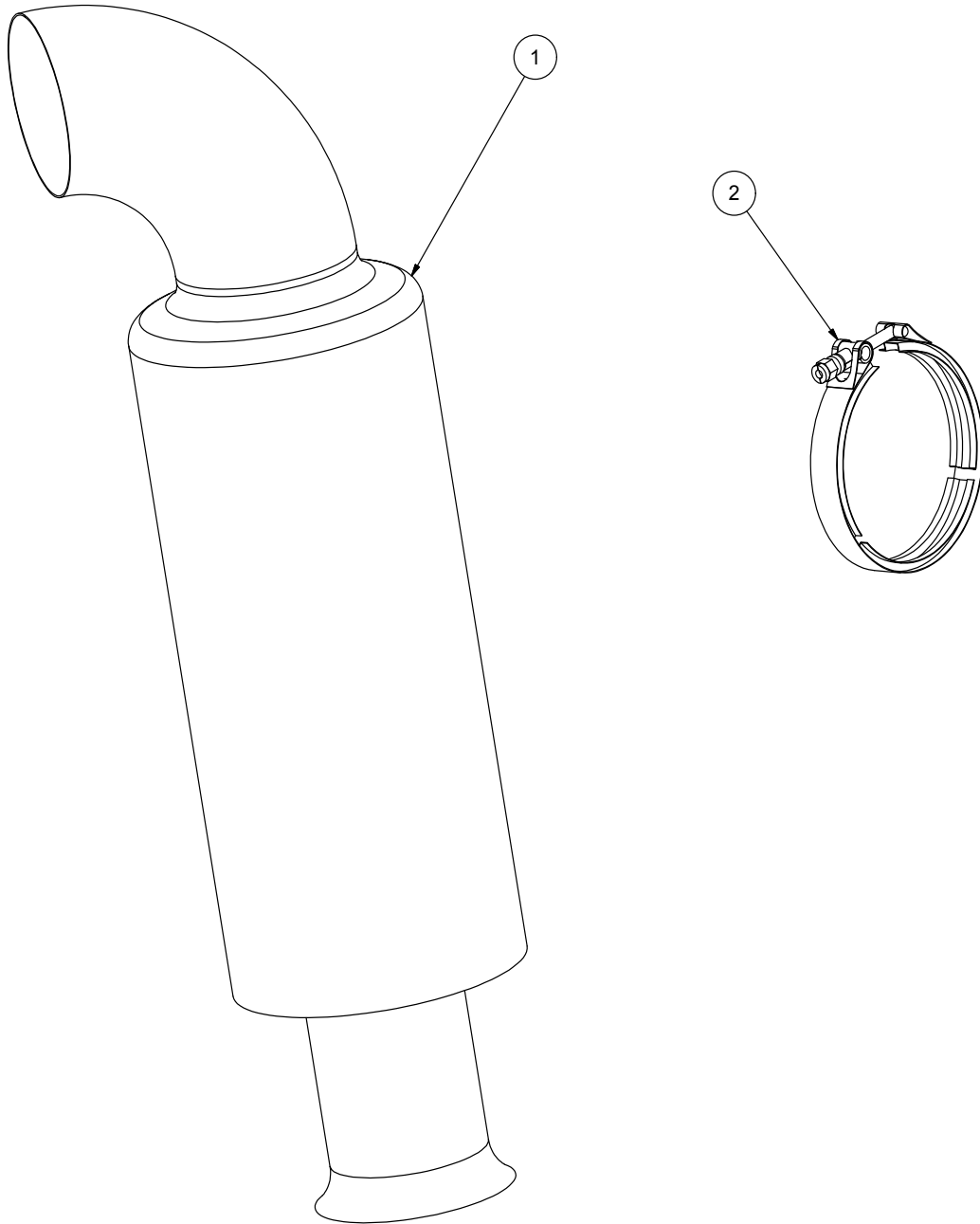

ITEM #	PART NUMBER	DESCRIPTION
1.	650.2701	Muffler
2.	STD.2702	Clamp, muffler

6.7 Radiator Assembly Group

John Deere after August 1996

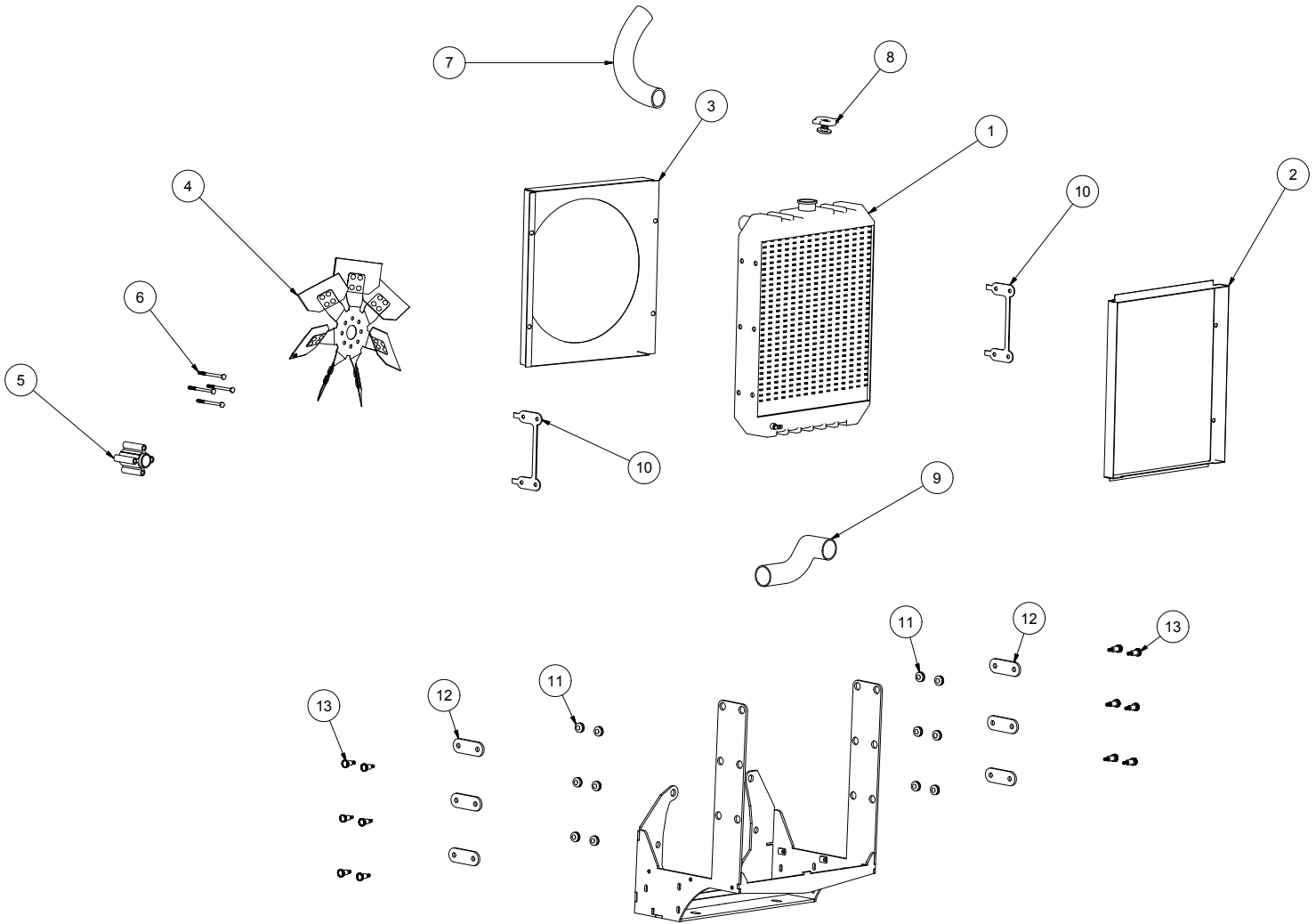

ITEM#	PART NO.	DESCRIPTION
1	4045.9501A1	Radiator
2	4045.2190B	Front Fan Shroud
3	4045.2190A	Rear Fan Shroud
4	AT35158.A	Radiator Fan
5	R128443	Fan Spacer
6	G8M8X090	Spacer Bolts, 4 required
7	81331	Upper Radiator Hose

ITEM#	PART NO.	DESCRIPTION
8	10300	Radiator Cap
9	4045.9681	Lower Radiator Hose
10	4045.2151E1	Radiator Shim
11	H9601	Radiator Grommet
12	4045.2151F	Radiator Bolt Bracket
13	ZSB.500.750	Shoulder Bolt

6.8 Engine Senders / Switch Group

John Deere Engines

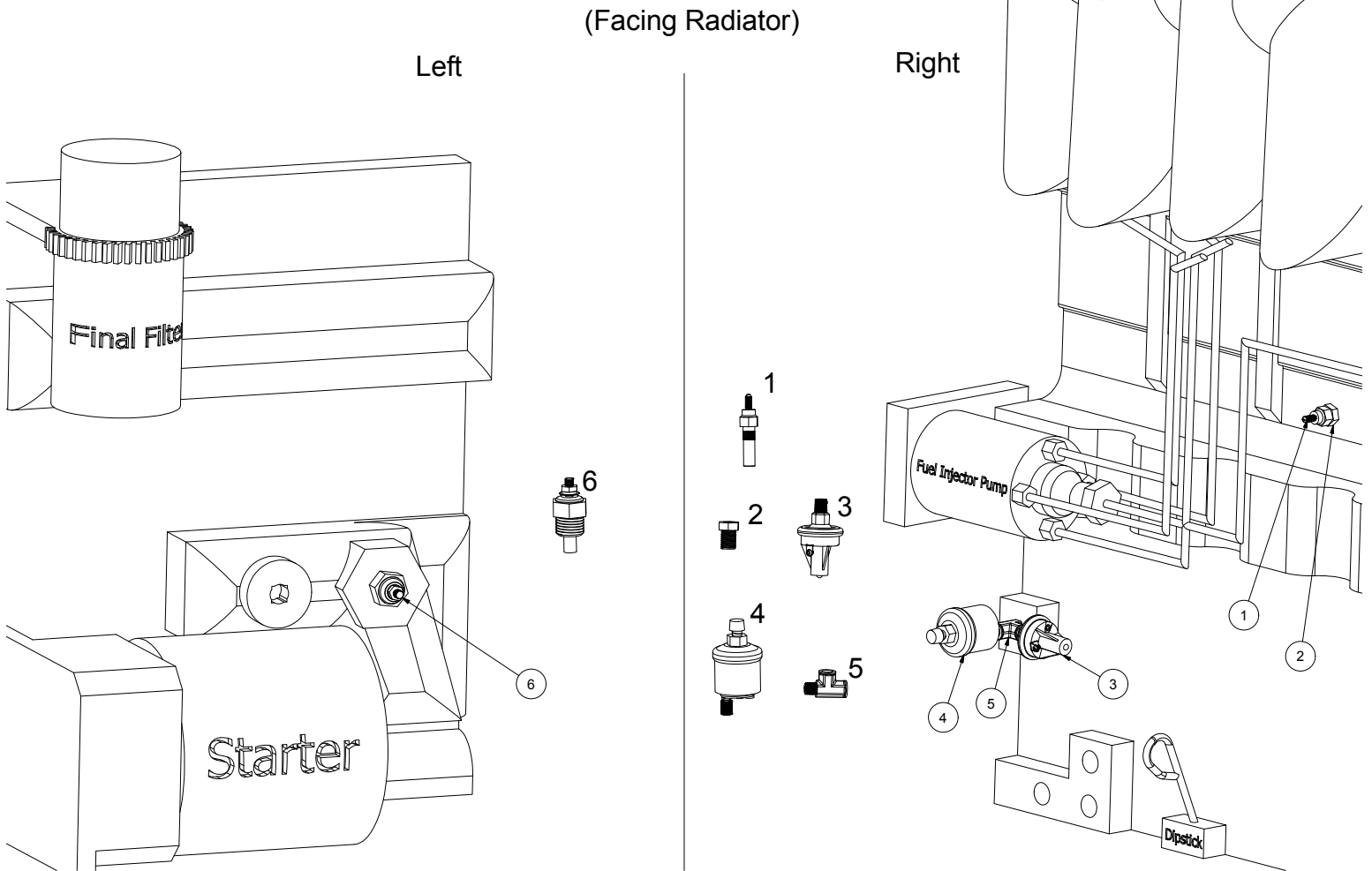

ITEM #	PART NUMBER	DESCRIPTION
1.	35423.049	Water Temperature Switch
2.	C5104.4.2	Fitting for Water Temperature Switch
3.	9603273	Oil Pressure Switch
4.	1500171	Oil Pressure Sender
5.	3750.2*	Bushing for Oil Pressure Switch and Sender
6.	52320.009	Water Temperature Sender

6.9 John Deere Common Engine Parts Group

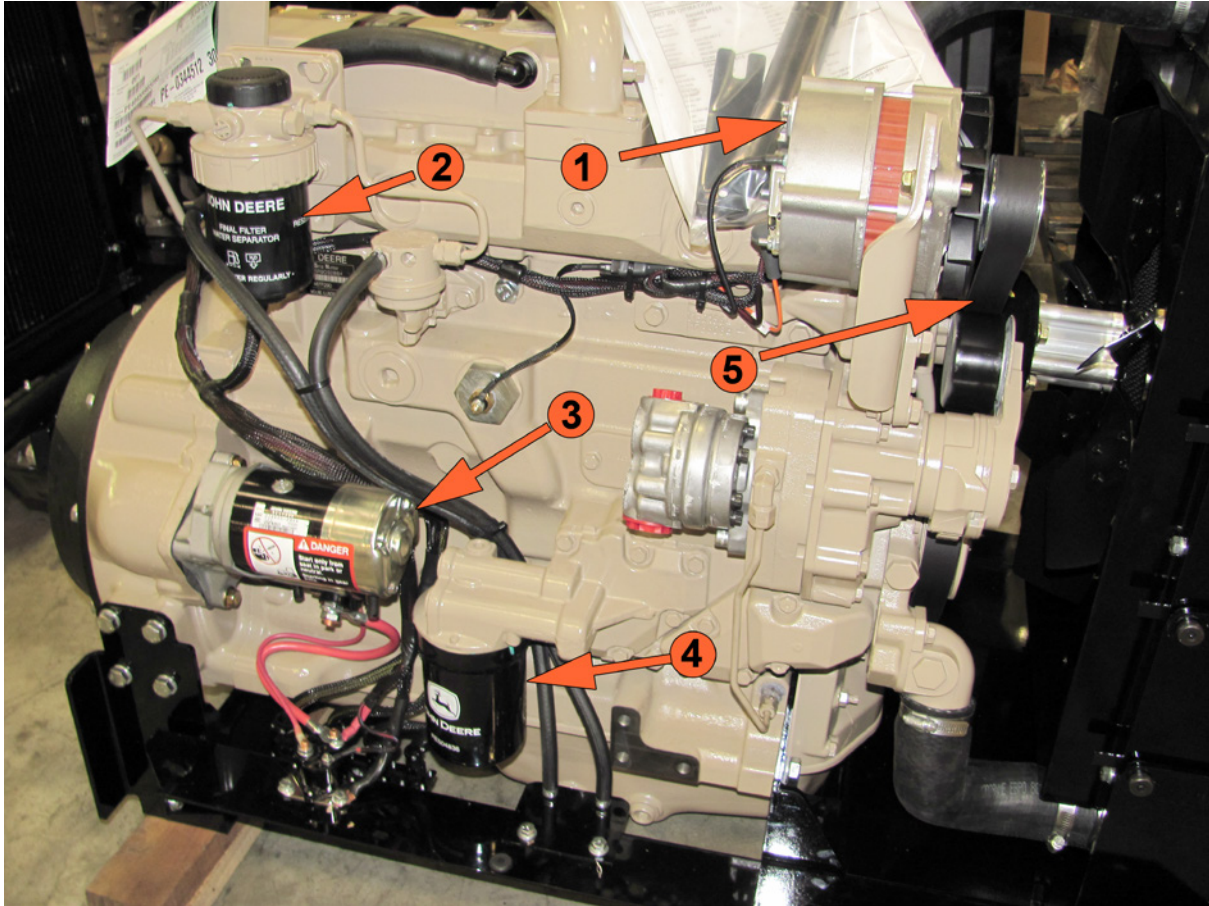

ITEM #	PART NUMBER	DESCRIPTION
1	JD-RE533516	Alternator
2	JD-RE522868	Fuel Water Separator
3	JD-RE59588	Starter Motor
4	JD-RE504836	Oil Filter
NS	JD-R502513	O-Ring for Oil Filter
5	JD-R123438	Serpentine Belt

6.10 Battery Group

Standard units 2001 and after

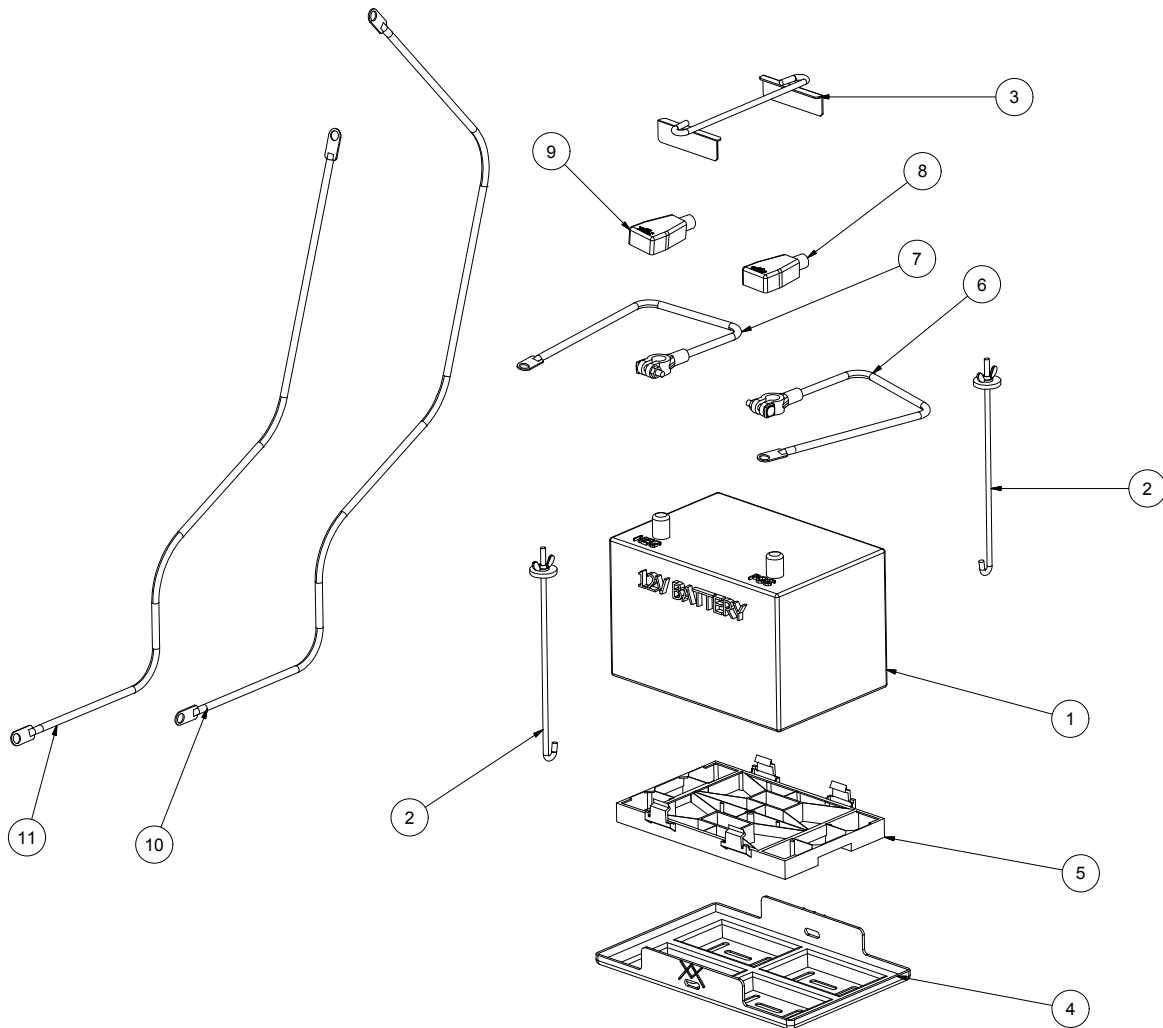

ITEM #	PART #	DESCRIPTION
1.	STD.2200	Battery, not shippable
2.	BHB10J	J-Hook
3.	BHCB	Battery Hold Down Bar
4.	BTS1	Battery Tray, all but SCL's
5.	N/A	N/A
6.	SCL.42B	Positive Battery Cable, Battery to Solenoid - LCT60C/650- 42" long
	LCT600.84B	Positive Battery Cable, Battery to Solenoid - LCT600/6000 - 84" long
7.	LCT60.15B	Negative Battery Cable, all - 15" long
8.	BTC.R	Terminal Cover, Red, all
9.	BTC	Terminal Cover, Black, all
10.	LCT600.72SS MET.60SS LCT60C.153SS	Red Cable to Hydraulic Boom Pump, SCL/600/6000 - 72" long Red Cable to Hydraulic Boom Pump, LCT650, 60" long Red Cable to Hydraulic Boom Pump, LCT60C, 153" long
11.	LCT600.24SS	Ground (Black) Cable to Chassis, 600/6000/60C - 24"

6.11 Engine Miscellaneous Parts Group

John Deere Engines

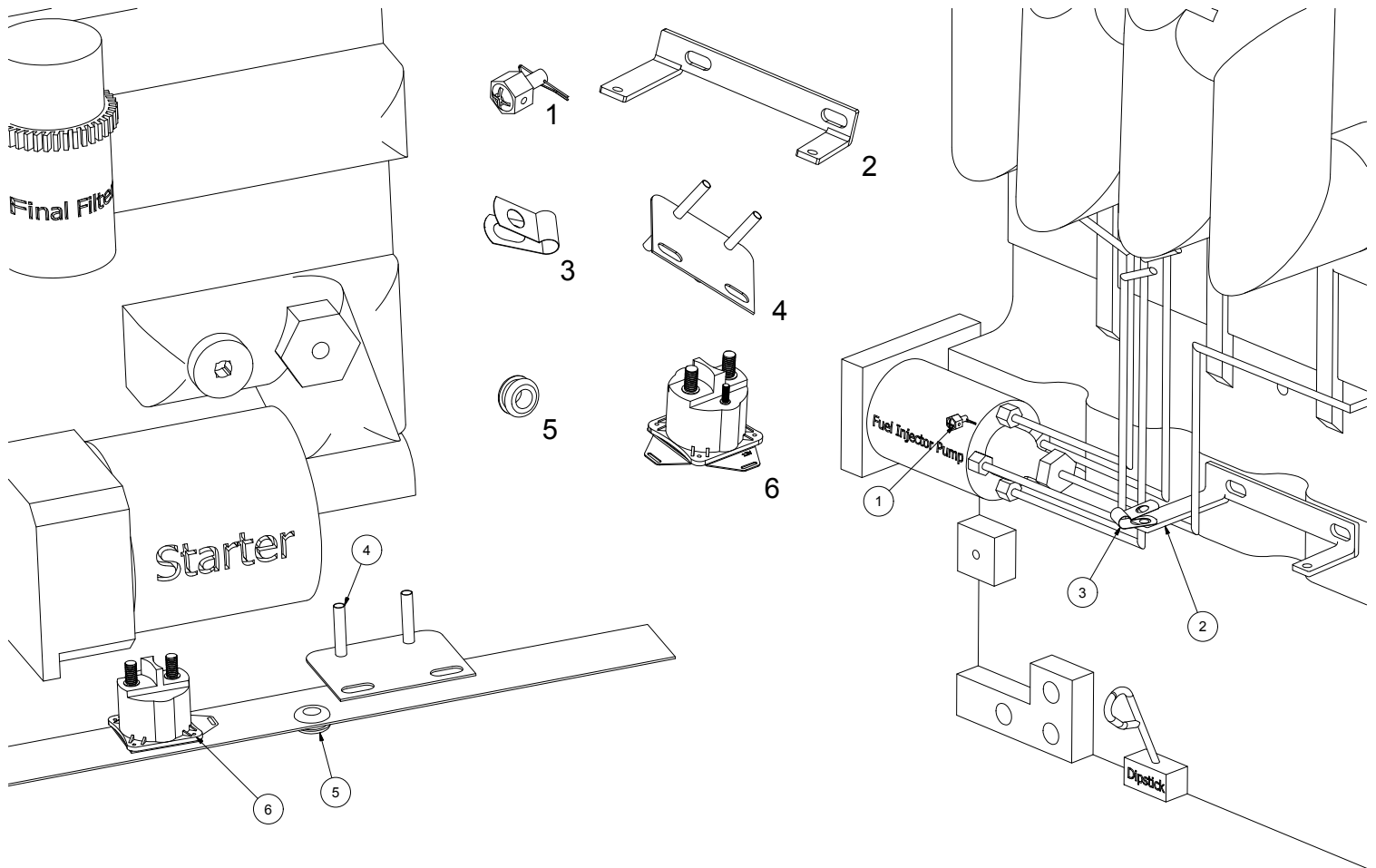

ITEM #	PART NUMBER	DESCRIPTION
1	JD6125B	Throttle Connector
2	4045.9101	Throttle Cable Bracket, LCT
3	4045T.9101A	Throttle Cable Clamp
4	400016	Fuel Line Bracket
5	2856.26012	Grommet - Door
6	ST40	Starter Solenoid

6.12 Remote Clutch / Throttle Circuit Board Assembly

October 2005 and after with remote throttle / clutch option

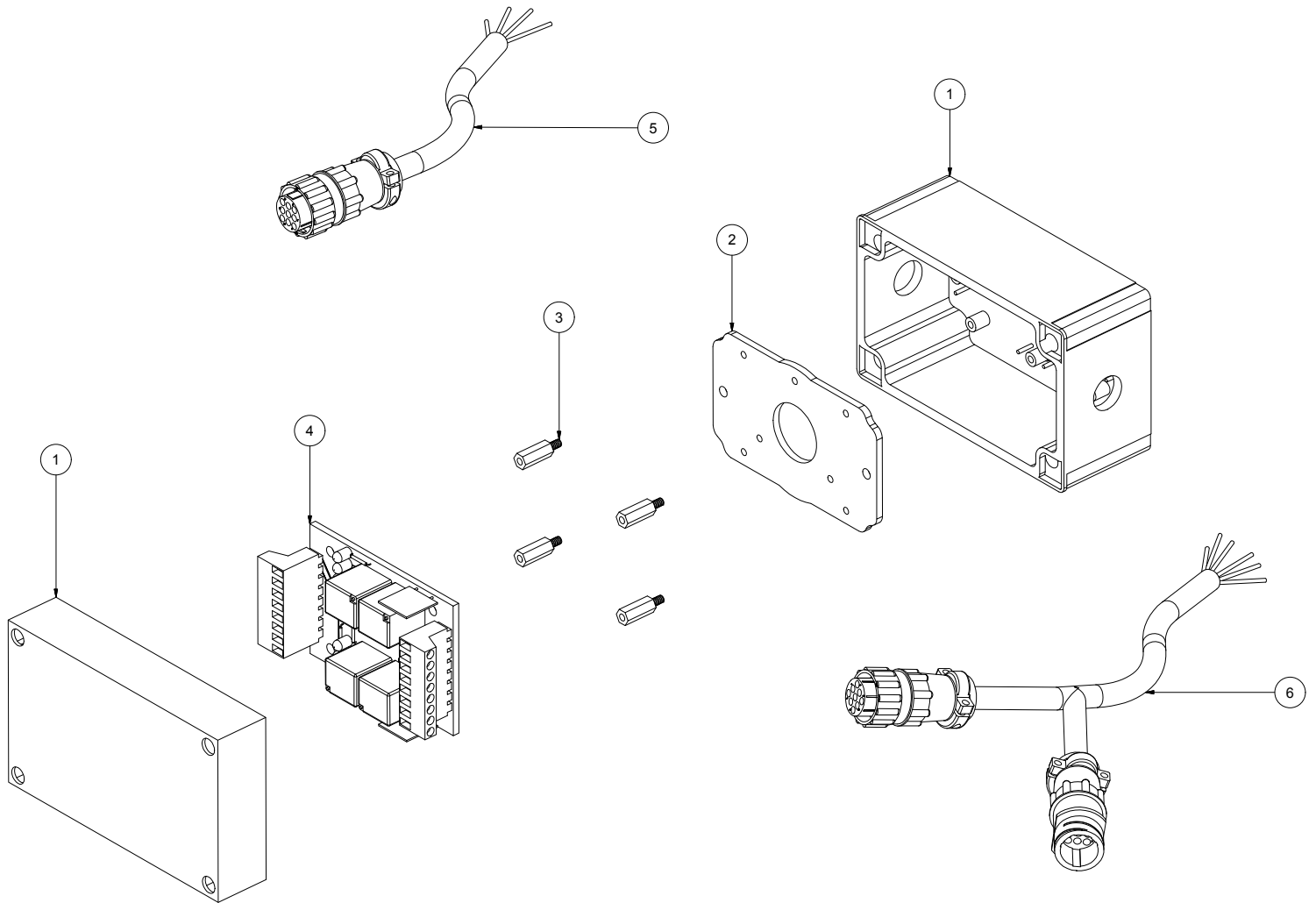

ITEM #	PART NUMBER	DESCRIPTION
*	STD.3000	Entire Assembly
1	only available as an assembly	Box and Cover
2	only available as an assembly	Backing Plate
3	only available as an assembly	Spacer, rquires 4
4	only available as an assembly	Circuit Board
5	only available as an assembly	Actuator Wiring Harness
6	only available as an assembly	Instrument Panel and Nozzle Wiring Harness

6.13 Remote Clutch and Remote Throttle Assembly

after March 2002- ver. 2

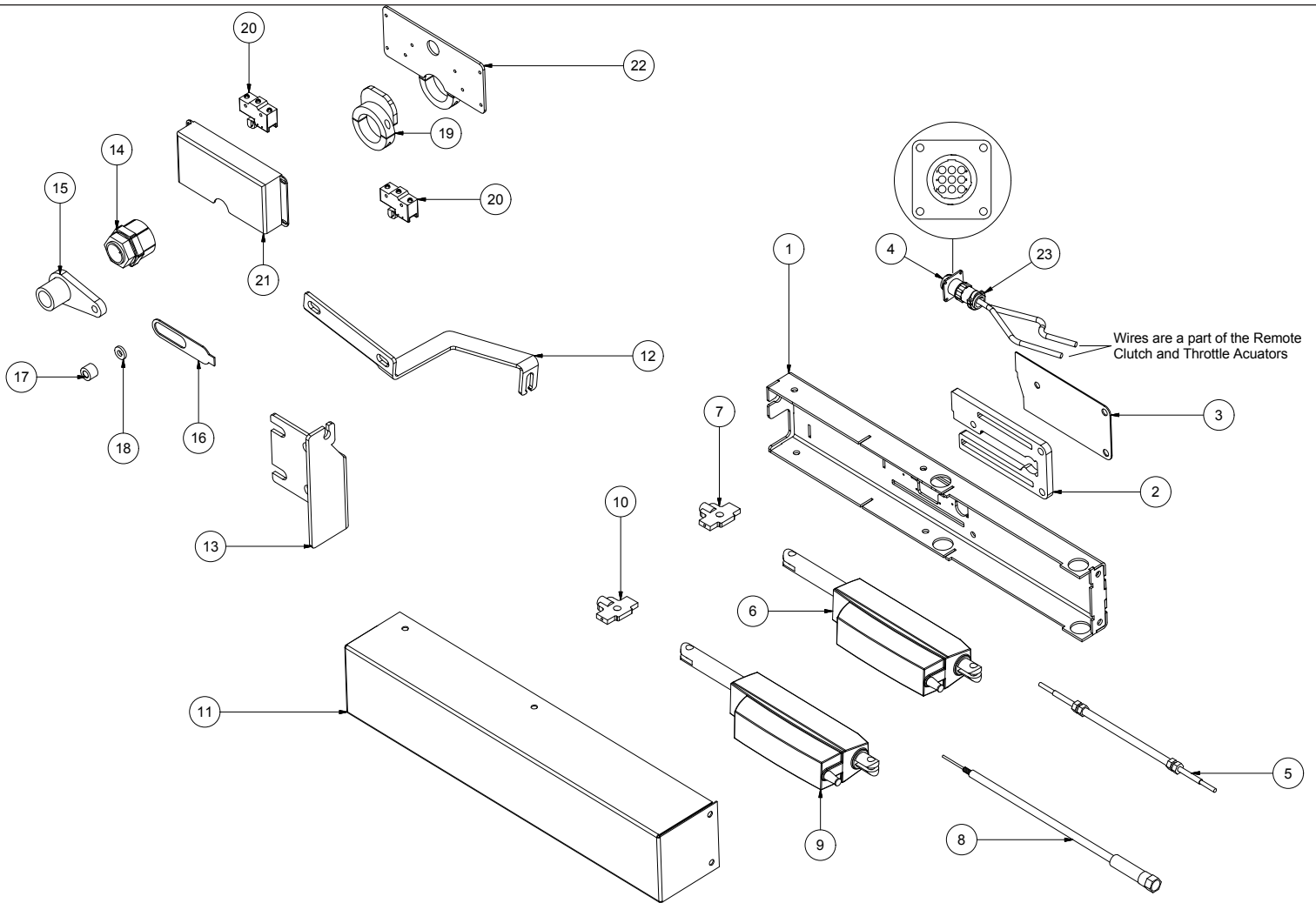

ITEM #	PART NO.	DESCRIPTION
	STD.6550B	Entire Assembly
1	STD.6551A	Mounting Base
2	STD.6551A.01	Thick Spacer
3	STD.6551A.02	Thin Spacer
4	STD.2919	CPC Plug, 9 Pin
5	STD.6554 STD.6554B	Clutch Cable - Direct Drive Clutch Cable - Belt Drive
6	STD.6556	Clutch Actuator (top)
7	STD.6559	Cable Adaptor - clutch
8	STD.6553 STD.6553B	Throttle Cable - direct drive Throttle Cable - belt drive
9	STD.6557	Throttle Acuator (bottom)
10	STD.6558	Cable Adaptor-throttle

ITEM #	PART NO.	DESCRIPTION
11	STD.6552A	Cover
12	4045.6565	Throttle Cable Bracket
13	4045.6564	Clutch Cable Bracket
14	STD.6563	Torque Coupling
15	STD.6562	Coupling Sleeve
16	STD.6560	PTO Cable Adaptor
17	STD.6561	Roller Bearing
18	STD.6568	Spacer Washer
19	STD.6569	Collar Cam (3x only)
20	800.433	Limit Switch (3x only)
21	STD.6571	Cover
22	STD.6570	Limit Switch Bracket
23	STD.2916	CPC Housing

6.14 Chaffe Eliminator Assembly, hinged

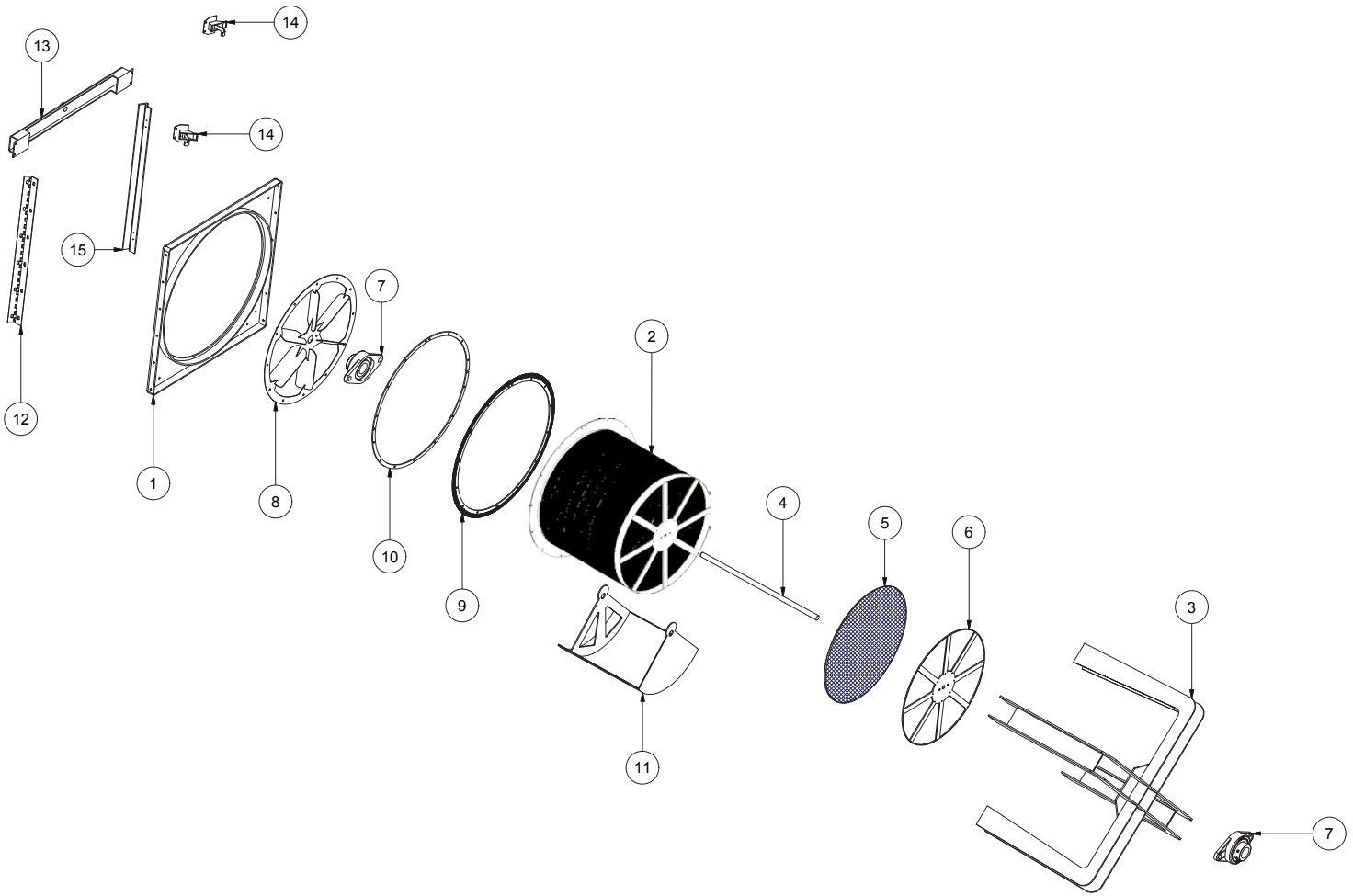

ITEM #	PART NO.	DESCRIPTION
*	RAS.100	Chaffe Assembly
1	RAS.102	Base Frame and Support Frame Assembly (#1 and #3 welded together).
2	RAS.103	Barrell Assembly
3	RAS.104	Support Frame, thru 04/02; after May 2002 must order RAS.102A
4	RAS.105	Shaft
5	RAS.106	Mesh Screen
6	RAS.107	Screen Holder
7	RAS.108	Flange Bearing

ITEM #	PART NO.	DESCRIPTION
8	RAS.101	Fan
9	RAS.109	Strip Brush
10	RAS.110	Brush Holder
11	RAS.111	Air Deflector
12	RAS.112	Hinge
13	RAS.113	Shaft Bracket
14	LCT609.602	Over center Latch, all but LCT650
	LCT650.114	Destaco Latch, not shown, LCT650 only
15	RAS.114	Angle Frame, LCT650 only



7-0

7.0 CLUTCH GROUP

7.0 CLUTCH GROUP

7-0	90
7.1 AutoHD PTO Clutch Group.....	91
7.2 AutoHD PTO Assembly Group	92
7.3 AutoHD PTO Linkage Group	93
7.4 Clutch Assist Group	94
7.5 Kraft Fluid Drive Group (Optional).....	95
7.6 Kraft Fluid Drive Installation (Optional).....	96
7.7 Kraft Fluid Drive Breakdown (Optional)	97
7.8 Kraft Fluid Drive Common Parts (Optional).....	98

CLUTCH GROUP

ODB COMPANY
5118 Glen Alden Drive
Richmond, VA 23231
800-446-9823

7.1 AutoHD PTO Clutch Group

February 2006 - Present

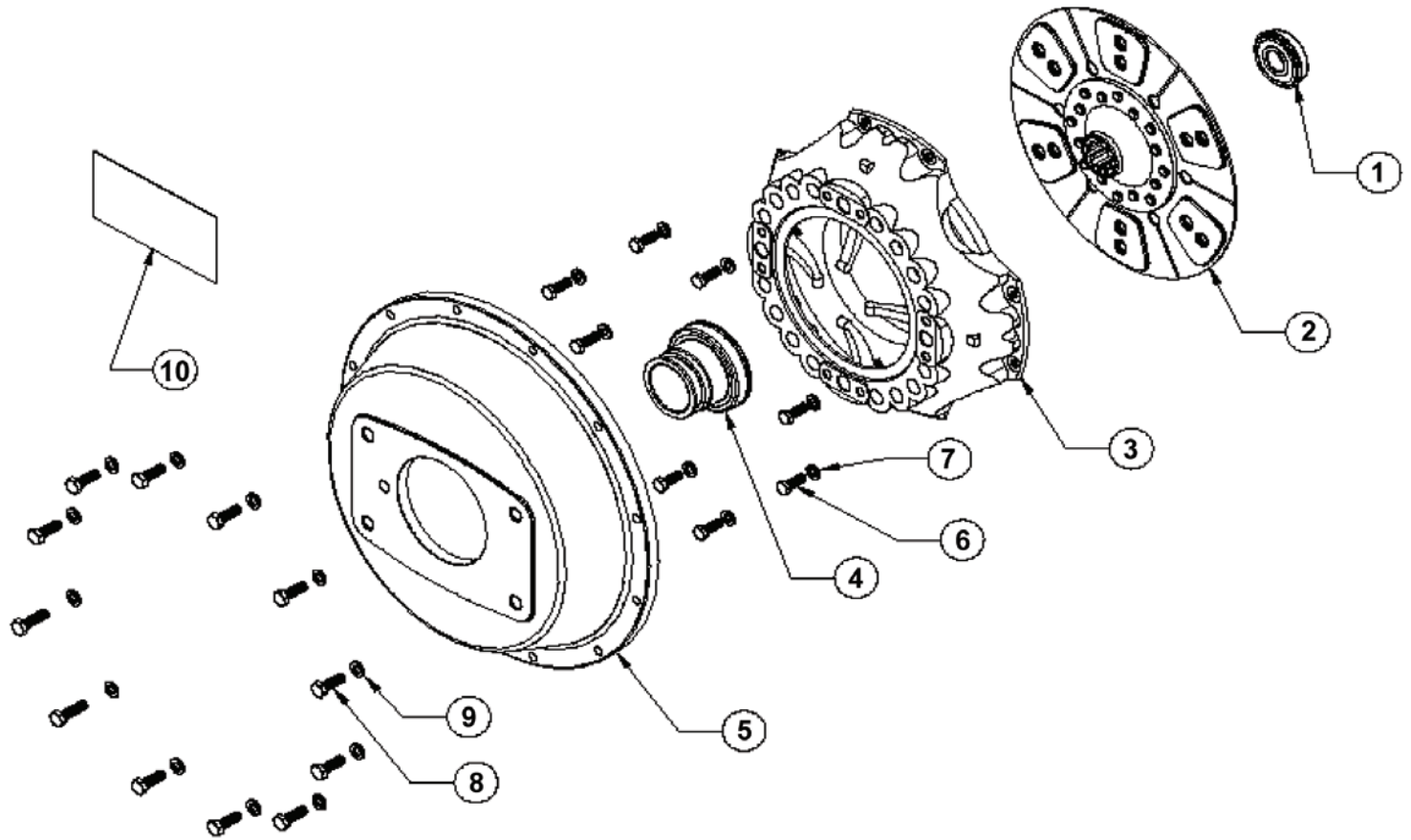

ITEM #	PART NUMBER	DESCRIPTION
*	OD-48080050.8OF	*Complete PTO and Clutch Assembly 03/08 -
1	OD-41500217	Pilot Bearing, JD
2	OD-41500237	Clutch Disk
3	OD-LC1919	Pressure Plate, 03/08 -
4	OD-41500248	Throw out Bearing, 03/08 -
5	OD-41500172	Clutch Cover
6	OD-45000054	Bolt, 3/18-16 x 1"
7	OD-45000063	Lock Washer, 3/8"
8	OD-45000226	Bolt, M10-1.50 x 35MM
9	OD-45000046	Lock Washer, M10
10	OD-41500216	Decal, Diesel Clutch

7.2 AutoHD PTO Assembly Group

March 2008 - Present

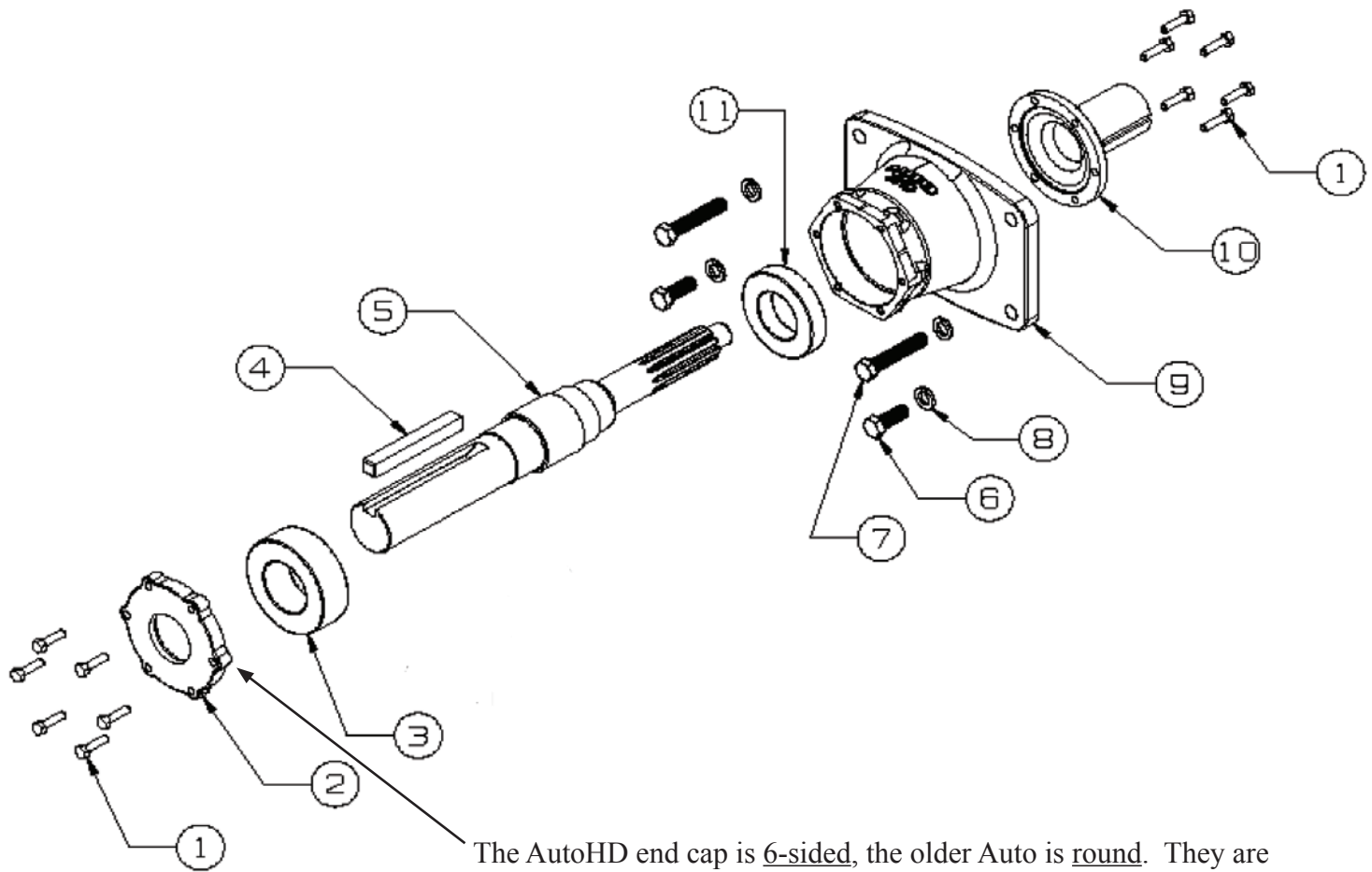

The AutoHD end cap is 6-sided, the older Auto is round. They are not interchangeable! Some units in the time period above used the standard Auto PTO. Please verify.

ITEM #	PART NUMBER	DESCRIPTION
*	OD-41500252	Complete PTO Assembly (items 1 -11,13)
**	OD-48080050.8OF	**Complete PTO & Clutch Assembly
1	OD-45000212	Bolt, 5/16-18 x 1-1/4" HD model
2	OD-41500205M	Bearing Retainer Cover
3	OD-41500206	PTO Bearing, Rear
4	OD-LCT650.601K OD-LCT650.601F	Key, Stepdown--direct drive units only Key, belt drive units only
5	OD-41500203	PTO shaft
6	OD-45000105	Bolt, 9/16-12 x 1- 3/4"
7	OD-45000177	Bolt, 9/16-12 x 3"
8	OD-45000103	Lock Washer, 9/16"
9	OD-41500204	PTO Housing
10	OD-41500242	PTO Collar, 03/08 - present
11	OD-41500207	PTO Bearing, Front

7.3 AutoHD PTO Linkage Group

March 2008 - Present

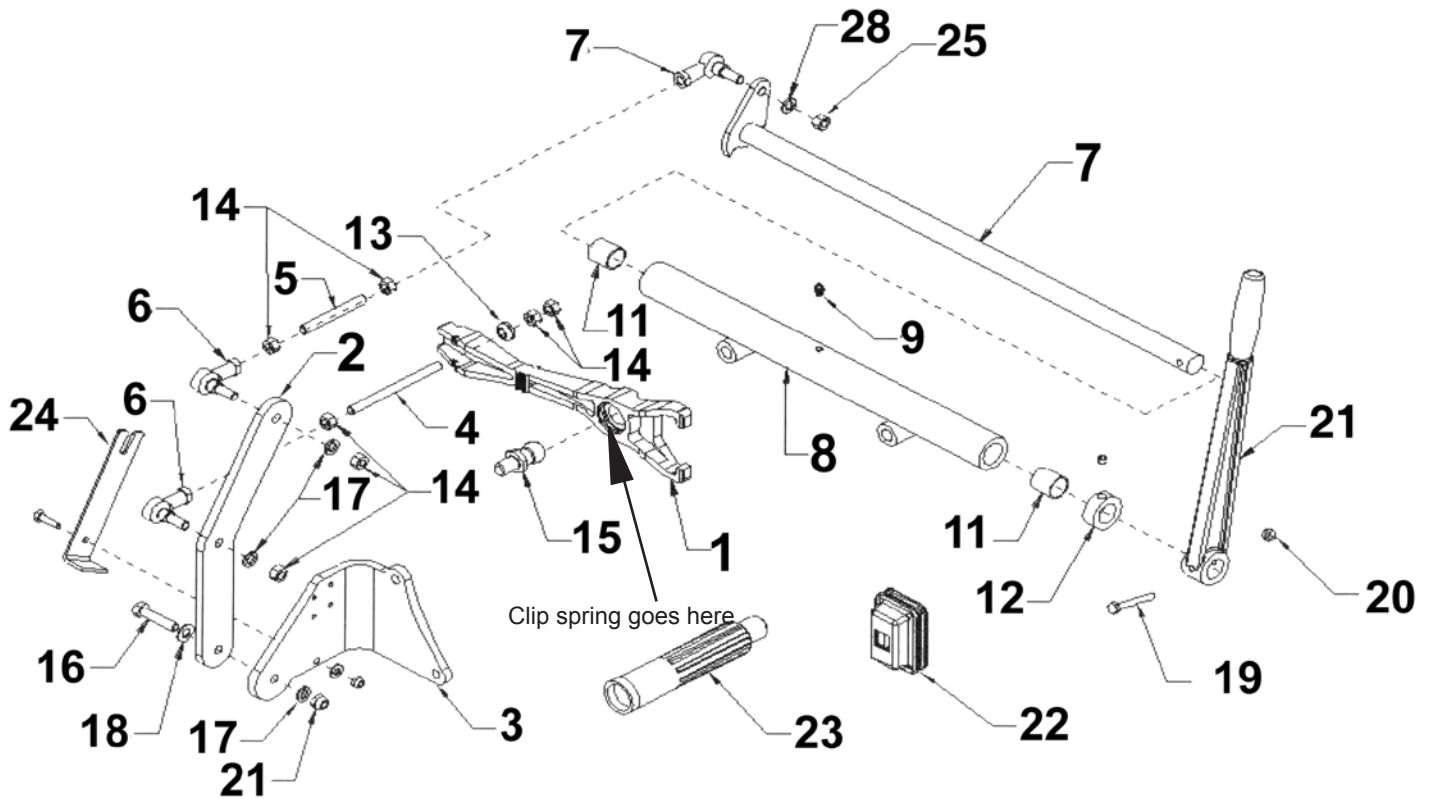

ITEM #	PART NO.	DESCRIPTION
1	41500251	Fork, 03/08-
NS	41500174	Clip Spring in Fork
NS	41500999	Return Spring
2	41500095	Linkage Bracket
3	41500241	Linkage Bracket
4	41500065	Linkage Rod
5	41500066	Linkage Rod
6	41500019	Linkage Rod End
7	see below	Shaft, Lever
8	41500102	Shaft Housing, AutoHD
9	41500043	Grease Zerk
10	NLA	NLA

ITEM #	PART NO.	DESCRIPTION
11	41500045	Shaft Bushing
12	41500046	Shaft Collar
13	41500030	Rocker Ball
14	45000050	Nut, 3/8 - 16
15	41500072	Pivot Ball 03/08-
16	45000177	Bolt, 3/8 - 16 x 1 3/4"
17	45000063	Lock Washer, 3/8"
18	45000064	Flat Washer, 3/8"
19	45000012	Bolt, 1/4 - 28 x 2"
20	45000015	Locknut, 1/4 - 28
21	41500044	Handle
22	41500175	Boot
23	41500164	Alignment Tool
24	41500103	Alignment Tool

7.4 Clutch Assist Group

Auto PTO- John Deere 4045D/T (11/00 -)

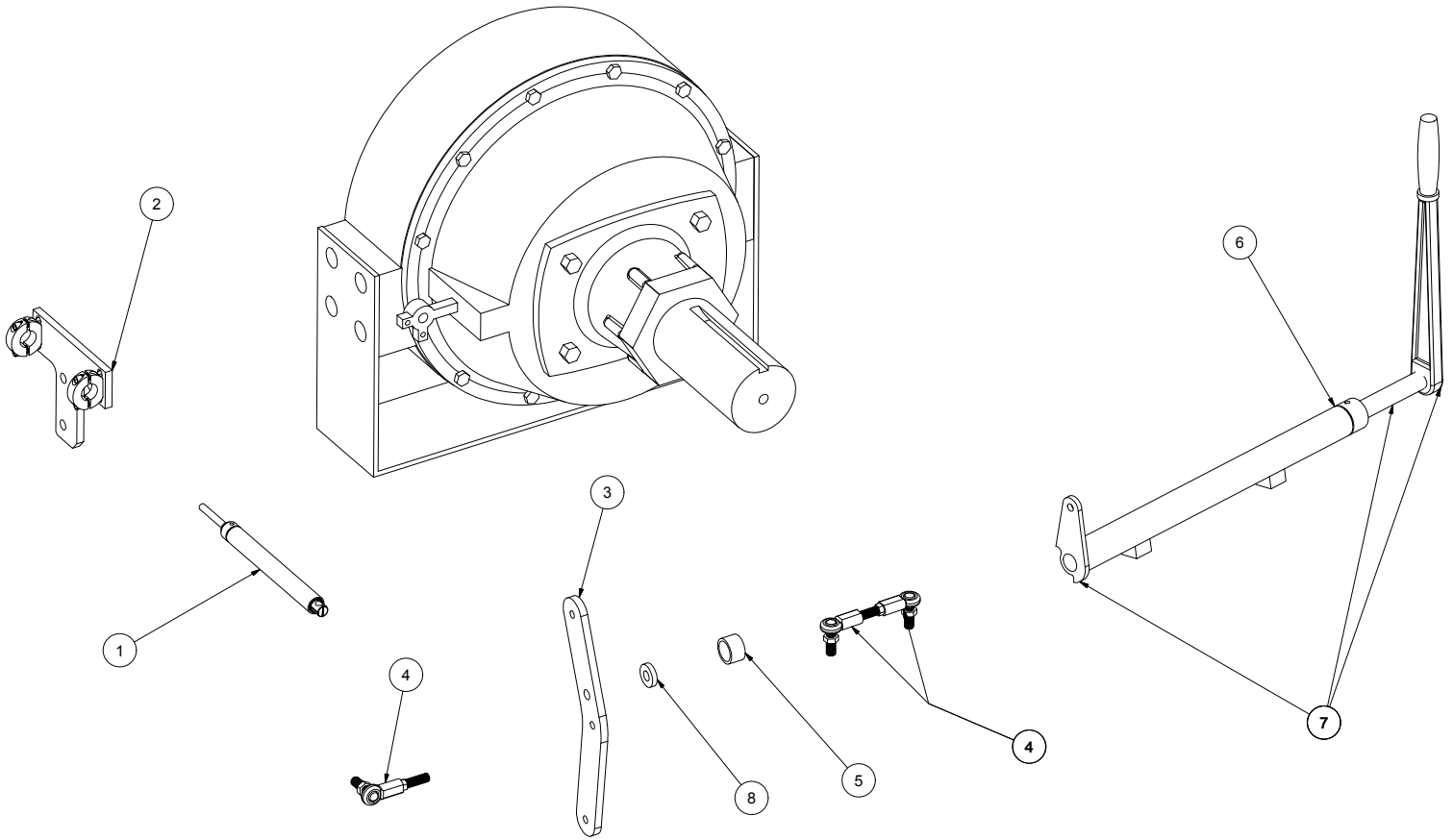

ITEM #	PART NUMBER	DESCRIPTION
1	400050.A	Clutch Cylinder
2	400054.C	Cylinder Support Bracket, JD
3	41500095	Clutch Bracket Arm, Auto HD
4	41500019	Linkage, Rod end
	41500019A	Linkage, Threaded insert
5	400050.C1	Bearing
6	41500102	Pivot Shaft Tube, Auto HD
7	41500041A.HD	Pivot Shaft,
8	400050.C2	Spacer

7.5 Kraft Fluid Drive Group (Optional)

Fluid Drive Coupler (Optional)

TRANSFLUID

trasmissioni industriali



1000B Northbrook Parkway

Suwanee, GA 30024

Ph: 770-963-6288

Fax: 770-963-9678

E-mail: transfluid@kraftpower.com

Massachusetts - New Jersey - New York - North
Carolina - Ohio - Pennsylvania

INSTALLATION AND MAINTENANCE MANUAL

THIS MANUAL CONTAINS INSTRUCTIONS FOR
INSTALLATION, START UP, FUNCTIONING, AND
MAINTENANCE KFBD POWER TAKE OFFS.

WE SUGGEST THAT ANY PERSON WHO IS
RESPONSIBLE FOR USE AND/OR MAINTENANCE
SHOULD BE PROVIDED WITH THIS MANUAL. THE
RESPECT OF RULES, CONTAINED IN THIS MANUAL IS
MANDATORY FOR WARRENTY VALIDITY.

WE REQUIRE THAT, FOR SPARE PARTS ORDERS, IT
IS IMPORTANT TO PROVIDE, BESIDES PART NUMBER
AND QUANTITY: MODEL, SPECIFICATION No AND
SERIAL No WHICH ARE STAMPED ON NAME PLATE.

Type :

Spec. nr. :

Serial nr. :

13KFBD

drive with us

7.6 Kraft Fluid Drive Installation (Optional)

Fluid Drive Coupler (Optional)

 <p>trasmissioni industriali</p>	 <p>13 KFBD MANUALE INSTALLAZIONE, USO E MANUTENZIONE INSTALLATION, USE AND MAINTENANCE MANUAL</p>	<p>TF 6217 Rev.0 1/3</p>				
<p>Questo manuale contiene le istruzioni per l'installazione, l'avviamento, l'uso e la manutenzione del giunto idrodinamico tipo KFBD. CONSIGLIAMO CHE I RESPONSABILI DELL'USO E DELLA MANUTENZIONE DEL KFBD, VENGANO DOTATI DEL PRESENTE MANUALE. IL NON RISPETTO DELLE REGOLE CITATE IN QUESTO MANUALE, PROVOCA IL DECADERE DELLA GARANZIA.</p> <p>Ricordiamo che, per ordinare le parti di ricambio, e' importante specificare, oltre al numero di dettaglio e quantita' richiesta, anche: TIPO - N° di SPECIFICA - N° di SERIE del KFBD, che si trovano stampigliati sulla targhetta di identificazione a bordo macchina.</p> <p><i>This manual contains instructions for installation, start up, working, and maintenance of KFBD fluid coupling.</i></p> <p>WE SUGGEST THAT ANY PERSON WHO IS RESPONSIBLE FOR USE AND/OR MAINTENANCE, SHOULD BE PROVIDED WITH THIS MANUAL. THE RESPECT OF RULES, CONTAINED IN THIS MANUAL, IS MANDATORY FOR WARRANTY VALIDITY.</p> <p><i>We recall that, for spare parts order, it is important to provide, besides detail number and quantity, even: TYPE - SPECIFICATION Nr. - SERIAL Nr. of KFBD that are stamped on identification metal plate.</i></p>						
<table border="1"> <thead> <tr> <th data-bbox="289 590 824 615">DESCRIZIONE</th> <th data-bbox="824 590 1367 615">DESCRIPTION</th> </tr> </thead> <tbody> <tr> <td data-bbox="289 615 824 758"> Il KFBD e' un giunto idrodinamico la cui parte esterna, motrice, e' collegata al volano di un motore endotermico mediante un giunto elastico ed il cui albero di uscita e' supportato da un cuscinetto orientabile a rulli, lubrificato ad olio, alloggiati in una campana di supporto flangiata al coprivolano del motore. Un secondo cuscinetto, alloggiato nel volano, sostiene l'albero di uscita dal lato motore. Il KFBD e' adatto per applicazioni con puleggia od i linea. </td> <td data-bbox="824 615 1367 758"> KFBD is a fluid coupling having the outer driving impeller connected to the internal combustion engine flywheel through an elastic coupling. The output shaft is supported by a spherical roller bearing, oil lubricated, fitted in a cover flanged to the engine flywheel housing. Another bearing, fitted into the flywheel, supports the output shaft at the engine side. The KFBD is suitable for pulley or in line applications. </td> </tr> </tbody> </table>			DESCRIZIONE	DESCRIPTION	Il KFBD e' un giunto idrodinamico la cui parte esterna, motrice, e' collegata al volano di un motore endotermico mediante un giunto elastico ed il cui albero di uscita e' supportato da un cuscinetto orientabile a rulli, lubrificato ad olio, alloggiati in una campana di supporto flangiata al coprivolano del motore. Un secondo cuscinetto, alloggiato nel volano, sostiene l'albero di uscita dal lato motore. Il KFBD e' adatto per applicazioni con puleggia od i linea.	KFBD is a fluid coupling having the outer driving impeller connected to the internal combustion engine flywheel through an elastic coupling. The output shaft is supported by a spherical roller bearing, oil lubricated, fitted in a cover flanged to the engine flywheel housing. Another bearing, fitted into the flywheel, supports the output shaft at the engine side. The KFBD is suitable for pulley or in line applications.
DESCRIZIONE	DESCRIPTION					
Il KFBD e' un giunto idrodinamico la cui parte esterna, motrice, e' collegata al volano di un motore endotermico mediante un giunto elastico ed il cui albero di uscita e' supportato da un cuscinetto orientabile a rulli, lubrificato ad olio, alloggiati in una campana di supporto flangiata al coprivolano del motore. Un secondo cuscinetto, alloggiato nel volano, sostiene l'albero di uscita dal lato motore. Il KFBD e' adatto per applicazioni con puleggia od i linea.	KFBD is a fluid coupling having the outer driving impeller connected to the internal combustion engine flywheel through an elastic coupling. The output shaft is supported by a spherical roller bearing, oil lubricated, fitted in a cover flanged to the engine flywheel housing. Another bearing, fitted into the flywheel, supports the output shaft at the engine side. The KFBD is suitable for pulley or in line applications.					
<p>Prima di iniziare il montaggio del KFBD sul motore, e' bene verificare che il volano rientri nelle tolleranze SAE. Questo e' importante soprattutto per il buon funzionamento del giunto elastico. (Vedere foglio 2/3 Fig.1)</p> <p><i>Before KFBD be mounted onto the engine, it is recommended to check that flywheel be within SAE tolerances. This is very important for elastic coupling good working. (see sheet 2/3 Fig.1)</i></p>						
<table border="1"> <thead> <tr> <th data-bbox="289 953 824 978">INSTALLAZIONE (vedere foglio 2/3)</th> <th data-bbox="824 953 1367 978">INSTALLATION (see sheet 2/3)</th> </tr> </thead> <tbody> <tr> <td data-bbox="289 978 824 1751"> <ol style="list-style-type: none"> Montare l'anello di trascinamento del giunto elastico sul volano del motore. Montare il cuscinetto pilota, ingrassato a vita, sull'albero del KFBD. Montare la flangia SAE 3 sul coprivolano. Posizionare il gruppo completo, osservando con cura l'allineamento dell'albero nel cuscinetto pilota e dei blocchetti del giunto elastico con l'anello di trascinamento montato sul volano. La campana esterna deve essere orientata in modo da avere l'apertura per il riempimento dell'olio a circa 60° dalla verticale, in senso orario guardando il volano del motore. Così montato, si avra' l'apertura di drenaggio dell'olio in basso. Infine fissare il gruppo con le apposite viti sulla flangia esterna. Riempimento olio giunto (vedere tabella olii consigliati). Togliere il coperchio che protegge il tappo di carico. Ruotare il giunto sino a portare il tappo in corrispondenza del segno di riferimento X sulla verticale (X-1-2-3-4 dipende dall'applicazione). Togliere il tappo e riempire fino allo sbocco dal foro (13KFBD X=5,2 lt.), quindi chiudere utilizzando del sigillante sul filetto. La coppia di serraggio e' 30 Nm per tappo 3/8". Rimontare il coperchio di protezione. Riempimento grasso (vedere tabella grassi consigliati). Mediante l'apposito ingrassatore,, riempire la camera di lavoro del cuscinetto fino a far fuoriuscire il grasso attorno all'albero Dare alcuni colpi, con un martello non metallico, sull'estremita' dell'albero onde eliminare ogni eventuale tensione sui cuscinetti dovuta alla resistenza offerta dal cuscinetto pilota, quando esso viene montato forzato nella sede del volano. Al primo avviamento, far girare il gruppo innestato, per almeno 10 minuti, con il motore alla meta' dei giri massimi. </td> <td data-bbox="824 978 1367 1751"> <ol style="list-style-type: none"> Mount elastic coupling driving ring, onto engine flywheel. Mount pilot bearing, greased for life, onto KFBD shaft. Mount SAE 3 flange onto flywheel housing. Install complete group paying attention at alignment between shaft and pilot bearing as well as alignment between rubber blocks and driving ring. External housing must be orientated to get the oil fill opening at about 60° clockwise from vertical line, looking at the flywheel. In such a way, the oil drain opening will be downwards. Therefore tighten screws of external flange. Fluid coupling oil filling (see recommended oil table). Remove cover. Turn fluid coupling until X mark be on vertical line (X-1-2-3-4 depends on application). Remove plug and fill until oil overflows (13KFBD fill X=5,2 lt.). Therefore fit the plug using sealant on thread. Tightening torque is 30 Nm for 3/8" plug. Fit again the cover. Grease filling (see recommended grease table). Through the grease filler, fill grease until it comes out around the shaft. Rap the shaft on the end to relieve any preloading that may result due to the resistance of pilot bearing when being pressed into the flywheel. At first start up, run the unit engaged and engine at half of max speed for not less than 10 minutes. </td> </tr> </tbody> </table>			INSTALLAZIONE (vedere foglio 2/3)	INSTALLATION (see sheet 2/3)	<ol style="list-style-type: none"> Montare l'anello di trascinamento del giunto elastico sul volano del motore. Montare il cuscinetto pilota, ingrassato a vita, sull'albero del KFBD. Montare la flangia SAE 3 sul coprivolano. Posizionare il gruppo completo, osservando con cura l'allineamento dell'albero nel cuscinetto pilota e dei blocchetti del giunto elastico con l'anello di trascinamento montato sul volano. La campana esterna deve essere orientata in modo da avere l'apertura per il riempimento dell'olio a circa 60° dalla verticale, in senso orario guardando il volano del motore. Così montato, si avra' l'apertura di drenaggio dell'olio in basso. Infine fissare il gruppo con le apposite viti sulla flangia esterna. Riempimento olio giunto (vedere tabella olii consigliati). Togliere il coperchio che protegge il tappo di carico. Ruotare il giunto sino a portare il tappo in corrispondenza del segno di riferimento X sulla verticale (X-1-2-3-4 dipende dall'applicazione). Togliere il tappo e riempire fino allo sbocco dal foro (13KFBD X=5,2 lt.), quindi chiudere utilizzando del sigillante sul filetto. La coppia di serraggio e' 30 Nm per tappo 3/8". Rimontare il coperchio di protezione. Riempimento grasso (vedere tabella grassi consigliati). Mediante l'apposito ingrassatore,, riempire la camera di lavoro del cuscinetto fino a far fuoriuscire il grasso attorno all'albero Dare alcuni colpi, con un martello non metallico, sull'estremita' dell'albero onde eliminare ogni eventuale tensione sui cuscinetti dovuta alla resistenza offerta dal cuscinetto pilota, quando esso viene montato forzato nella sede del volano. Al primo avviamento, far girare il gruppo innestato, per almeno 10 minuti, con il motore alla meta' dei giri massimi. 	<ol style="list-style-type: none"> Mount elastic coupling driving ring, onto engine flywheel. Mount pilot bearing, greased for life, onto KFBD shaft. Mount SAE 3 flange onto flywheel housing. Install complete group paying attention at alignment between shaft and pilot bearing as well as alignment between rubber blocks and driving ring. External housing must be orientated to get the oil fill opening at about 60° clockwise from vertical line, looking at the flywheel. In such a way, the oil drain opening will be downwards. Therefore tighten screws of external flange. Fluid coupling oil filling (see recommended oil table). Remove cover. Turn fluid coupling until X mark be on vertical line (X-1-2-3-4 depends on application). Remove plug and fill until oil overflows (13KFBD fill X=5,2 lt.). Therefore fit the plug using sealant on thread. Tightening torque is 30 Nm for 3/8" plug. Fit again the cover. Grease filling (see recommended grease table). Through the grease filler, fill grease until it comes out around the shaft. Rap the shaft on the end to relieve any preloading that may result due to the resistance of pilot bearing when being pressed into the flywheel. At first start up, run the unit engaged and engine at half of max speed for not less than 10 minutes.
INSTALLAZIONE (vedere foglio 2/3)	INSTALLATION (see sheet 2/3)					
<ol style="list-style-type: none"> Montare l'anello di trascinamento del giunto elastico sul volano del motore. Montare il cuscinetto pilota, ingrassato a vita, sull'albero del KFBD. Montare la flangia SAE 3 sul coprivolano. Posizionare il gruppo completo, osservando con cura l'allineamento dell'albero nel cuscinetto pilota e dei blocchetti del giunto elastico con l'anello di trascinamento montato sul volano. La campana esterna deve essere orientata in modo da avere l'apertura per il riempimento dell'olio a circa 60° dalla verticale, in senso orario guardando il volano del motore. Così montato, si avra' l'apertura di drenaggio dell'olio in basso. Infine fissare il gruppo con le apposite viti sulla flangia esterna. Riempimento olio giunto (vedere tabella olii consigliati). Togliere il coperchio che protegge il tappo di carico. Ruotare il giunto sino a portare il tappo in corrispondenza del segno di riferimento X sulla verticale (X-1-2-3-4 dipende dall'applicazione). Togliere il tappo e riempire fino allo sbocco dal foro (13KFBD X=5,2 lt.), quindi chiudere utilizzando del sigillante sul filetto. La coppia di serraggio e' 30 Nm per tappo 3/8". Rimontare il coperchio di protezione. Riempimento grasso (vedere tabella grassi consigliati). Mediante l'apposito ingrassatore,, riempire la camera di lavoro del cuscinetto fino a far fuoriuscire il grasso attorno all'albero Dare alcuni colpi, con un martello non metallico, sull'estremita' dell'albero onde eliminare ogni eventuale tensione sui cuscinetti dovuta alla resistenza offerta dal cuscinetto pilota, quando esso viene montato forzato nella sede del volano. Al primo avviamento, far girare il gruppo innestato, per almeno 10 minuti, con il motore alla meta' dei giri massimi. 	<ol style="list-style-type: none"> Mount elastic coupling driving ring, onto engine flywheel. Mount pilot bearing, greased for life, onto KFBD shaft. Mount SAE 3 flange onto flywheel housing. Install complete group paying attention at alignment between shaft and pilot bearing as well as alignment between rubber blocks and driving ring. External housing must be orientated to get the oil fill opening at about 60° clockwise from vertical line, looking at the flywheel. In such a way, the oil drain opening will be downwards. Therefore tighten screws of external flange. Fluid coupling oil filling (see recommended oil table). Remove cover. Turn fluid coupling until X mark be on vertical line (X-1-2-3-4 depends on application). Remove plug and fill until oil overflows (13KFBD fill X=5,2 lt.). Therefore fit the plug using sealant on thread. Tightening torque is 30 Nm for 3/8" plug. Fit again the cover. Grease filling (see recommended grease table). Through the grease filler, fill grease until it comes out around the shaft. Rap the shaft on the end to relieve any preloading that may result due to the resistance of pilot bearing when being pressed into the flywheel. At first start up, run the unit engaged and engine at half of max speed for not less than 10 minutes. 					
#6217-1 06/04/01	TRANSFLUID S.r.l. via V.Monti 19-20016 Pero (MI) Italy tel.0039-02-339316.1 - fax.0039-02-33910699 - www.transfluid.it - e-mail:info@transfluid.it					

7.8 Kraft Fluid Drive Common Parts (Optional)

Fluid Drive Coupler (Optional)



ITEM #	PART NUMBER	DESCRIPTION
1	UU-TFP7018CC	390 Degree Fuse Plug, 5/8"
2	UU-TFP2292	Seal Kit
3	UU-8202AD	Roller Bearing
4	UU-TFP103602X	Shaft
5	UU-8002DX	Bearing, small
6	UU-8002AS	Ball Bearing
7	UU-KPC2.01.5	Fluid, 1-1/2 gallon



8-0

8.0 BLOWER HOUSING GROUP

8.0 BLOWER HOUSING GROUP

8-0	99
8.1 Blower Housing Group	100
8.2 Blower Housing Face Group - LCT600.....	101
8.3 Belt Drive Assembly	102
8.4 Pedestal Group	103
8.5 Exhaust Duct Assembly	104

BLOWER HOUSING GROUP

ODB COMPANY
5118 Glen Alden Drive
Richmond, VA 23231
800-446-9823

8.1 Blower Housing Group

After February 1999

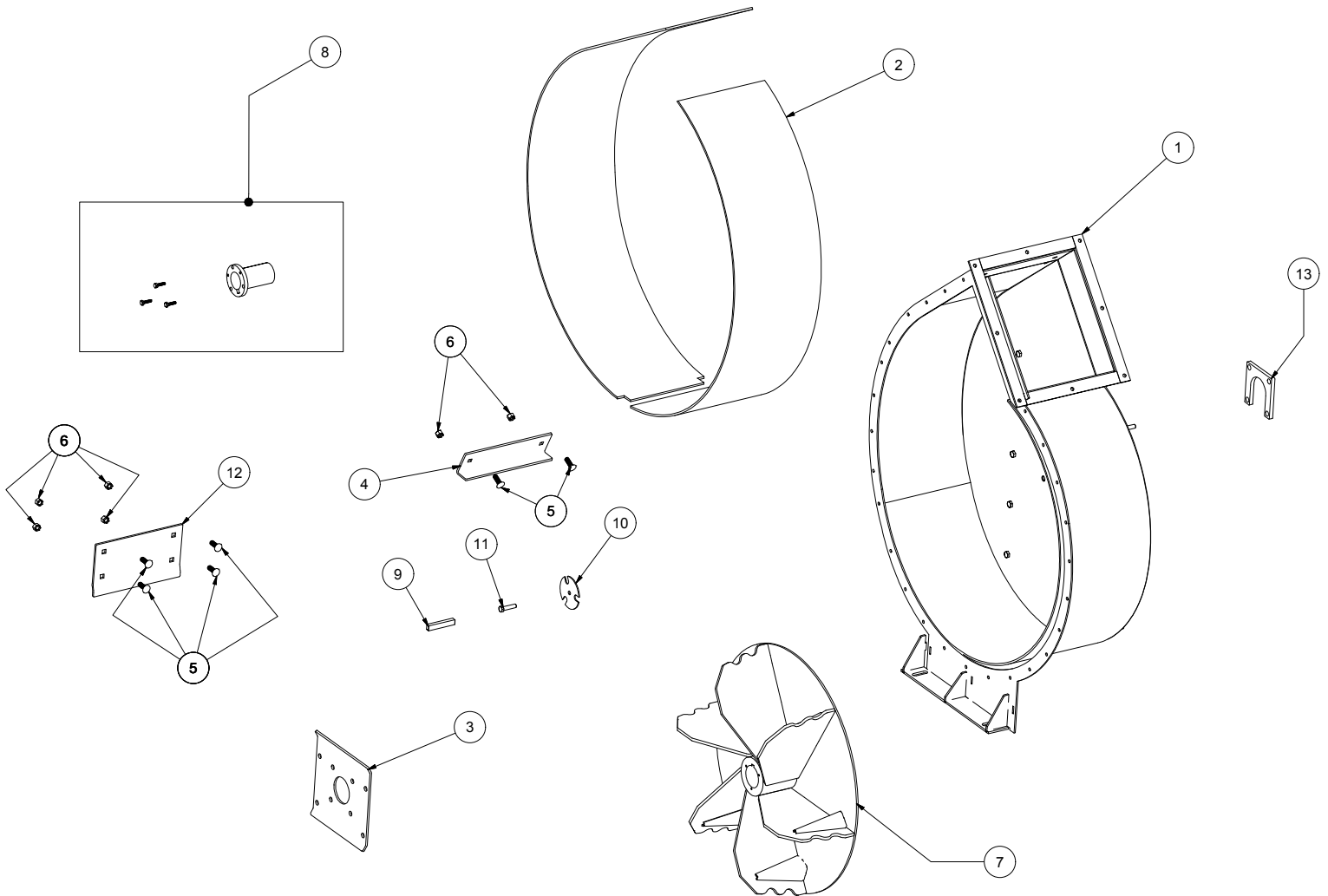

ITEM #	PART NUMBER	DESCRIPTION
1	LCT620.601	Blower Housing Back
2	LCT620.602	Liner Set
3	LCT600.603	Inner Bearing Plate
4	LCT620.602A	Bolt-In Wrap Around Liner
5	LCT620.603	Flat Head Bolt
6	LCT620.603N	Nut
7	LCT600.33	Impeller
8	LCT650.601	Impeller Bushing
9	LCT650.601F	Bushing Key
10	LCT600.615	Shaft Protector
11	5CZ.500.750	Shaft Bolt
12	LCT620.604	Liner, Straight
13	LCT650.602.D	Spacer

8.2 Blower Housing Face Group - LCT600

Single Axis Units

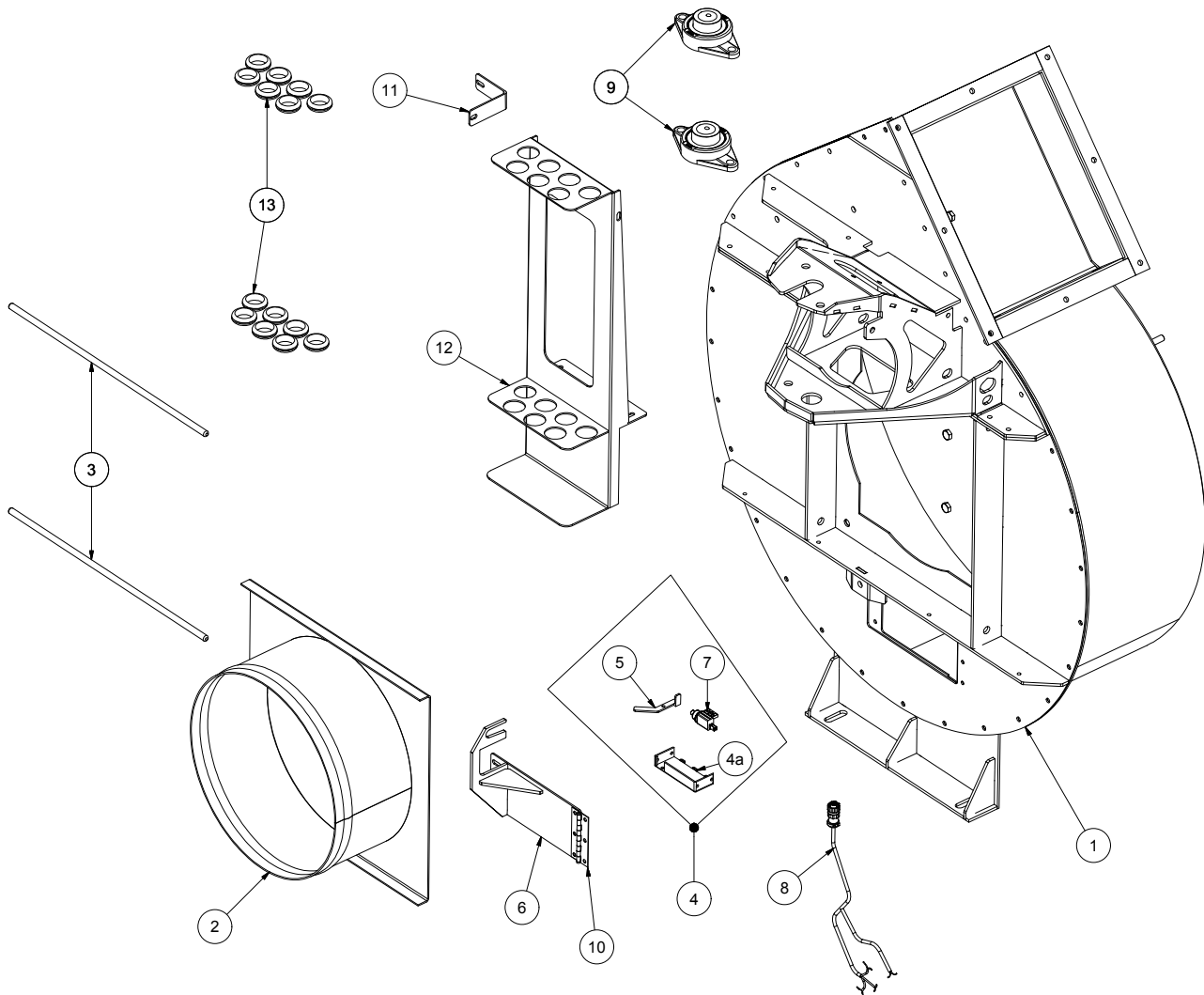

ITEM #	PART NUMBER	DESCRIPTION
1	LCT621.601FB1	Blower Housing Face
2	LCT616.604	Intake Flange
3	LCT600.635.1	Lock Rod
4	STD.4000.A	Limit Switch Box Assembly
4a	STD.4000	Limit Switch Box
5	STD.4001	Limit Switch Actuator
6	SCL621.602	Inspection Door
7	6410.51	Limit Switch
8	600.2431C	Limit Switch Harness
9	LCT616.801	Boom Bearing
10	LCT621.603	Inspection Door Hinge
11		Bracket
12	LCT600.103	Rake Rack
13	2875	Grommet

8.3 Belt Drive Assembly

After August 2012

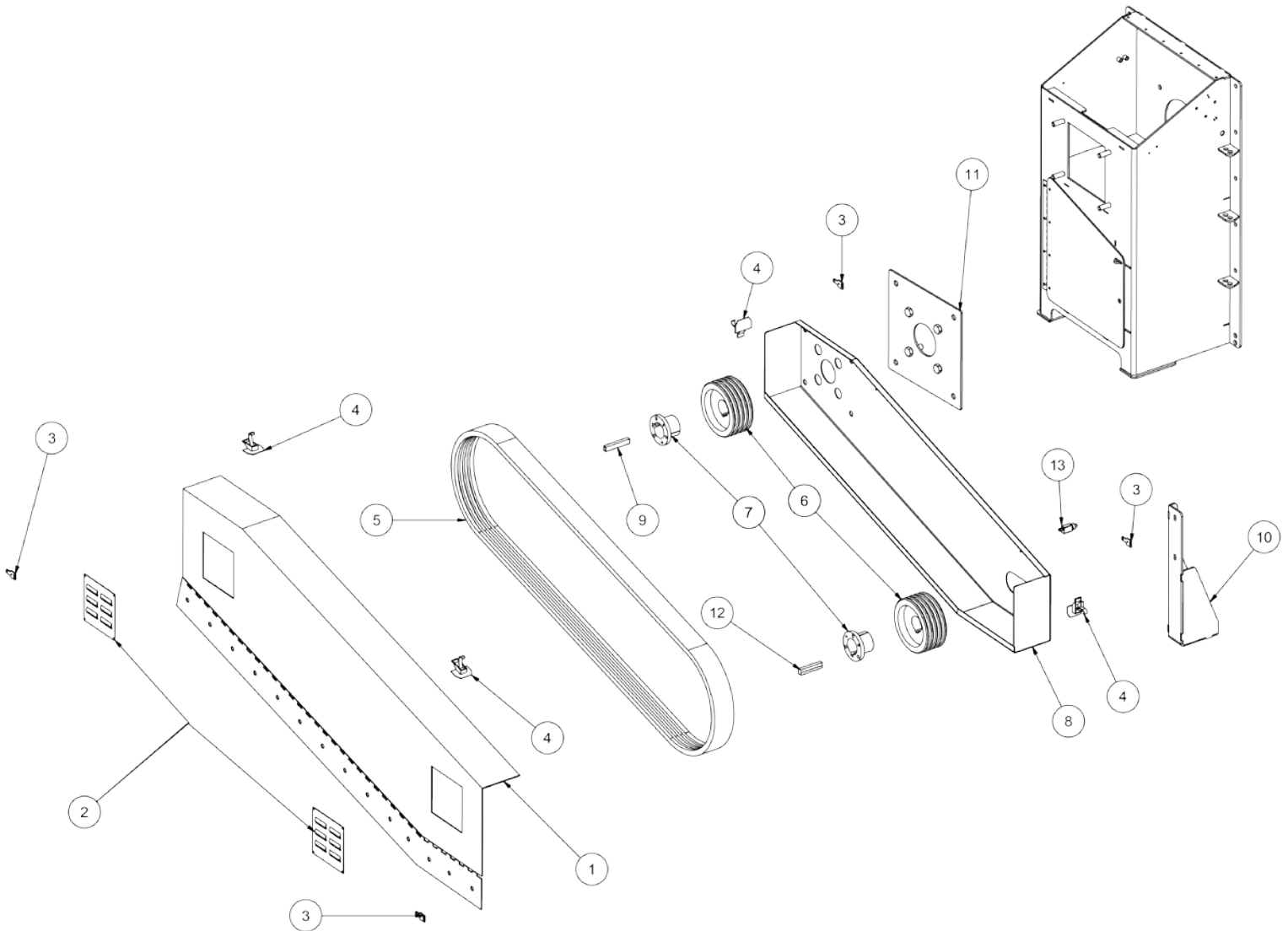

ITEM #	PART NO.	DESCRIPTION	ITEM #	PART NO.	DESCRIPTION
1	600.2250 600.2252	Belt Guard Door Hinge	8	600.2251	Belt Guard Inside Cover
2	LCT600.699	Guard Vent	9	LCT650.601F	Bushing Key
3	200042	Striker Plate	10	LCT611.622	Belt Guard Mount
4	LCT690.602	Overcenter Latch	11	LCT600.611	Outer Bearing Plate
5	LCT650.606.K	Driver Belt	12	LCT650.601K	Step Down Key,not 6000
6	LCT650.603A	Sheave (Pulley)	13	6410.51	Limit Switch
7	LCT650.604A	Bushing			

8.4 Pedestal Group

August 2012 and after

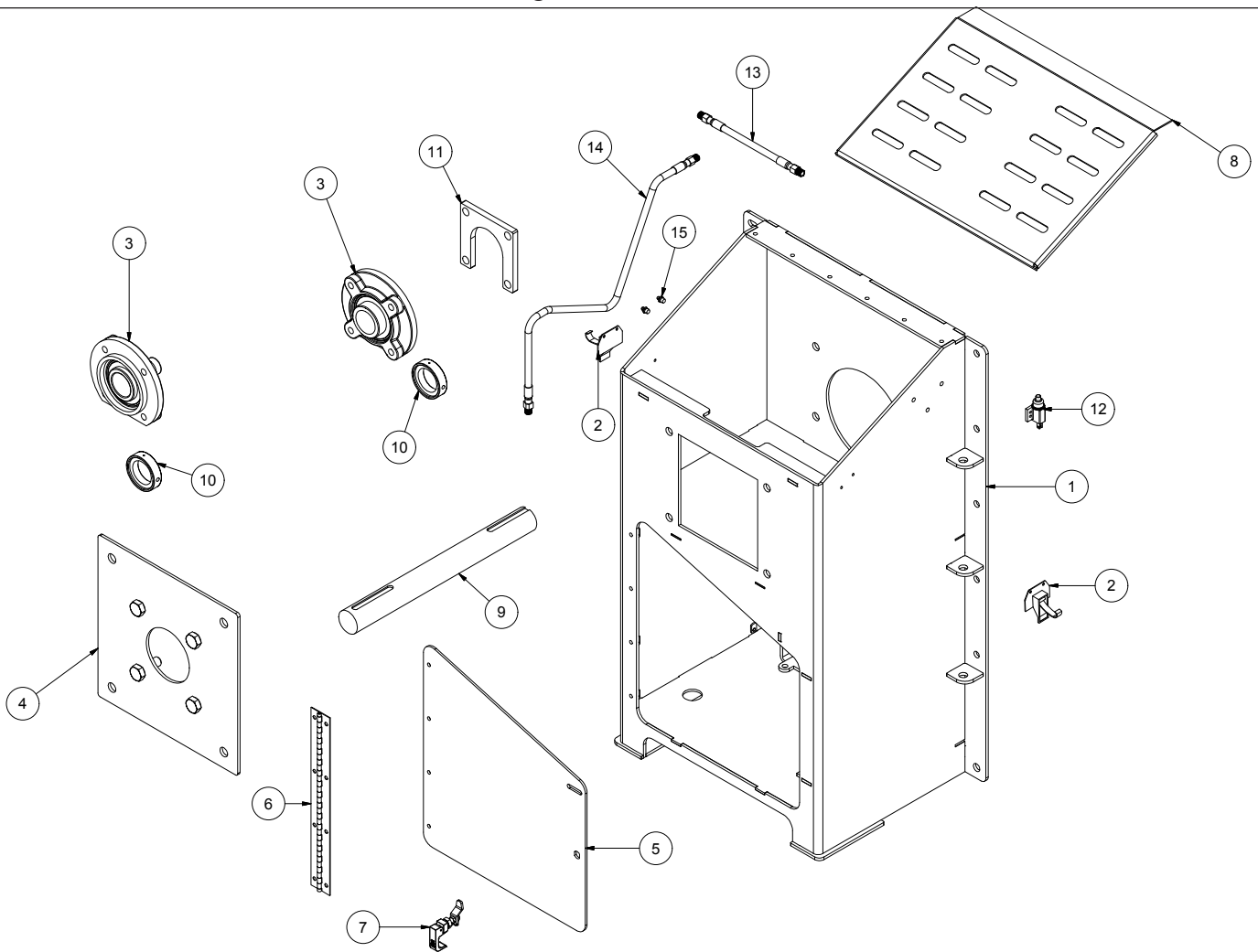

ITEM #	PART NUMBER	DESCRIPTION
1	600.2210A	Pedestal
2	LCT609.602	Overcenter Latch
3	LCT650.602.A	Flange Bearing, 2-1/4"
4	LCT600.611	Outer Bearing Plate
5	600.2213	Pedestal Utility Door
6	600.2214	Hinge
7	LCT622.602.L	Latch
8	LCT614.601	Pedstal Lid
9	LCT650.0	Shaft
10	LCT650.602.C	Lock Collar for Bearing
11	LCT650.602.D	Spacer
12	6410.51	Limit Switch
13	600.2215	Grease Hose/Line, Impellar Side Bearing, 12"
14	600.2219	Grease Hose/Line, Belt Side Bearing, 18"
15	450.1412	Grease Zerk

8.5 Exhaust Duct Assembly

LCT600 after February 2001

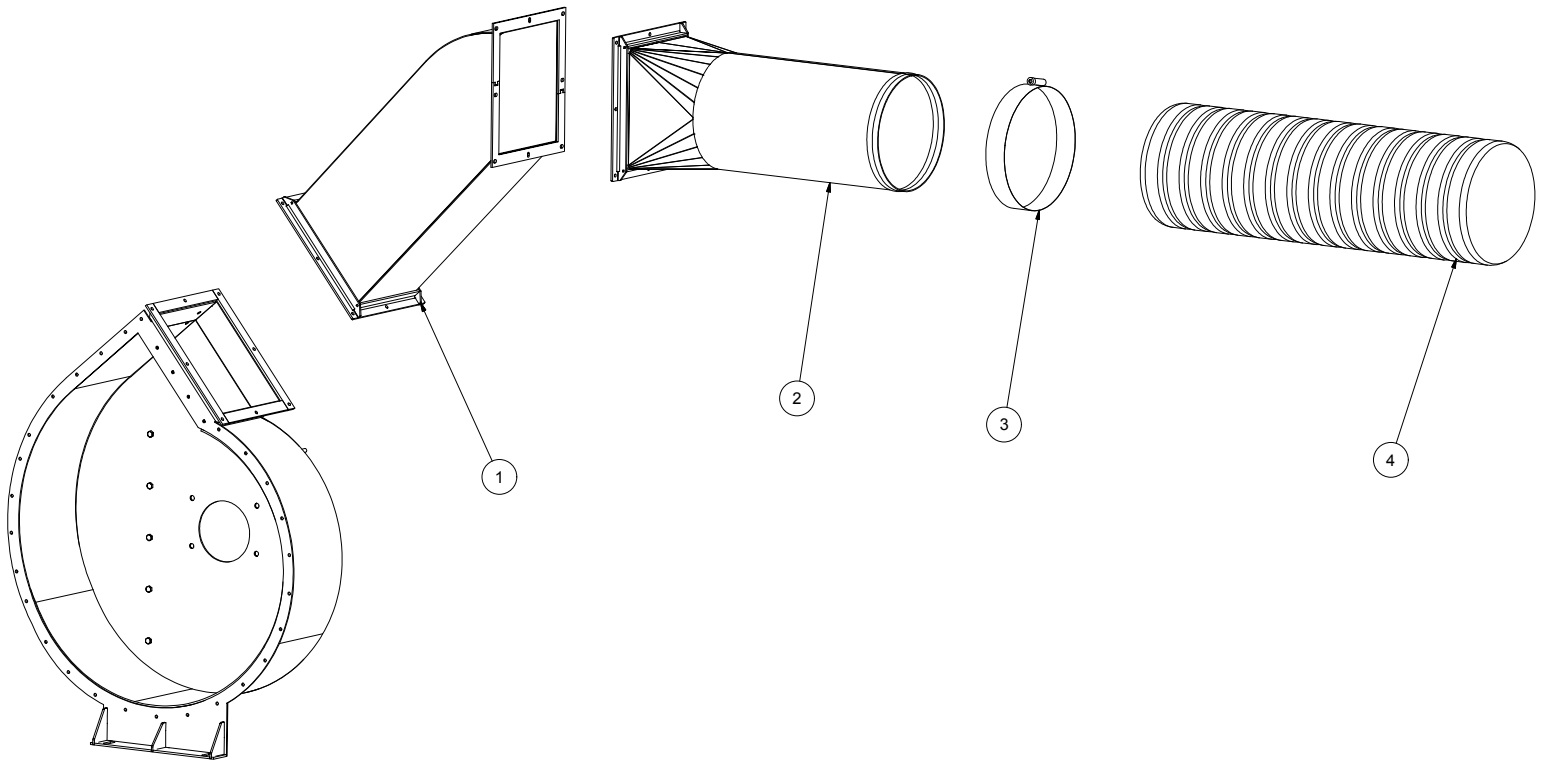

ITEM #	PART NUMBER	DESCRIPTION
1	LCT621.610	Discharge Duct
2	LCT621.611B	Transition, 61"
3	LCT616.616	Hose Band
4	LC-MDH.16.48	Exhaust Hose



9-0

9.0 TRAILER GROUP

9.0 TRAILER GROUP	
9-0	105
9.1 Trailer Bed Group	106
9.2 Fuel Tank Group	107
9.3 Tongue Group	108
9.4 Hydraulic Parking Jack - OPTIONAL.....	109
9.4 Axle Hub Assembly	110
9.5 Brake Assembly	111
9.6 Hydraulic Surge Brake Actuator - OPTIONAL.....	112

TRAILER GROUP

ODB COMPANY
5118 Glen Alden Drive
Richmond, VA 23231
800-446-9823

9.1 Trailer Bed Group

LCT600 2012 and after

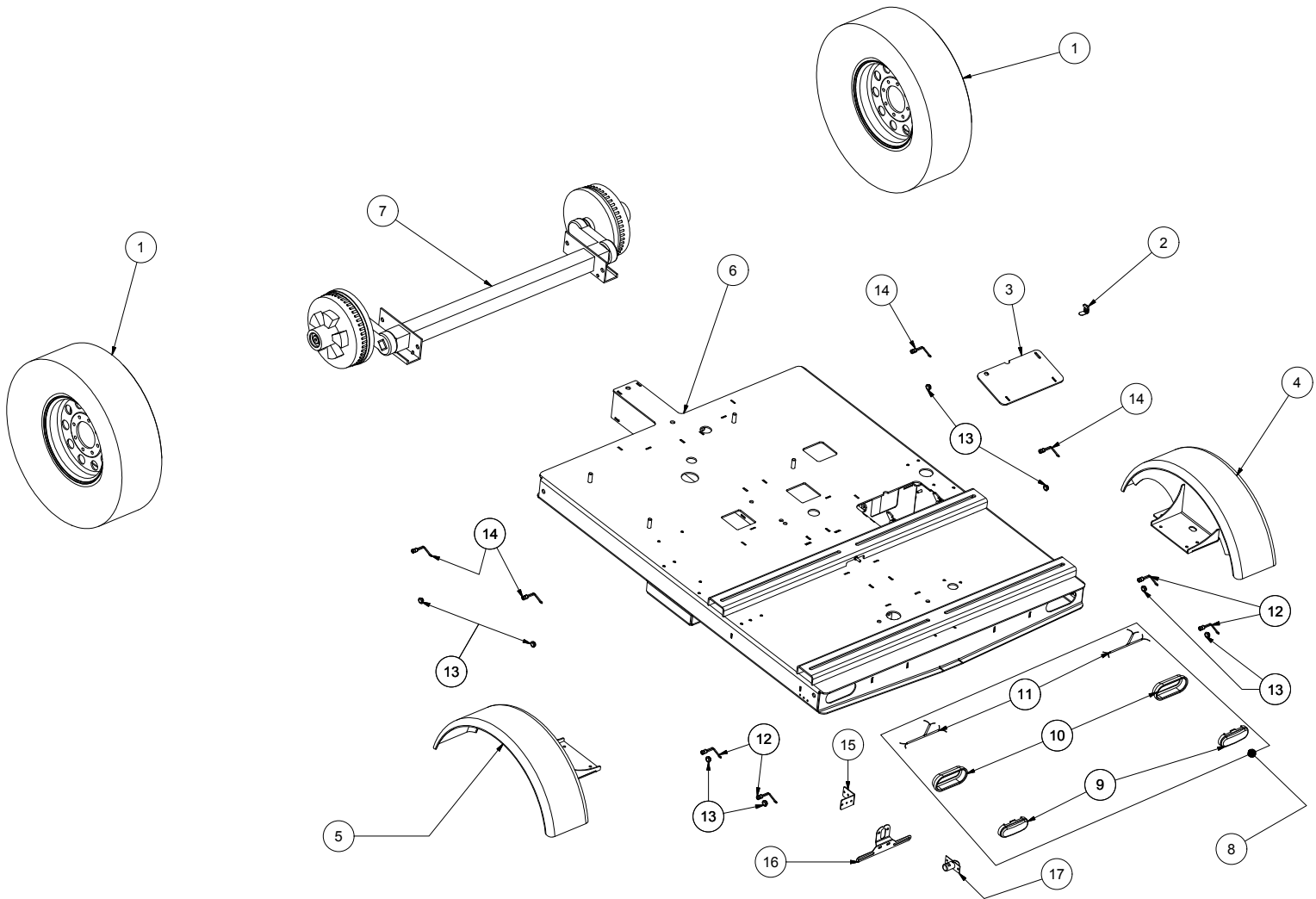

ITEM#	PART NO.	DESCRIPTION	ITEM#	PART NO.	DESCRIPTION
1	LCT622.619.08	Tire and Rim Assembly	8	STD.2414	Tail Light Assembly
	consists of:		9	OD-60250R	LED Light only
	LCT622.619T.08	Tire only	10	OD-60700	Grommet
	LCT622.619r.08	Rim only	11	OD-94706	Plug Harness
2	LCT622.602.L	Battery Box Latch	12	STD.2201	LED Market Light, Yellow
3	600.602A	Battery Box Door	13	STD.2201G	Grommet, marker light
4	LCT613.601B	Fender, RH	14	STD.2202	LED Marker Light, Red
5	LCT613.602B	Fender, LH	15	600.2437	License Plate Mount Brkt
6	LCT622.601.09	Trailer Bed, 600	16	LCT600.010	License Plate Bracket
	LCT633.630.01	Trailer Bed, 6000	17	LCT60.615B	Licesne Plate Light
7	LCT622.614TE	Axle Assembly, 600			
	6000.11	Axle Assembly, 6000			

9.2 Fuel Tank Group

April 2007 and after

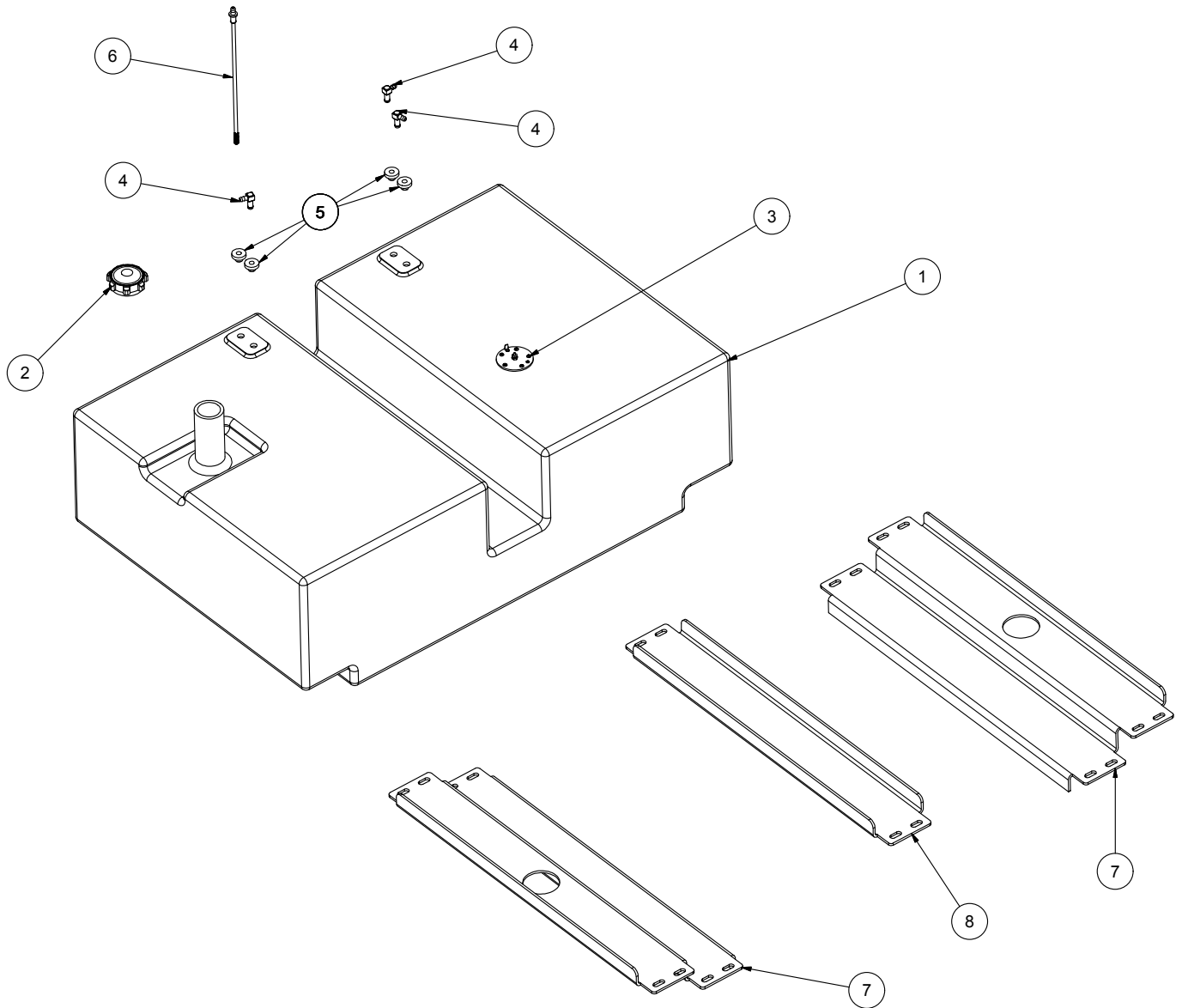

ITEM #	PART NUMBER	DESCRIPTION
1	600.2520	Fuel Tank
2	600.2521	Fuel Cap
3	9341.A.7000	Fuel Sender
4	MET633.901	Fuel Fitting (not for pickup)
5	MET633.901M	Fuel Fitting Grommet
6	600.2527	Fuel Fitting, pickup tube and screen
7	600.2523	Side Support Bracket
8	600.2522	Center Support Bracket
9	400016	Fuel Line Bracket (mounts on engine rail)

9.3 Tongue Group

LCT600

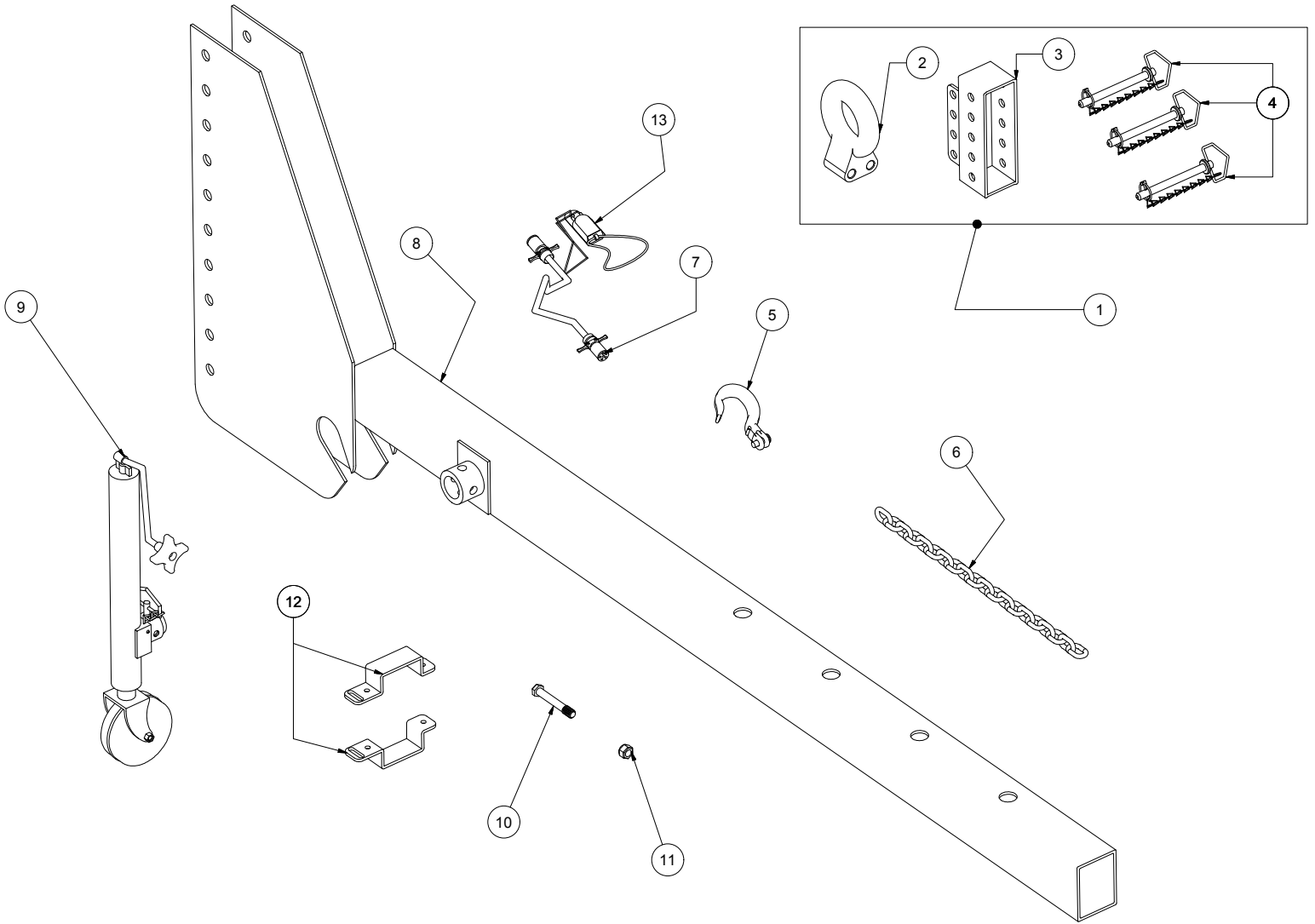

ITEM #	PART NO.	DESCRIPTION
1	LCT622.623D	Pintle Eye Assembly
	consists of	
2	LCT622.623	Pintle Eye Ring
3	LCT622.623A.2	Bracket w/ U-Channel
4	200012	Pintle Eye Pins
5	200009.1	Safety Hook, 3/8"
6	LCT600.201	Safety Chain
7	LCT622.626	Power Cord,#13 incl.

ITEM #	PART NO.	DESCRIPTION
8	LCT622.633 LCT622.634 LCT622.636	Tow Bar, LCT60C/650 Tow Bar, LCT600 Tow Bar, LCT6000
9	LCT622.624	Parking Jack
12	LCT622.635A LCT622.635B	Hose Lock Brkt,600 Hose Lock Brkt,6000
13	89102	Breakaway Switch, included in #7

9.4 Hydraulic Parking Jack - OPTIONAL

LCT60C/ 600 / 6000 / 650 - optional - Nov. 2006 and after

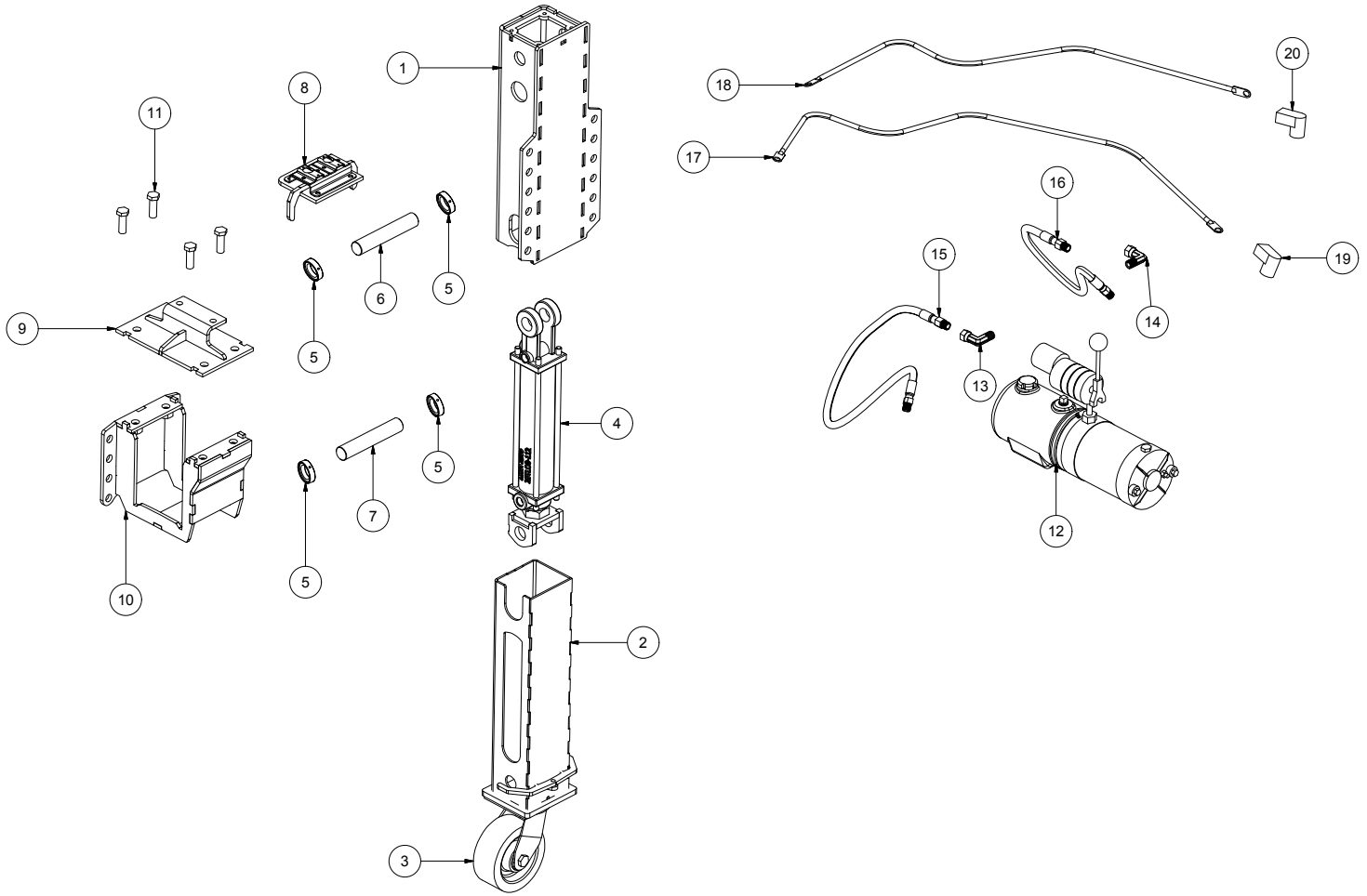

ITEM#	PART NO.	DESCRIPTION	ITEM#	PART NO.	DESCRIPTION
*	LCT622.624H1	Hyd. Parking Jack Assembly incl. all below except#1-10	11	5CZ.500.1.5	Clamp Bolts
*	LCT622.624H2	Hyd. Parking Jack Assembly complete (includes 1-19)	12	MPM310	Hydraulic Pump
1	STD.9001	Outer Tube	13	80.1552	Fitting, 90 degree
2	STD.9002	Inner Tube	14	80.1552	Fitting, 90 degree
3	STD.9003	Caster Assembly	15	STD.9009 STD.9009B	Hydraulic Hose, Top Hydraulic Hose, Top 2/3X
4	STD.9014	Cylinder	16	STD.9010 STD.9010B	Hydraulic Hose, Bottom Hydraulic Hose, Bttm 2/3x
5	STD.9006	Lock Collars	17	STD.9012	Battery Cable, Red
6	STD.9004	Top Pin	18	STD.9013	Battery Cable, Black
7	STD.9005	Bottom Pin	19	65.1306	Stud Cover, Red
8		Outer Tube Top	20	65.1307	Stud Cover, Black
9	STD.9008*	Clamp Top	Notes: *#8,9 not used on 2/3 axis units * #11-13,16-19 not used on 2/3 axis units * will work on older units(use LCT622.624H2)		
10	STD.9007 6000.9007	Clamp Bottom, 600/800/650 Clamp Bottom, 6000			

9.4 Axle Hub Assembly

LCT60C/600/650/6000

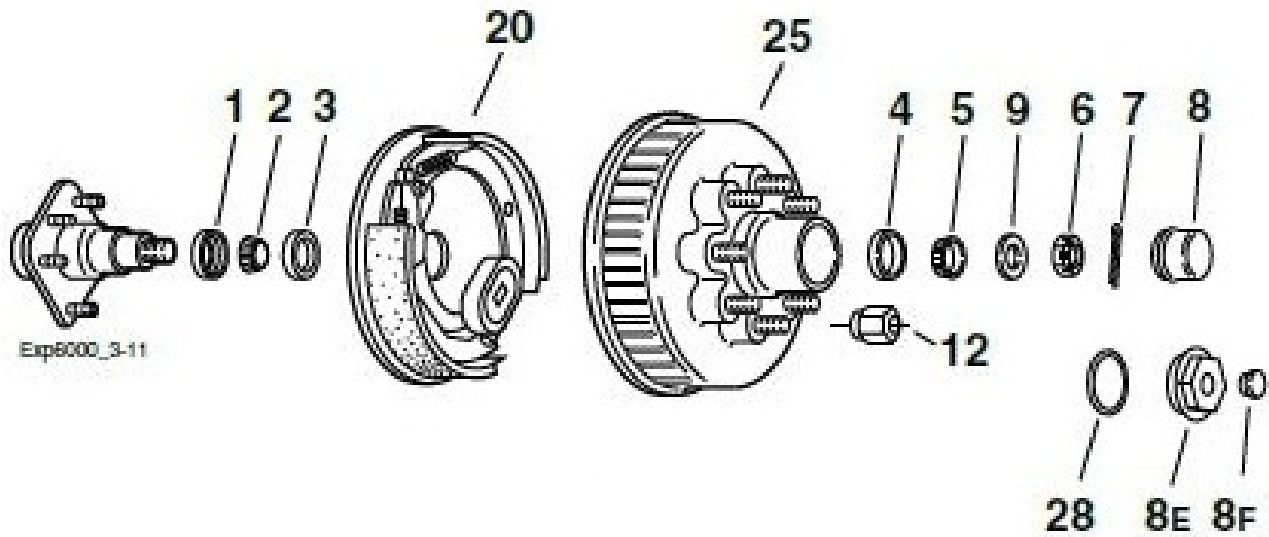

ITEM #	PART NUMBER	DESCRIPTION
1	010-036-00	Grease Seal
2	031-030-02	Inner Bearing Cone
3	031-030-01	Inner Bearing Cup
4	031-017-01	Outer Bearing Cup
5	031-017-02	Outer Cone
6	006-176-00	Spindle Nut
7	019-002-00	Cotter Pin
8	021-039-00	Cap
8E	021-042-01	Cap
8F	085-001-00	Rubber Plug
9	005-023-00	Spindle Washer
12	006.080.00	Lug Nut, 1/2-20
20	K23-180-00 K23-181-00	7K Electric Brake Assembly, LH 7K Electric Brake Assembly, RH
25	008-219-04 008-219-13 008-219-18	Grease Hub and Drum 1/2" Stud 9/16" Stud 5/8" Stud
28	010-045-00	O Ring

9.5 Brake Assembly

LCT60C/600/650/6000

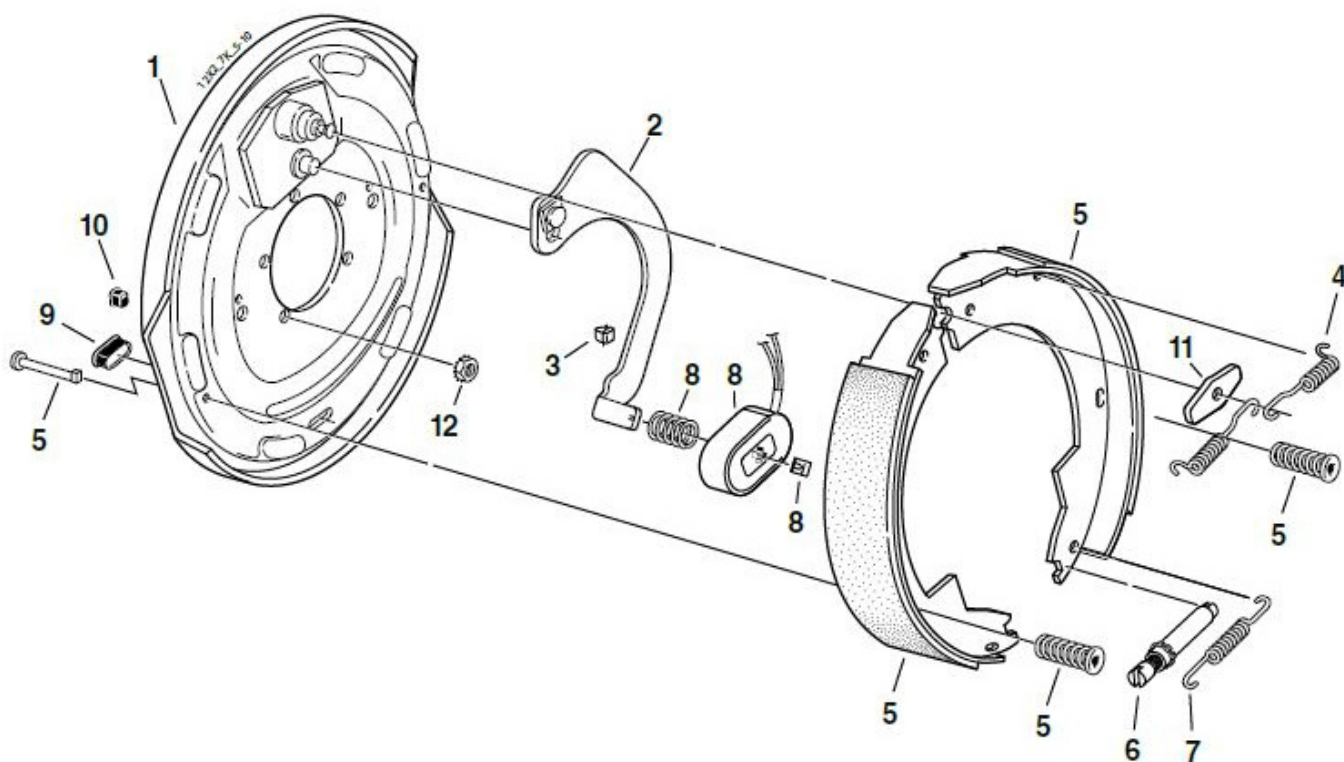

ITEM #	PART NUMBER	DESCRIPTION
0	K23-180-00 K23-181-00	LH Complete Brake Assembly RH Complete Brake Assembly
1	036-089-10	Backing Plate Assembly
2	047-107-05 047-108-05	Actuator Lever Arm Assembly, LH Actuator Lever Arm Assembly, RH
3	027.005.00	Wire Clip
4	046.009.00	Retractor Spring
5	K71-127-00	Shoe and Lining Kit
6	043.004.00	Adjuster Assembly
7	046-018-00	Adjusting Screw Spring
8	K71-125-00 042-143-00 027-009-00 046-080-00	Magnet Kit containing: (1) Magnet (Black Wire) (1) Magnet Clip (1) Magnet Spring
9	046.007.00	Plug
10	046.016.00	Wire Grommet
11	005-067-00	Anchor Post Washer
12	006-193-00	Nut Washer Assembly

- #12 Not Included with complete brake assembly. Item Sold Separately.

9.6 Hydraulic Surge Brake Actuator - OPTIONAL

LCT60C/600/650/6000

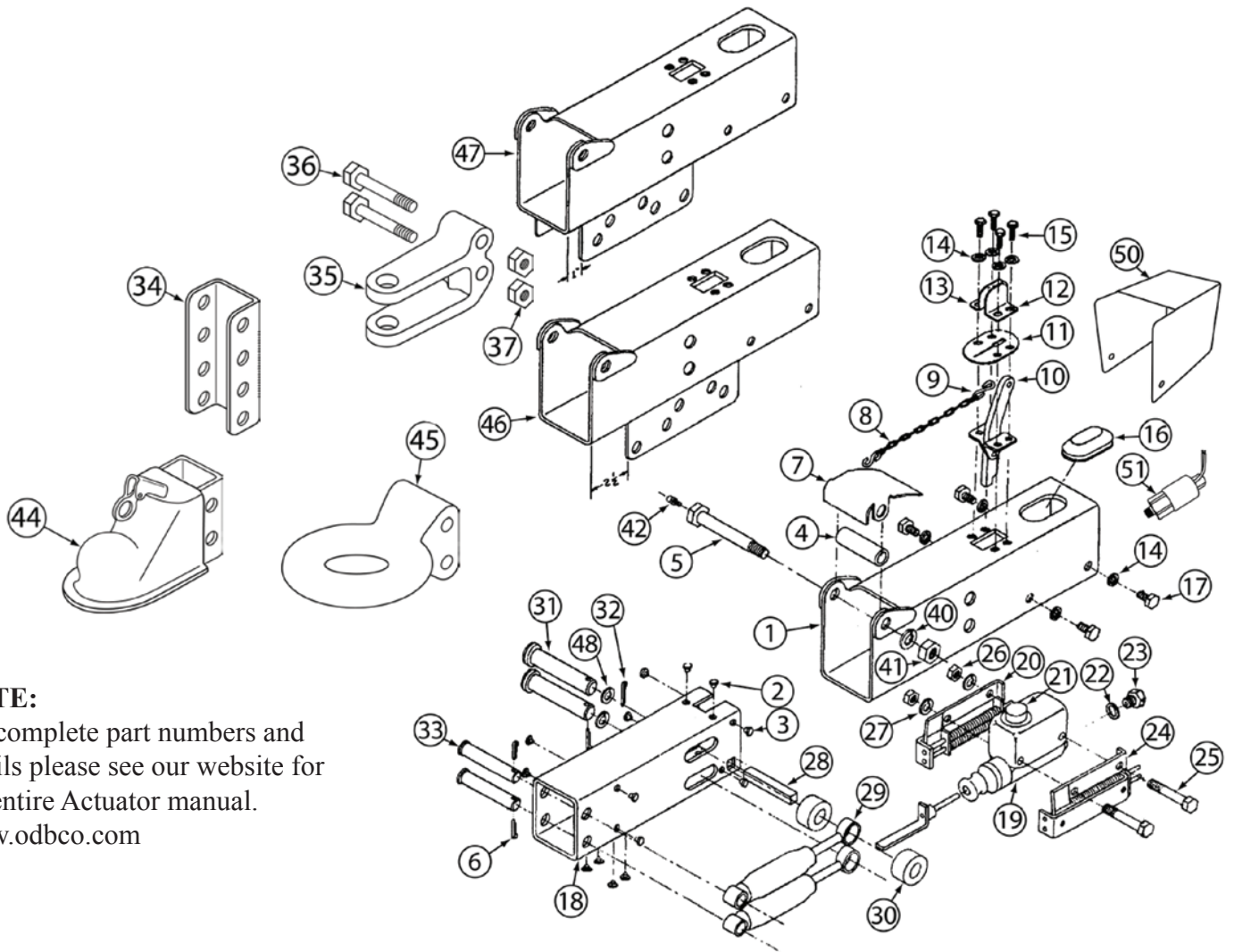

NOTE:

For complete part numbers and details please see our website for the entire Actuator manual.
www.odbco.com

ITEM #	PART NUMBER	DESCRIPTION
*	OD-2404600	Complete Actuator Assembly
4	1601900	Front Roller
7	1601800	Front Roller Cover
10	1054100	Breakaway Lever Assembly
19		Master Cylinder
21	1250300	Filler Cap
24	0838900	Cylinder Bracket, LH
29	1242600	Damper
30	0829100	Rear Roller
51	4748800	Solenoid back up valve

For complete part number listing please see our support section at www.odbco.com



10-0

10.0 HOSE BOOM GROUP

10.0 HOSE BOOM GROUP

10-0	113
10.1 Boom Group.....	114
10.2 Intake Hose Group	115
10.3 M3219 Hydraulic Boom Pump.....	116
10.4 Curb Nozzle Assembly- OPTIONAL	117

HOSE BOOM GROUP

ODB COMPANY
5118 Glen Alden Drive
Richmond, VA 23231
800-446-9823

10.2 Intake Hose Group

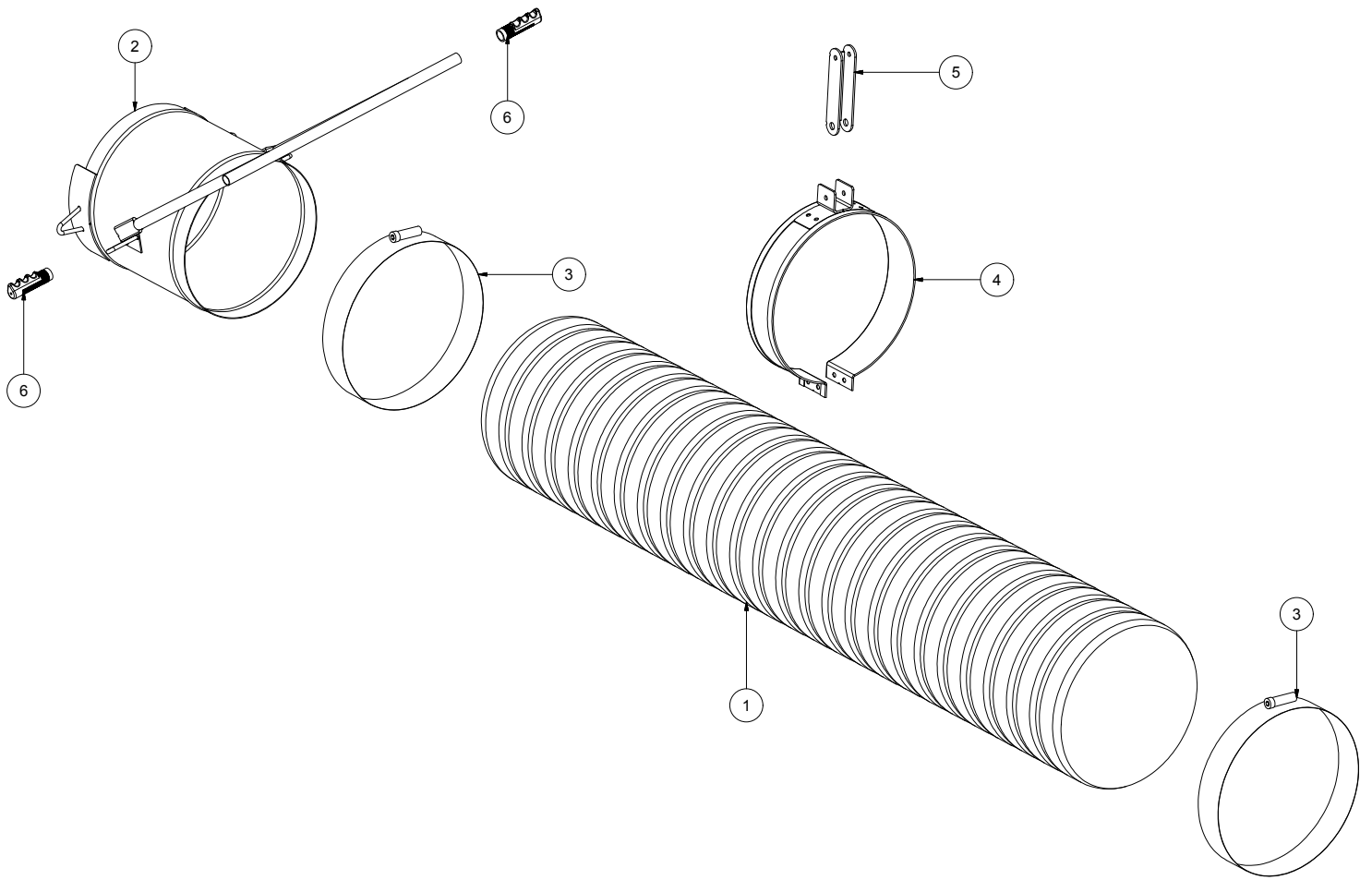

ITEM #	PART NUMBER	DESCRIPTION
1	LC-MDH.16.120 LC-SDH.16.120.UC LC-MDH.16.100	Intake Hose, except SCL Intake Hose, Urethane (multi-axis) Intake Hose, SCL800
2	LCT616.601	Intake Nozzle
3	LCT616.616	Hose Band, Bolt Style
4	LCT616.603U LCT616.603U.B	Hose Clamp, 3/8" thick hoses Hose Clamp, urethane hoses
5	LCT616.607	Hose Support Hanger
6	SCL670.5	Grip

10.3 M3219 Hydraulic Boom Pump

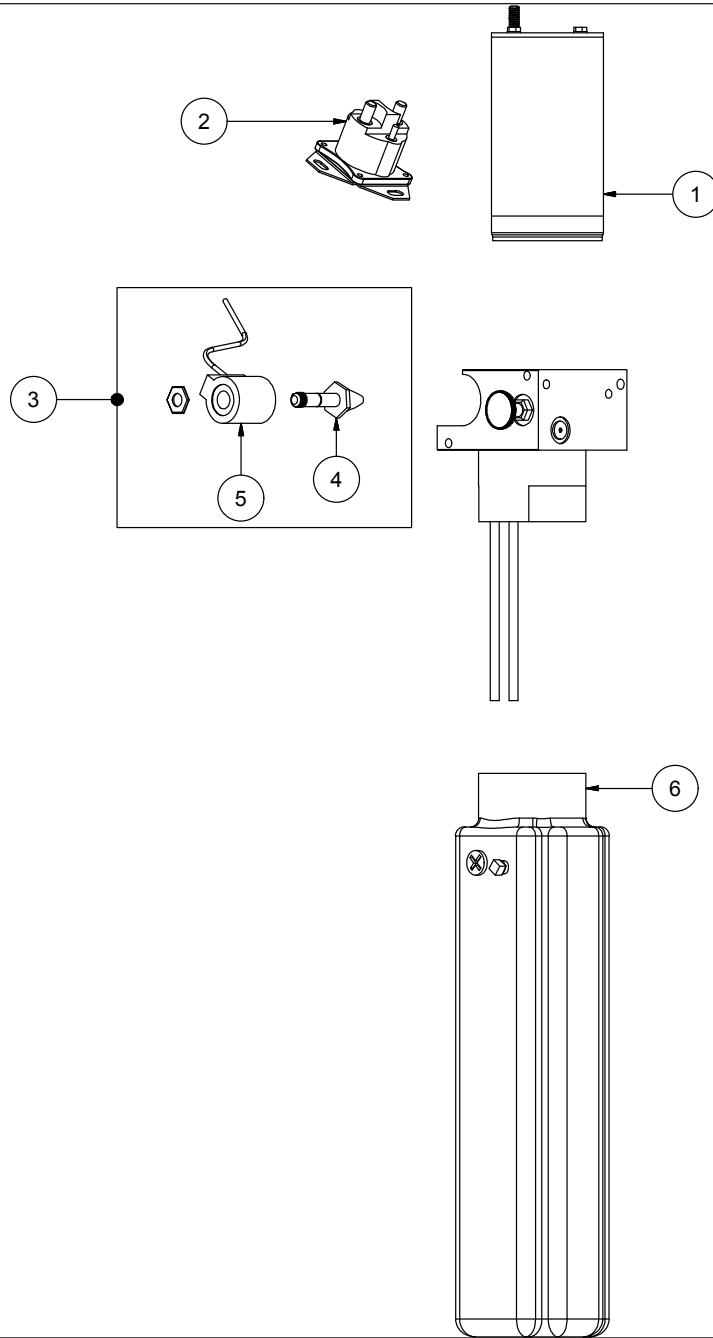

ITEM #	PART NUMBER	DESCRIPTION
	MP-M3219.S	Complete Pump Assembly (all above)
1	MP-08004	Electric Motor, 12V
2	MP-17744	Solenoid Switch, heavy duty
3	MP-19283D	Coil, Cartridge Assembly
4	MP-07193.D	Cartridge
5	MP-10861.D	Coil, 2 way - 2 position
6	MP-06232	Plastic Reservoir, 3.5" x 15.7"

10.4 Curb Nozzle Assembly- OPTIONAL

03/98 and after

Entire Assembly (includes 1-29):
OD-600CN.03

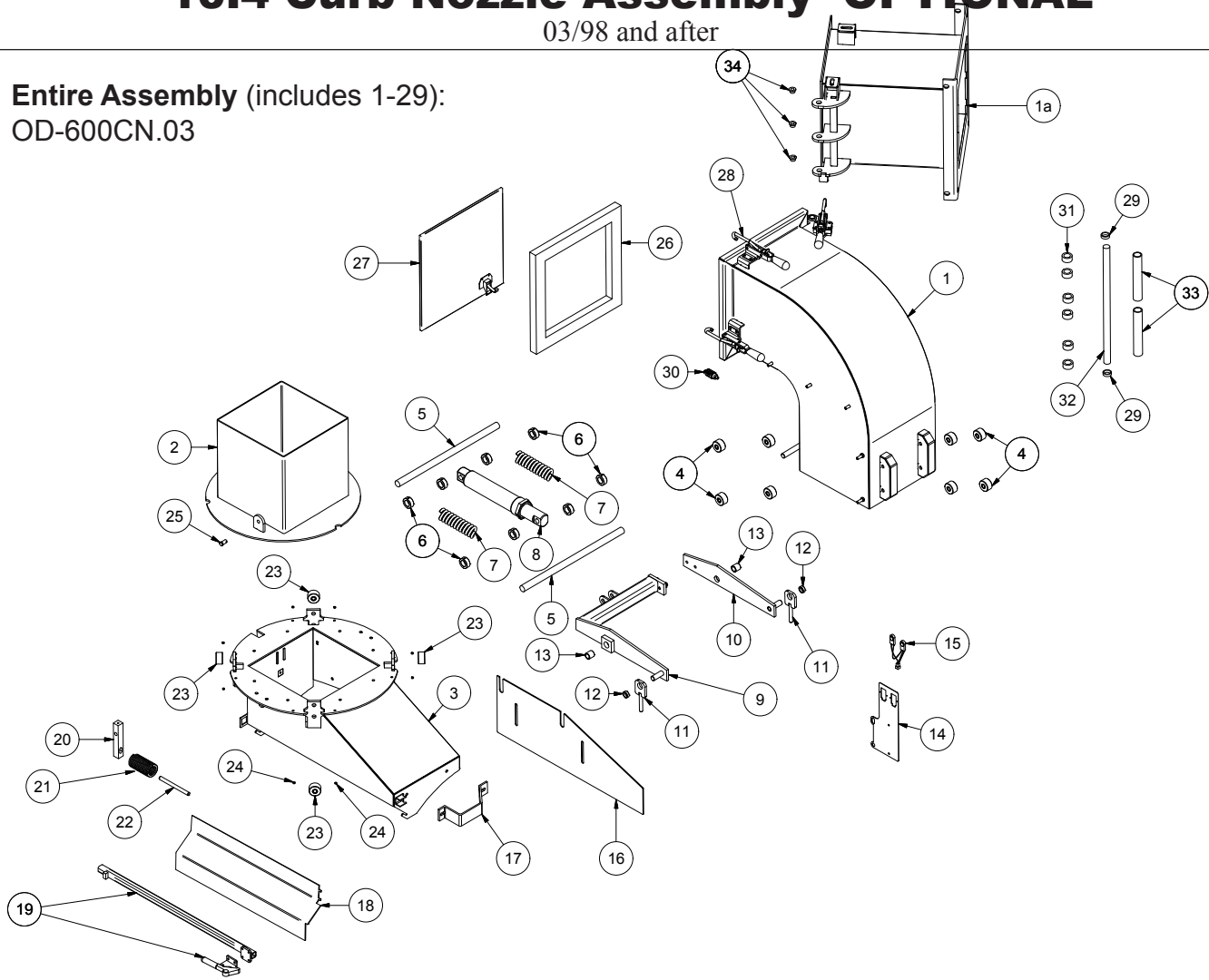

ITEM #	PART NO.	DESCRIPTION	ITEM #	PART NO.	DESCRIPTION
*	600CN.03	Entire Assembly	17	LCT675.002	Bumper
1	LCT672.001	Curb Nozzle Elbow	18	LCT678	Deflector Shield
1a	LCT672.001.1 LCT672.001.1A	Intake Flange, LCT600 Intake Flange, LCT6000	19	LCT678B LCT678C	Lock Rod For Sheild Destaco Clamp For Above
2	LCT674	Telescoping Duct	20	LCT688	Adjustment Bar
3	LCT675.A	Nozzle Foot	21	LCT689	Adjustment Spring
4	LCT685.A	Roller Bearing, 1.75"	22	LCT690	Adjustment Threaded Rod
5	LCT686	Shaft	23	LCT685	Roller Bearing, 1.75"
6	211106	Set Collar, 5/8"	24	LCT676	Roller Bearing, 1"
7	LCT679	Spring	25	LCT667	Clevis Pin, 1"
8	LCT680	Hydraulic Cylinder	26	LCT672.002	Gasket
9	LCT677	Leverage Arm, RH	27	LCT672.004	Safety Cover
10	LCT677A	Leverage, LH	28	LCT672.003	Clamp
11	LCT687	Clevis Arm	29	LCT672.005	Set Collar For Hinge Pin
12	LCT696	Brass Bushing 1"OD x .75"ID x .375"	30	LCT690.601.A	Limit Switch
13	LCT697	Brass Bushing 1"OD x .75"ID x 1"	31	LCT672.007	Brass Bushing For Hinge Pin
14	LCT665	Up/Down Switch Bracket	32	LCT672.006	Hinge Pin
15	STD.2321C	Up/Down Buttons	33	LCT672.008	Spacer Tube For Hine Pin
16	LCT675.001	Front Deflector	34	LCT695	Bronze Flange Bushing 1"OD x .5"ID



11-0

MULTI-AXIS BOOM SECTION (OPTIONAL)

MULTI-AXIS BOOM SECTION (OPTIONAL)

11-0	118
11.1 (2 or 3X) Hydraulic Tank - Valve Body Group.....	119
11.2 Joystick Group - 2 Axis Boom.....	120
11.3 (2 Axis) Boom Assembly	121
11.4 (3 Axis) Boom Assembly	122
11.5 Hinged Boom Frame Assembly	123
11.6 Auburn Gear Drive Assembly - 3 Axis	124
11.7 2 Section Valve Body	125
11.8 4 Section Valve Body	126
INDEX	
Index	128

Multi-Axis Boom Section - OPTION

ODB Company
5118 Glen Alden Drive
Richmond, VA 23231
800-446-9823

11.1 (2 or 3X) Hydraulic Tank - Valve Body Group

LCT600 / 6000 multi-axis units - January 2006 and after

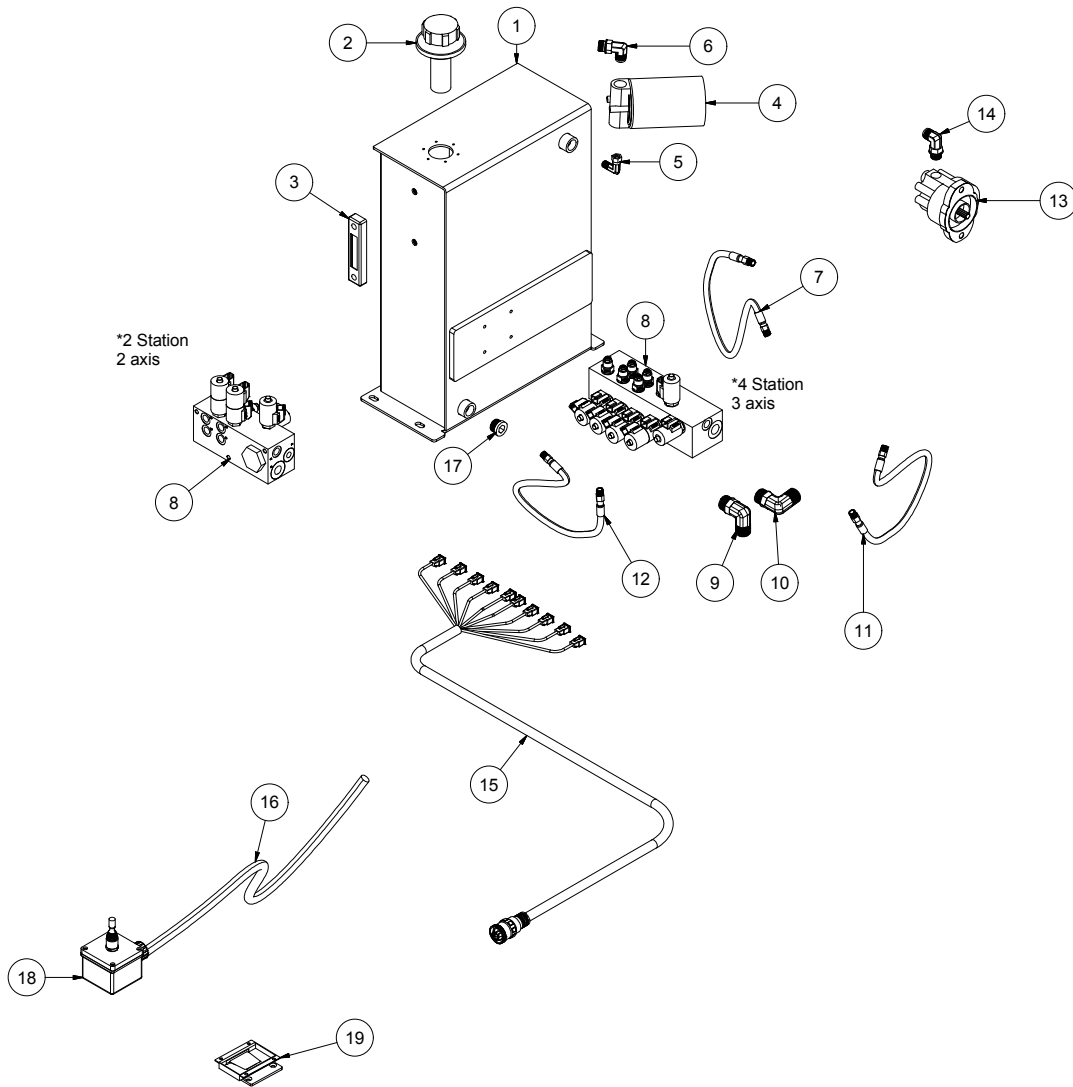

Notes: All hydraulic hoses and wiring harness are special and have to be made up to fit the particular application.

ITEM #	PART NUMBER	DESCRIPTION	ITEM #	PART NUMBER	DESCRIPTION
1	600.2401	Hydraulic Tank	13	STD.9015 650.142	Hydraulic Pump, Double Valve Hydraulic Pump, Single Valve
2	800.2005	Filler Cap	14		90 Degree Fitting
3	SCL.5CT1214	Site Guage	15	Varies	Wiring Harness to Valve Body
4	800.2003 800.2004	Hydraulic Filter Assembly Filter Only	16	Varies	Wiring Harness To Joystick Fitting To Tank
5		90 Degree Fitting To Tank	17		Fitting to tank
6		90 Degree Fitting	18	800.950 800.900	Joystick Assembly, Single Joystick Assembly, Dual
7	*Hose*	Hydraulic Hose, 1/2"	19	800.952	Single Joystick Holder
8	STD.9057 550.1700B	Valve Body 2 Section Valve Body 4 Section			
9		90 Degree Fitting			
10		90 Degree Fitting			
11	*Hose*	Hydraulic Hose, 1/2"			
12	*Hose*	Hydraulic Hose, 1/2"			

11.2 Joystick Group - 2 Axis Boom

LCT600 / 6000 multi-axis units - January 2006 and after

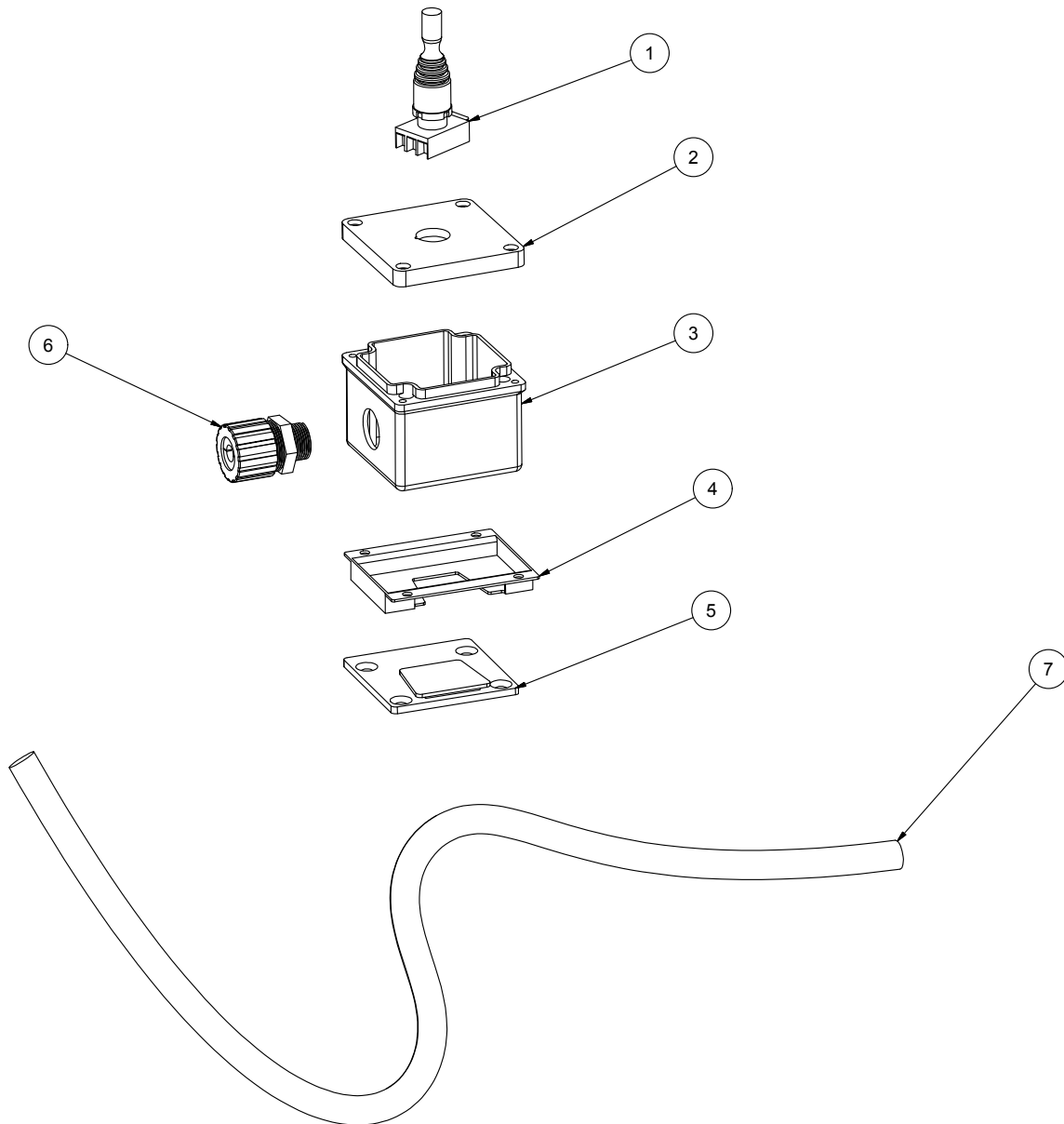

ITEM #	PART NUMBER	DESCRIPTION
1	800.903	Joystick
2	800.951	Box Cover
3	800.951	Box
4	800.952	Box Bottom, comes with #5
5	800.952	Box Holder, comes with #4
6	800.953	Grip Fitting, strain relief
7		Wiring Harness

11.3 (2 Axis) Boom Assembly

(2010 thru present)

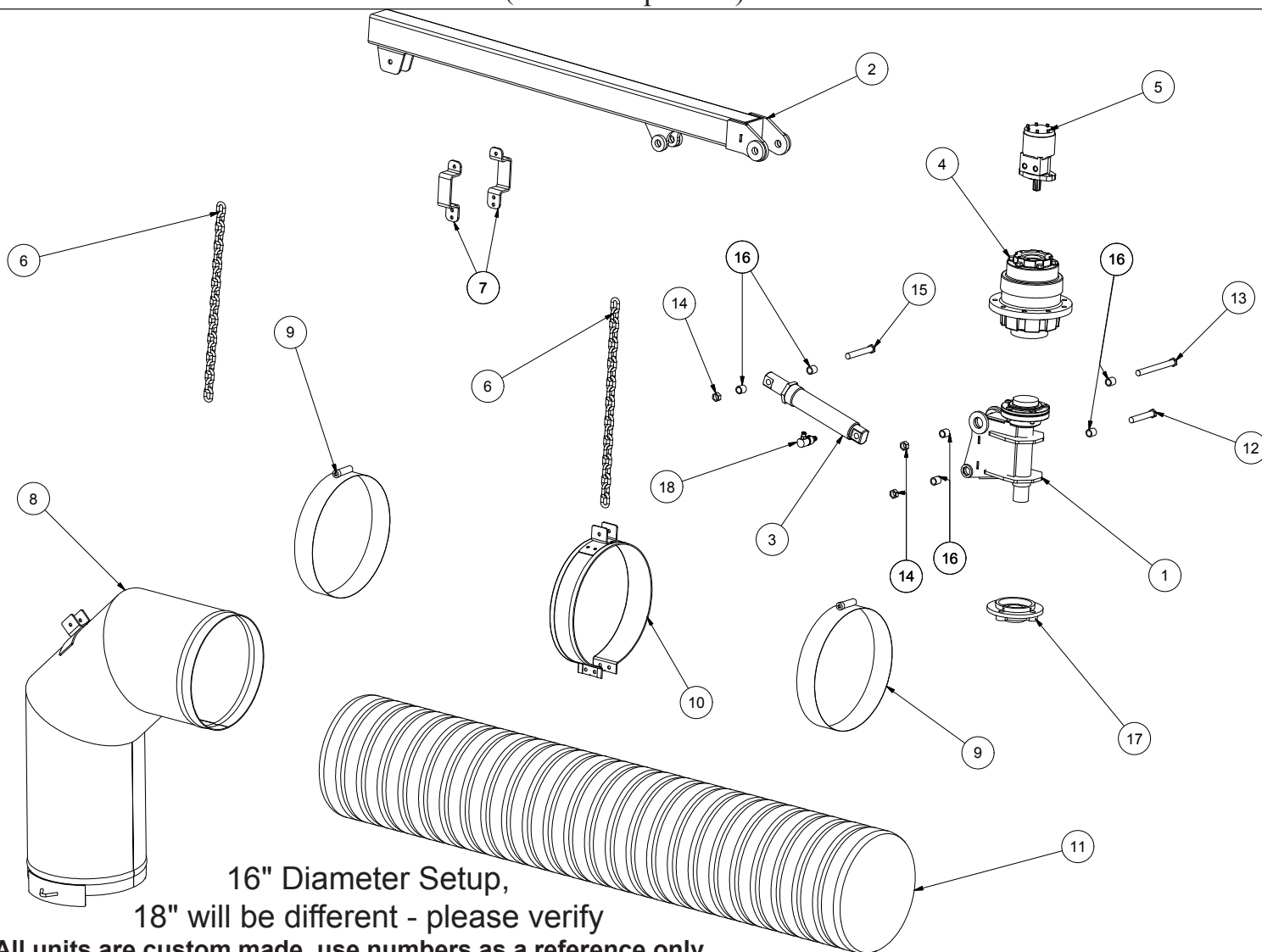

16" Diameter Setup,
18" will be different - please verify

*All units are custom made, use numbers as a reference only.

ITEM #	PART NO.	DESCRIPTION
1	800.707B	Boom Mast
2	LCT616.606MA.3 LCT616.606MA.4	Boom Arm, 2 Axis when using 90 degree nozzle Boom Arm, 2 axis when using standard nozzle
3	SCL816.812	Boom Cylinder
4	800.704B	Auburn Gear
5	800.701D	Hydraulic Motor
6	Call	Chain
7	LCT622.635	Boom Hanger Bracket
8	LCT616.601.90MA	90 Degree Nozzle

ITEM #	PART NO.	DESCRIPTION
9	LCT616.616	Hose Clamp
10	LCT616.603U	Hose Support
11	Varies, please call	Intake Hose
12	800.708	Bolt, 3/4-16 x 4.5" Long
13	800.710	Bolt, 3/4-16 x 7.5" Long
14	800.712	Nut, 3/4"
15	800.709	Bolt, 3/4-16 x 5" Long
16	8X.002E	Bushing, .75"x.375ODx1
17	800.609	Bearing
18	HYF.1028.M	Fitting, 90 degree swivel

11.4 (3 Axis) Boom Assembly

(2010 thru present)

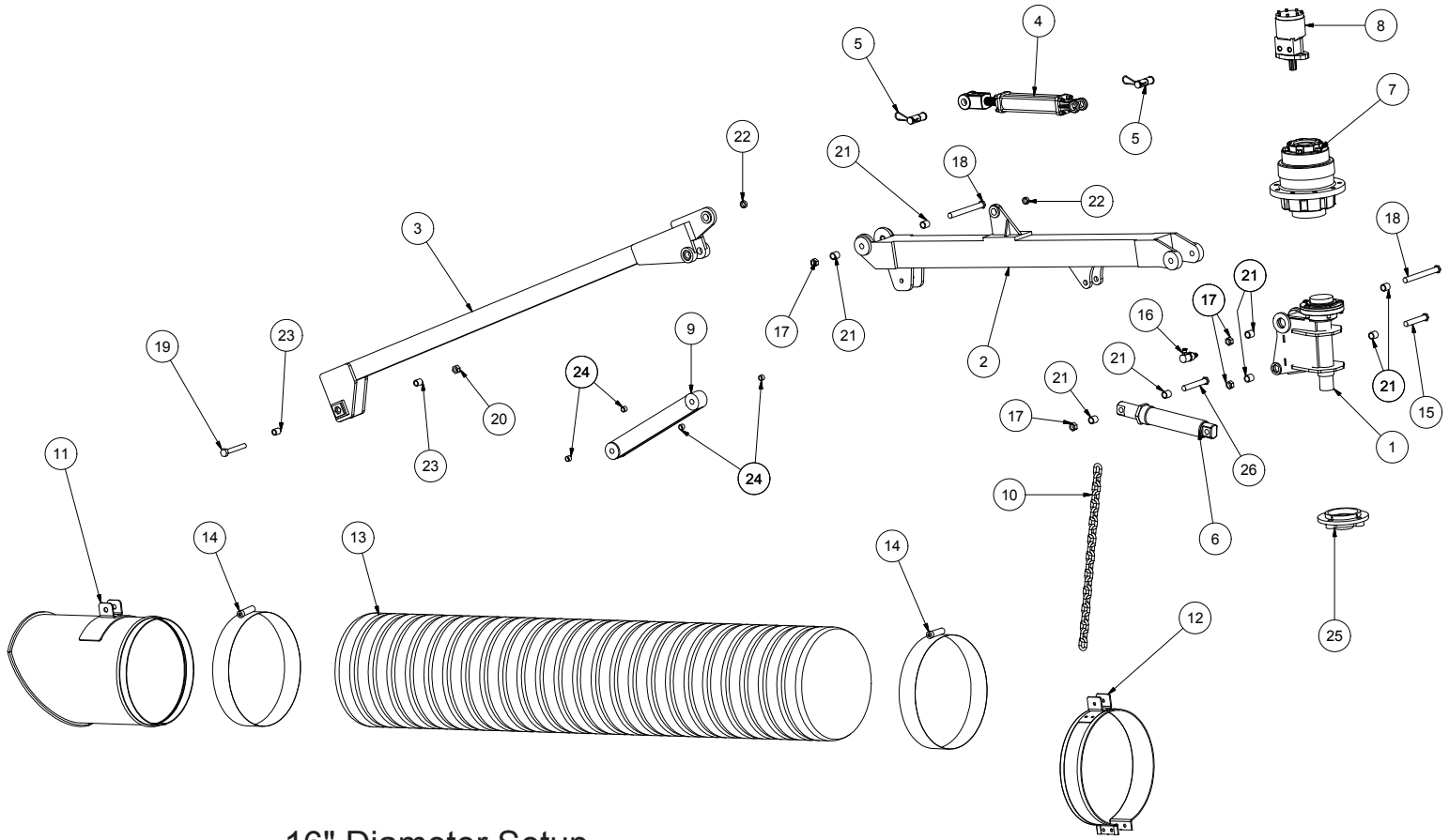

16" Diameter Setup,

18" will be different - please verify

*All units are custom made, use numbers as a reference only.

#	PART NO.	DESCRIPTION	#	PART NO.	DESCRIPTION
1	800.707B	Boom Mast	14	LCT616.616	Hose Clamp
2	LCT616.606MA.2	Boom Arm, Up/Down	15	800.708	Bolt, 3/4-16 x 4.5" Long
3	LCT616.606MA.1	Boom Arm, In/Out	16	HYF.1028	Fitting, 90 degree swivel
4	SCL816.810	Cylinder, In/Out	17	800.712	Nut, 3/4"
5	SCL816.814	Pin	18	800.710	Bolt, 3/4-16 x 7.5" Long
6	SCL816.812	Cylinder, Up/Down	19	800.711	Bolt, 5/8-11 x 4.5" Long
7	800.704B	Auburn Gear	20	800.713	Nut, 5/8"
8	800.701D	Hydraulic Motor	21	8X.002E	Bushing, .75"IDx1"ODx1"
9	SCL816.813 SCL816.813.24	Hose Support Tube, 18" Hose Support Tube, 24"	22	8X.002G	Bushing, 1"IDx.375"ODx1"
10	Call	Chain	23	8X.002F	Bushing, .625"IDx.875"ODx1"
11	LCT616.601.A.HD	Nozzle, 45 degree	24	8X.002D	Bushing, .625"IDx.75"ODx.5"
12	LCT616.603U	Hose Support Band	25	800.609	Bearing
13	SDH.16.120.UC	Intake Hose, 10' Long	26	800.709	Bolt, 3/4-16 x 5" Long

11.5 Hinged Boom Frame Assembly

2or 3 Axis units July 2005 and after

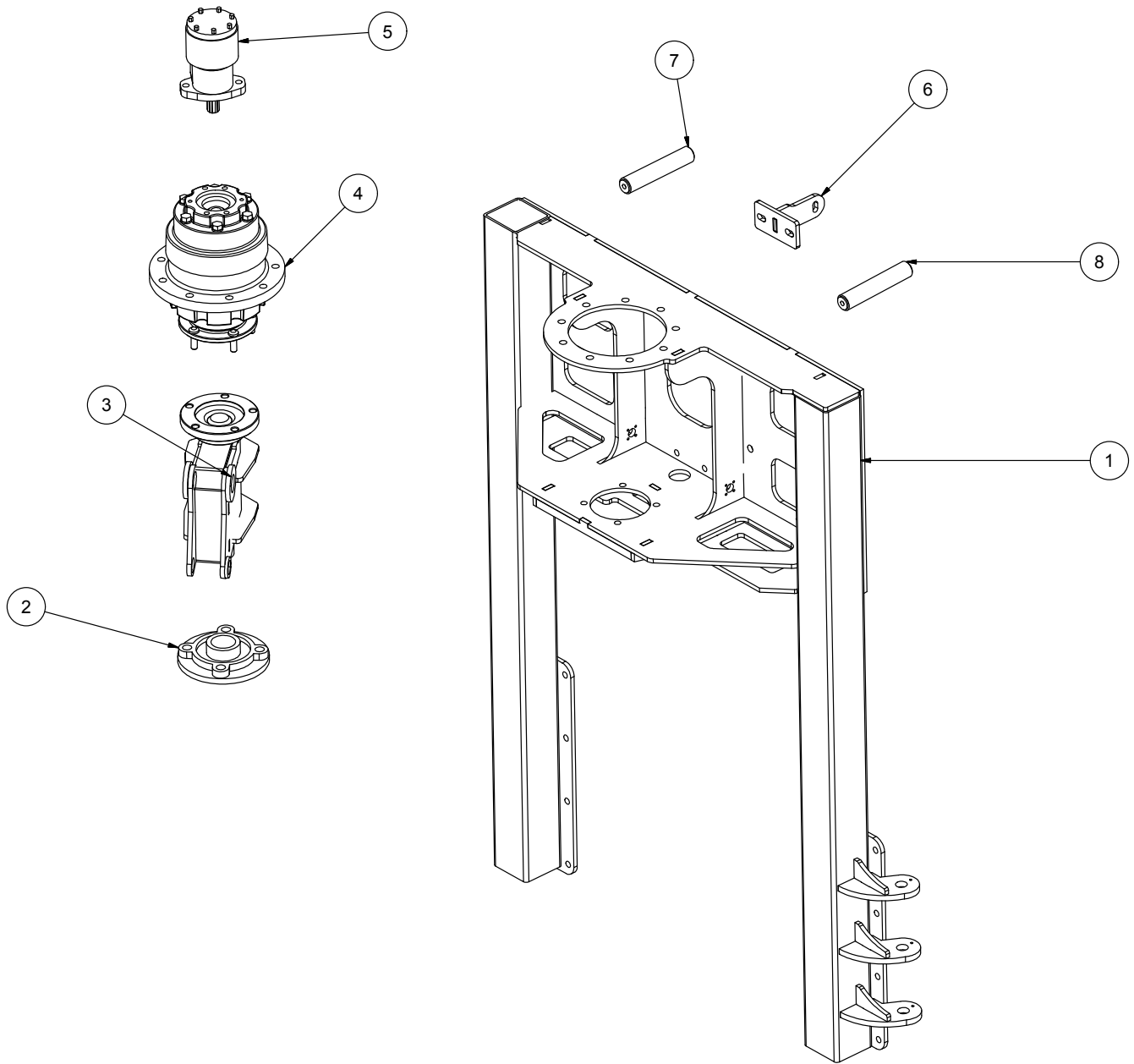

ITEM #	PART NUMBER	DESCRIPTION
1	800.600C	Boom Frame
2	SCL816.501	Bearing
3	800.707A	Boom Mast, Knuckle
4	800.704B	Auburn Gear (see breakdown next page)
5	800.801D	Hydraulic Motor
6	800.609	Frame Support
7	SCL816.503L	Boom Stop, LH
8	SCL816.503R	Boom Stop, RH

11.6 Auburn Gear Drive Assembly - 3 Axis

3 Axis units May 2010 and after

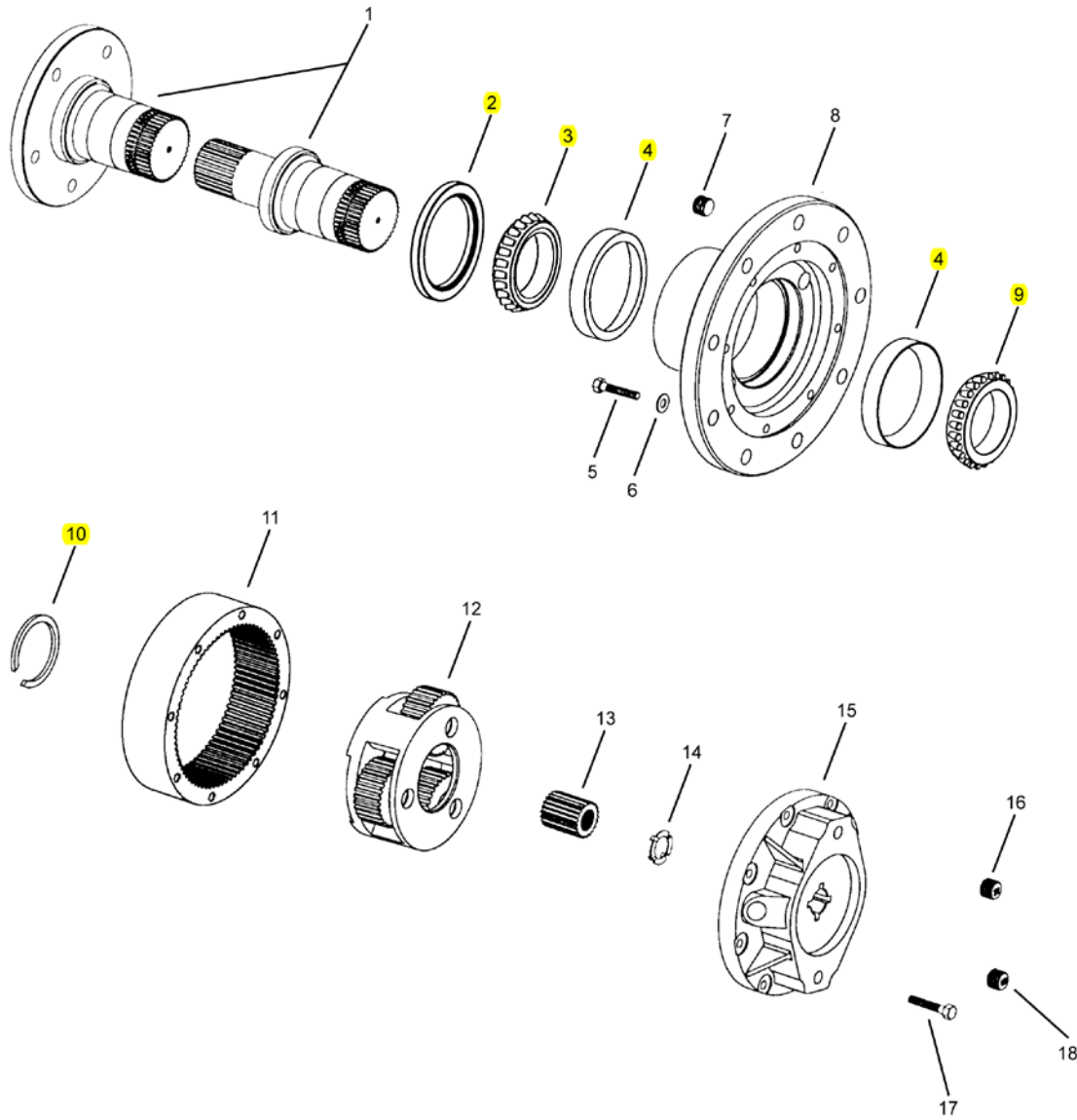

ITEM #	PART #	DESCRIPTION
1		Output Shaft or Spindle
2	14-00-044-010	Oil Seal
3	14-01-101-35	Bearing Cone
4	14-01-102-12	Bearing Cup
5		Hex Head Bolt (grade 8)
6		Flat Washer
7	03-04-101-09	Pipe Plug
8		Hub
9	04-01-101-17	Bearing Cone
10	14-02-410-003	Retaining Ring Kit
11		Ring Gear

ITEM #	PART #	DESCRIPTION
12		Carrier Assembly
13		Sun Gear
14		Thrust Washer
15		Cover
16	14-00-052-002	Magnetic Plug
17		Hex Head Bolt
18	03-04-101-01	Pipe Plug
*	641008	Bearing and Seal Kit, includes #2,3,4,8 and 10
*	641017	Seal Kit, includes #2 & #10

11.7 2 Section Valve Body

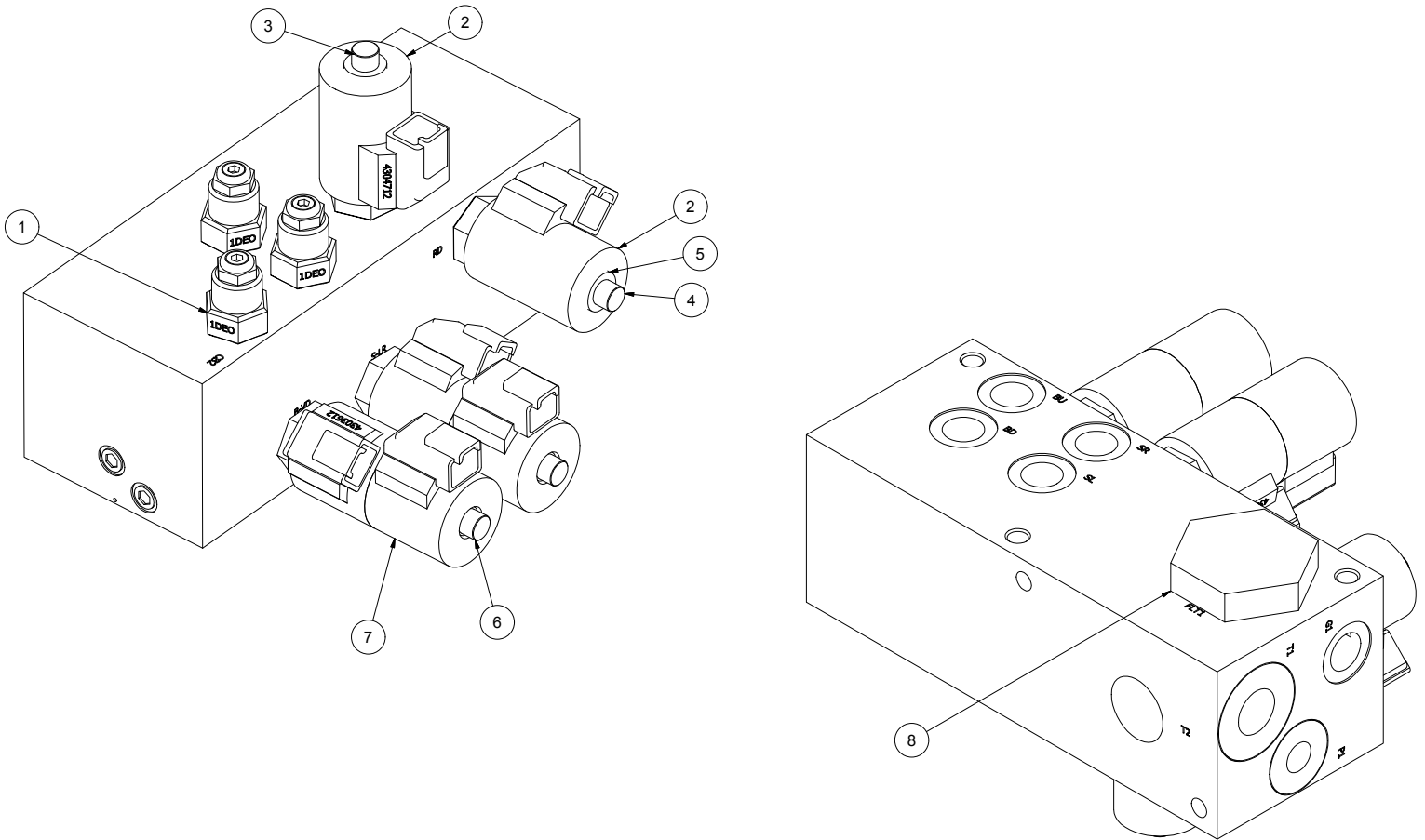

ITEM #	PART NO.	DESCRIPTION
	STD.9057	Entire Assembly
1	550.1704	Counter Balance Valve
2	TCC.1100Q	Deadman/Relief Funtioin Coil
3	TCC.1100D	Deadman Valve Cartridge
4	550.1705	Vented Relief Valve Cartridge
5	550.1703	Nut for #4
6	550.1706	Boom Funtion Valve Cartridge
7	TCC.1100R	Boom Funtion Coil
8	550.1710 800.529B	Filter Cartridge Filter

11.8 4 Section Valve Body

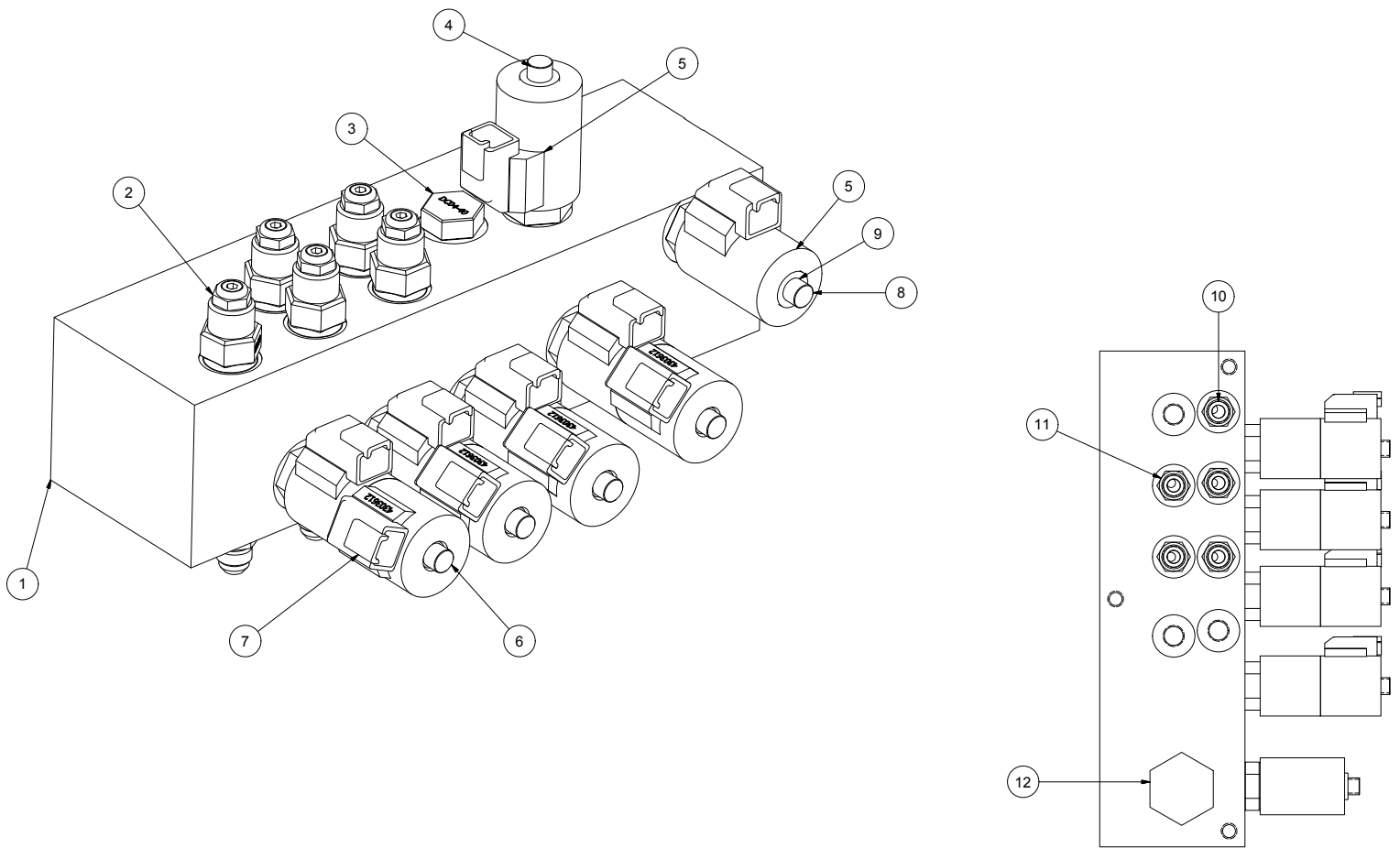

ITEM #	PART NO.	DESCRIPTION
	550.1700B	Entire Assembly
1	550.1700	4 Station Block
2	550.1704	Counter Balance Valve
3	TCC.1100F	Check Valve
4	TCC.1100D	Deadman Valve Cartridge
5	TCC.1100Q	Deadman/Relief Function Coil
6	550.1706	Boom Function Valve Cartridge
7	TCC.1100R	Boom Function Coil
8	550.1705	Vented Relief Valve Cartridge
9	550.1703	Nut for #8
10	550.1707	Flow Control Orifice .040
11	550.1708	Flow Control Orifice .045
12	550.1710 800.529B	Filter Cartridge Filter

SAFETY PRECAUTIONS

⚠️ WARNING

Read and understand this entire manual before operating, maintaining or repairing the leaf vacuum.



⚠️ DANGER

DO NOT RIDE, SIT OR STAND ON UNIT.

**RIDING ON UNIT
COULD RESULT IN BODILY
HARM OR FATAL INJURY
USE EXTREME CAUTION WHEN
UNIT IS IN USE, OR IN MOTION.**

If the decal above is missing or damaged call ODB immediately and we will send you a replacement free of charge. Never operate a unit with damaged or missing safety decals.

⚠️ DANGER

DO NOT RIDE, SIT OR STAND ON UNIT

⚠️ DANGER

DO NOT MODIFY THE UNIT FOR RIDERS IN ANY WAY. SERIOUS INJURY OR DEATH MAY OCCUR

ODB's leaf collectors are NEVER to be used to accommodate riders. If your unit has been modified to accommodate riders, remove these modifications immediately as this can result in serious injury or death.

INDEX

A

Access Door 77
Air Cleaner 75
Air Deflector 86
Alignment Tool 90
Axle Hub 107

B

Battery 83
Battery Cable, 82
Battery Tray 82
Bearing, PTO 89
Bearing Retainer Cover 89
Blower Housing Face 98
Boom Bearing 98
Boom Frame 120
Boom Pump 111
Boom Stop 120

C

Cartridge 113
Chaffe Eliminator 86
Clip Spring 90
Clutch Bracket Arm 91
Clutch Cable 85
Clutch Cover 88
Clutch Cylinder 91
Clutch Disk 88
Clutch Handle 90
Coil 113
Cylinder 111
Cylinder, Clutch 91

D

Disk, Clutch 88
Door 77

E

Engine Mount 78

F

Fan, Chaffe 86
Fan Shroud 80
Filter 75
Filter Element 75
Flange Bearing 86
Fluid Drive 93, 94, 95

G

Grommet 77
Grommet 76

H

Hood 74, 77

I

Intake Flange 98

K

Key, Stepdown 89
Knuckle 120
Kraft Fluid Drive 92

L

Latch, Lift and Turn 77
L.E.D. Light Assembly
Lift and Turn Latch 77
Limit Switch 85, 98
Linkage 90, 91
Linkage Bracket 90
Linkage Rod 90
Lock Rod 98

M

Mounting Bands 75
Muffler 79

O

Oil Fill Door 77
Oil Pressure Switch 81
Oil Temperature Sender 81
Overcenter Latch 77

P

Panel Door 77
Pilot Bearing 88
Pivot Shaft 91
Pre-Cleaner 75
Pressure Plate 88
PTO Assembly 89
PTO, Fluid Drive 94, 95

R

Radiator 80
Radiator Access Door 77
Radiator Cap 80
Radiator Fan 80
Radiator Hose 80
Radiator Screen 77
Rail 78
Rake Rack 98
Remote Clutch 84
Adaptor 84

Cable 84
Remote Throttle 84
Return Spring 90
Rocker Ball 90
Rocker Switch 76

S

Sender
Oil Pressure 81
Water Temperature 81
Shaft Bushing, PTO 90
Shaft, Lever 90
Shaft, PTO 89
Side Rail 78
Starter Solenoid 83
Strobe Light 76
Switch
Oil Pressure 81
Water Temperature 81
Switch Harness, Cold Start
Switch Harness, Remote PTO
Switch Harness, Remote Throttle
Switch Harness, Safety Light

T

Terminal Cover 82
Throttle Cable 85
Throttle Connector 83
Throw out Bearing, 88
Torque Coupling 85

U

Up/Down Switch 111

W

Water Temperature Sender 81
Wiring Harness 76
Wiring Harness, Switch 76

INDEX



CAUTION

**DO NOT ATTEMPT TO OPERATE
OR REPAIR
THE LEAF COLLECTOR WITHOUT FIRST
READING AND UNDERSTANDING THIS
MANUAL**

IF YOU HAVE ANY QUESTIONS CONCERNING THE
INSTALLATION OR OPERATION OF THIS UNIT, PLEASE CALL
ODB FOR ASSISTANCE BEFORE ATTEMPTING TO REPAIR OR
OPERATE THE UNIT.

**IMPROPER USE OF ANY MACHINE CAN
RESULT IN SERIOUS INJURY!**

**STUDY AND FOLLOW ALL SAFETY
PRECAUTIONS BEFORE OPERATING OR
REPAIRING UNIT**

THIS MANUAL IS AN INTEGRAL PART OF THE LEAF COLLECTOR AND SHOULD
BE KEPT WITH THE UNIT WHEN IT IS SOLD.

ODB COMPANY
5118 Glen Alden Drive
Richmond, VA 23231
800-446-9823

