

LCT600

Belt Driven Leaf Collector



**Owner's Manual
Safety Manual
Pre-Operating Manual
Operating Manual
Maintenance Manual
Service Manual
Parts Catalog**

ODB Company
5118 Glen Alden Drive
Richmond, VA 23231
800-446-9823
www.leafcollector.com





CAUTION

DO NOT ATTEMPT TO OPERATE
OR REPAIR
THE LEAF COLLECTOR WITHOUT FIRST
READING AND UNDERSTANDING THIS
MANUAL

IF YOU HAVE ANY QUESTIONS CONCERNING THE
INSTALLATION OR OPERATION OF THIS UNIT, PLEASE CALL
ODB FOR ASSISTANCE BEFORE ATTEMPTING TO REPAIR OR
OPERATE THE UNIT.

IMPROPER USE OF ANY MACHINE CAN
RESULT IN SERIOUS INJURY!

STUDY AND FOLLOW ALL SAFETY
PRECAUTIONS BEFORE OPERATING OR
REPAIRING UNIT

THIS MANUAL IS AN INTEGRAL PART OF THE LEAF COLLECTOR AND
SHOULD BE KEPT WITH THE UNIT WHEN IT IS SOLD.

ODB COMPANY
5118 Glen Alden Drive
Richmond, VA 23231
800-446-9823



TABLE OF CONTENTS

 **WARNING**

Read and understand this entire manual before operating, maintaining or repairing the leaf vacuum.

SAFETY, OPERATING AND MAINTENANCE TABLE OF CONTENTS

1.0 GENERAL SAFETY

- 1.1 Safety Symbol Definitions
- 1.2 Do's and Don't's
- 1.3 Training
- 1.4 Safety Decal Listing and Part Numbers

2.0 PRE-OPERATING SECTION

- 2.1 Instruments and Controls
- 2.2 Safe Operations
- 2.3 Preparation for Operation
- 2.4 Pre-Transport Checks
- 2.5 Protective Equipment and Clothing
- 2.6 Worksite Preparation

3.0 OPERATING SECTION

- 3.1 Starting Engine
- 3.2 Engaging PTO
- 3.3 Vacuuming Leaves

4.0 MAINTENANCE SECTION

- 4.1 Maintenance Overview
- 4.2 Maintenance Interval Chart
- 4.3 Lubrication
- 4.4 Preventative Maintenance
- 4.5 Torque Values
- 4.6 Quick Reference Maintenance Chart

TABLE OF CONTENTS

WARNING

Read and understand this entire manual before operating, maintaining or repairing the leaf vacuum.

SAFETY, OPERATING AND MAINTENANCE TABLE OF CONTENTS, continued;

5.0 SERVICE SECTION

SERVICE AND TROUBLESHOOTING

- Service and Repair
- Engine Electrical Troubleshooting
- Circuit Board Troubleshooting
- Auto PTO Adjustment Guide
- Hydr. Boom Troubleshooting
- Impeller Installation/Removal

WIRING DIAGRAMS

- Engine Wiring Diagram
- Circuit Board Wiring
- Trailer Wiring Diagram
- Boom Pump Wiring Diagram

6.0 PARTS BREAKDOWNS

ENGINE GROUP

- Inst. Panel Breakdown
- Air Cleaner Assembly
- Sheet Metal Assembly
- Engine Exhaust
- Radiator Assembly
- Remote Throttle Ass'y (**OPTIONAL**)
- Chaffe Eleminator (**OPTIONAL**)

CLUTCH GROUP

- Clutch Breakdown
- Auto PTO Breakdown
- Auto PTO Linkage
- Clutch Assist Breakdown

6.0 PARTS BREAKDOWNS, cont.;

BLOWER HOUSING & DRIVE GROUP

- Impeller & Blwr Housing Assembly
- Pedistal & Bearing Assembly
- Blower Housing Face Assembly
- Exhaust Duct Assembly

TRAILER GROUP

- Trailer Bed Assembly
- Tongue Assembly
- Axle Hub Group
- Electric Brake Assembly

HOSE BOOM GROUP

- Hose Boom Assembly
- Intake Hose Assembly
- Hydraulic Pump Assembly

1.0 GENERAL SAFETY

WARNING

Read and understand this entire manual before operating, maintaining or repairing the leaf vacuum.

1.0
GENERAL
SAFETY

1.0 GENERAL SAFETY

- 1.1 Safety Symbol Definitions
- 1.2 Do's and Don't's
- 1.3 Training
- 1.4 Safety Decal Listing and Part Numbers

SAFETY PRECAUTIONS

WARNING

Read and understand this entire manual before operating, maintaining or repairing the leaf vacuum.

1.1 SAFETY SYMBOL DEFINITIONS:

This manual provides the owners/operator with procedures for safe operation, maintenance and repair of ODB's leaf collectors. As with any machine, there are hazards associated with their operation. For this reason safety is emphasized throughout this manual. To highlight specific safety information the following safety definitions are provided to assist the reader.

The purpose of safety symbols are to attract your attention to possible dangers. The safety symbols, and their explanations, deserve your careful attention and understanding. The safety warnings do not by themselves eliminate any danger. The instructions or warnings they give are not substitutes for proper accident prevention measures.

SYMBOL



MEANING

SAFETY ALERT SYMBOL: Indicates danger, warning or caution. Attention is required in order to avoid serious personal injury. May be used in conjunction with other symbols or pictographs.

DANGER

Disregarding this safety warning **WILL** result in serious equipment damage, injury or possible death.

WARNING

Disregarding this safety warning **CAN** result in serious equipment damage, injury or possible death.

CAUTION

Disregarding this safety warning **MAY** result in minor or moderate injury or property damage.

SAFETY PRECAUTIONS

WARNING

Read and understand this entire manual before operating, maintaining or repairing the leaf vacuum.

1.2 DO'S AND DO NOT'S:

This section contains some general safety precautions to do and not to do. This is not an all inclusive list and it is the responsibility of the operator to have proper training and use common sense in work situations.

WARNING

DO NOT:

1. **DO NOT** operate, maintain or repair this unit without having fully read and understood ALL the aspects of this manual.
2. **DO NOT** ride, sit or stand on unit at anytime.
3. **DO NOT** modify the leaf vacuum for any reasons to allow for riders.
4. **DO NOT** operate the unit in a state of disrepair.
5. **DO NOT** operate the unit with ANY guards or safety devices broken, missing, or inoperable.
6. **DO NOT** operate the unit without wearing proper safety equipment.
7. **DO NOT** operate this unit while under the influence of any alcohol or medication.
8. **DO NOT** operate this unit if you have a record of mental instability or dizziness which could result in injury to yourself or others.
9. **DO NOT** operate this unit if you are under 18 years of age.
10. **DO NOT** operate this unit without fully inspecting the unit for any damage or leakage.
11. **DO NOT** operate if the unit has any excessive vibration.
12. **DO NOT** operate unit with the inspection door limit switch damaged or missing.
13. **DO NOT** operate unit unless all hydraulic components such as hoses and fittings have been checked for leakage or damage.
14. **DO NOT** operate unit unless it is properly attached to the tow vehicle.
15. **DO NOT** tow unit without using all the safety chains.
16. **DO NOT** tow unit with a damaged tongue.
17. **DO NOT** fill fuel tank with engine running. Allow engine to cool for 5 minutes before refueling.
18. **DO NOT** operate unit if fuel is spilled or with fuel cap off.
19. **DO NOT** smoke or weld near the unit.
20. **DO NOT** run engine in an enclosed area.
21. **DO NOT** place hands or feet near moving or rotating parts.
22. **DO NOT** operate engine with an accumulation of grass, leaves or other debris on the engine.

SAFETY PRECAUTIONS

WARNING

DO NOT, continued;

23. **DO NOT** run engine with air cleaner removed.
24. **DO NOT** leave leaf machine unattended while in operation.
25. **DO NOT** park machine on steep grade or slope.
26. **DO NOT** vacuum a leaf pile without looking for foreign objects such as metal, glass, plastic or large pieces of wood.
27. **DO NOT** go under raised body without body prop in place for any reason.
28. **DO NOT** collect leaves without the dump body lowered completely.
29. **DO NOT** collect leaves with the rear doors open.
30. **DO NOT** raise dump body near any power lines or low tree branches.
31. **DO NOT** raise dump body on an uneven or soft surface.
32. **DO NOT** lower dump body without a complete visual check of the body area.
33. **DO NOT** raise dump body without wheel chocks placed under the wheels.

WARNING

DO's:

1. **DO** completely read and understand the owner's manual before operating, maintaining or repairing the leaf collector.
2. **DO** follow engine and PTO manufacturer operating and maintenance instructions.
3. **DO** check fuel lines and fittings frequently for cracks or leaks. Replace if necessary.
4. **DO** completely inspect the unit before leaving the service garage.
5. **DO** check the tow tongue each day for cracks.
6. **DO** inspect and be attentive to what is being vacuumed.
7. **DO** check the impeller, liners and blower housing for cracks or holes daily.
8. **DO** remove the negative battery cable before doing any maintenance on the unit.
9. **DO** wear proper safety equipment as described in this manual.
10. **DO** watch for pedestrians, animals and other foreign material when vacuuming leaves.
11. **DO** replace any worn or missing safety stickers immediately.
12. **DO** insert the body prop before going under the raised body for any reason.

SAFETY PRECAUTIONS

1.3 TRAINING:

WARNING

Improper use of the ODB leaf collector CAN result in severe personal injury or death. All personnel using this leaf vacuum must be trained and qualified with all the operations, maintenance, repair and safety procedures defined in this manual.

The warnings and procedures regarding safety in this manual are to be used as a guideline only. It is impossible to cover all the events that could happen in the vacuuming process. For this reason, it is vital that the owner accept the responsibility to implement a training program that will provide every operator or mechanic the basic skills and knowledge to make good judgement in all situations.

This training program must include the entire scope of hazards, precautions and government regulations encountered in the vacuuming process. The program should stress the need for regularly scheduled preventive maintenance and detailed equipment safety checks.

ODB strongly recommends all training programs be documented to ensure all operators and mechanics receive initial training on not just the operation but the safety features of the leaf collector.

SAFETY PRECAUTIONS

1.4 SAFETY DECALS - LCT60C:

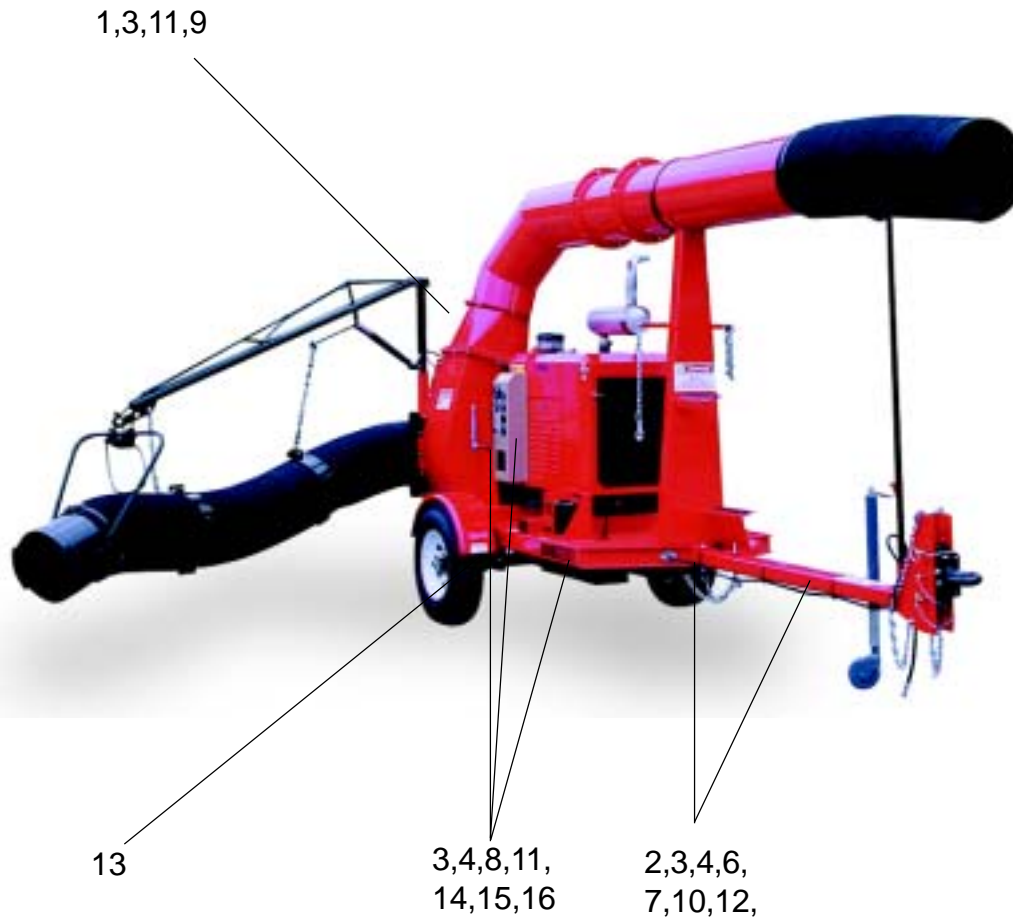

Decals shown at end of section 1.4

ITEM NO.	PART NUMBER	DESCRIPTION
1.	200182	Danger--Do Not Open Cover While in Operation
2.	200179	Danger--Do Not Ride, Sit or Stand on Unit
3.	200181	Danger--Head, Eye and Ear Protection Required
4.	200221	LCT60C Leaf Collector sticker
5.	200109	Do Not Over-Lubricate bearings
6.	200055	Use Diesel Only
7.	200177	Danger--Flammable
8.	200059	Do Not Engage PTO over 1,000 RPM
9.	200183	Danger--Rotating Parts
10.	200178	Danger--Explosion Hazard
11.	200189	Danger--Check Impeller and Liners Daily for Wear
12.	200180	Danger--Inspect Tow Bar for Damage
13.	200104	Warning--Check Lug nuts
14.	200061	ODB leaf collection systems sticker
15.	200120	Throttle decal
16.	200112	Safety Shut off-Ignition decal

SAFETY PRECAUTIONS

1.4 SAFETY DECALS, continued - LCT600/6000

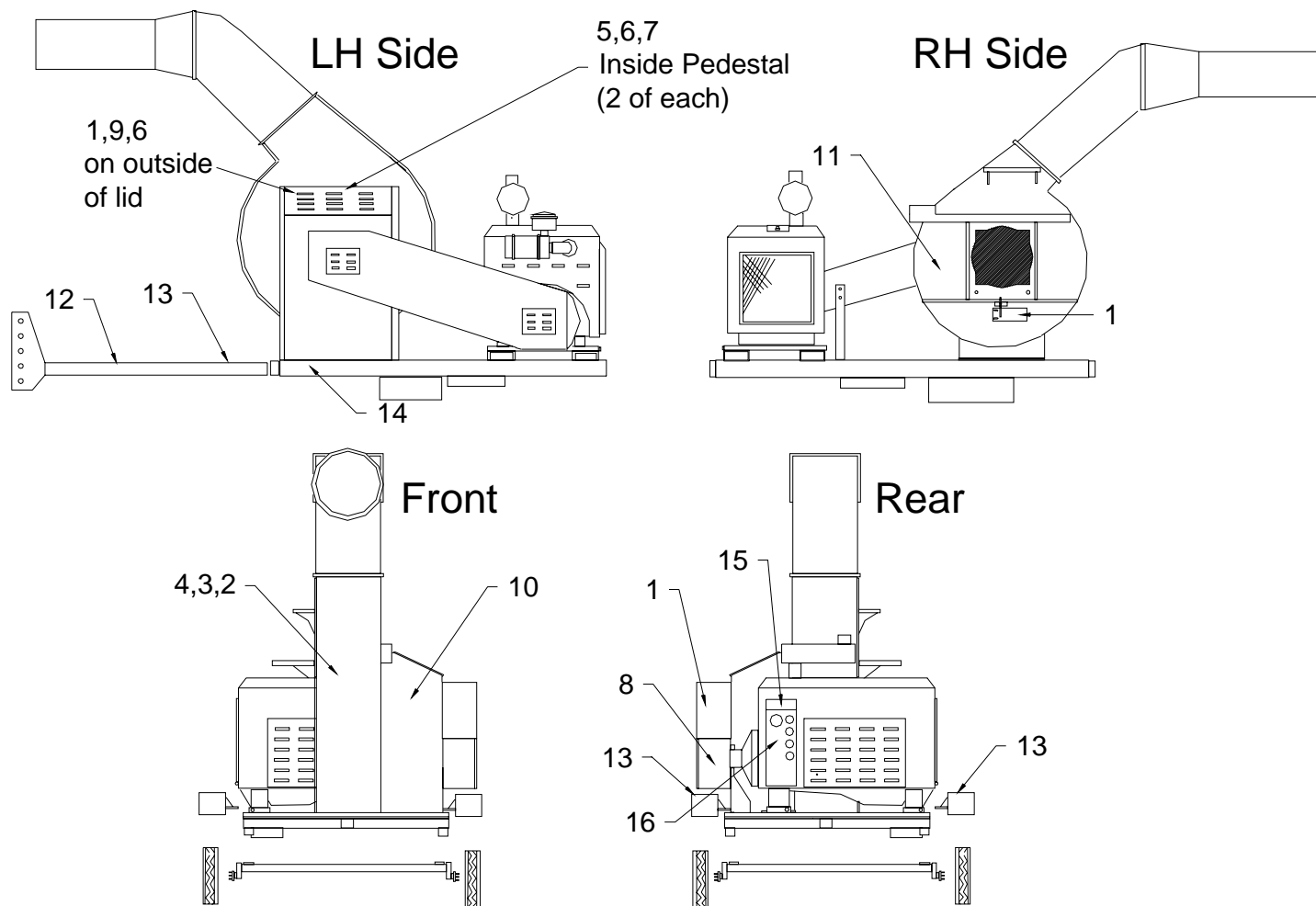

Decals shown at end of section 1.4

ITEM NO.	PART NUMBER	DESCRIPTION
1.	200182	Danger--Do Not Open Cover While in Operation
2.	200179	Danger--Do Not Ride, Sit or Stand on Unit
3.	200181	Danger--Head, Eye and Ear Protection Required
4.	200221	LCT600 Leaf Collector sticker
5.	200109	Do Not Over-Lubricate bearings
6.	200055	Use Diesel Only
7.	200177	Danger--Flammable
8.	200059	Do Not Engage PTO over 1,000 RPM
9.	200183	Danger--Rotating Parts
10.	200178	Danger--Explosion Hazard
11.	200189	Danger--Check Impeller and Liners Daily for Wear
12.	200180	Danger--Inspect Tow Bar for Damage
13.	200104	Warning--Check Lug nuts
14.	200061	ODB leaf collection systems sticker
15.	200120	Throttle decal
16.	200112	Safety Shut off-Ignition decal

SAFETY PRECAUTIONS

1.4 SAFETY DECALS, continued - LCT650

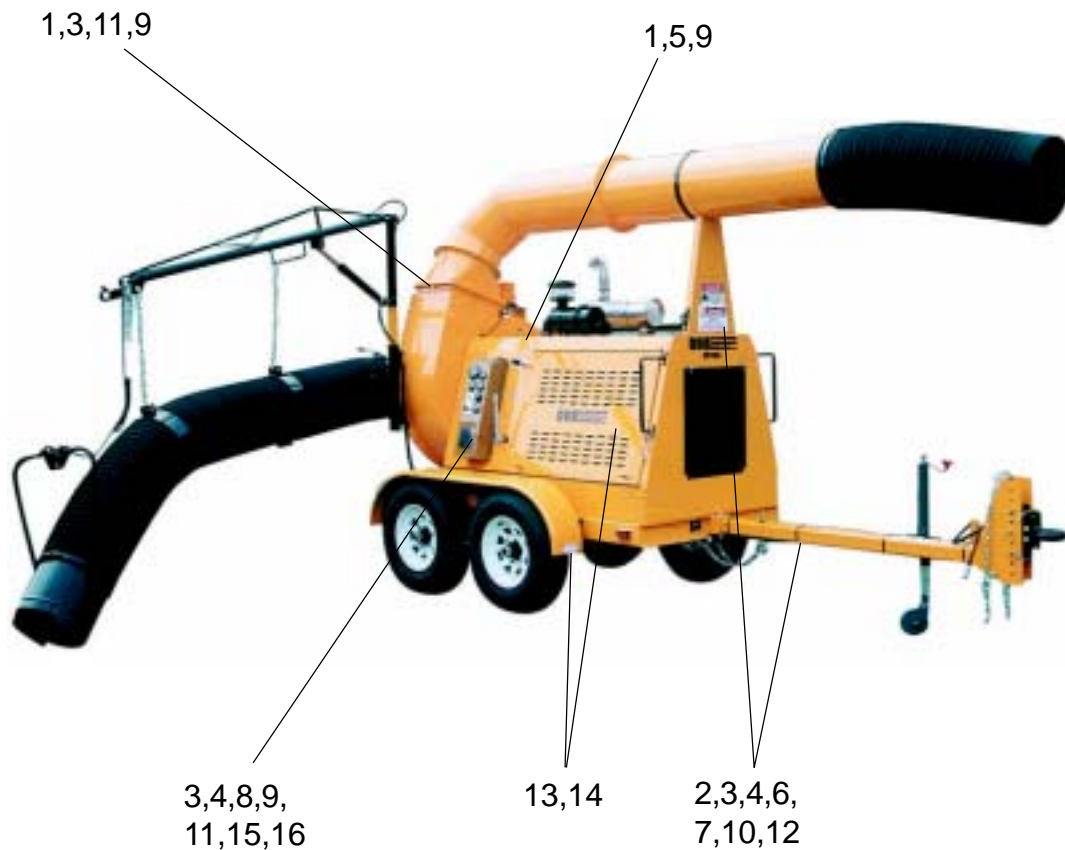

Decals shown at end of section 1.4

ITEM NO.	PART NUMBER	DESCRIPTION
1.	200182	Danger--Do Not Open Cover While in Operation
2.	200179	Danger--Do Not Ride, Sit or Stand on Unit
3.	200181	Danger--Head, Eye and Ear Protection Required
4.	200221	LCT650 Leaf Collector sticker
5.	200109	Do Not Over-Lubricate bearings
6.	200055	Use Diesel Only
7.	200177	Danger--Flammable
8.	200059	Do Not Engage PTO over 1,000 RPM
9.	200183	Danger--Rotating Parts
10.	200178	Danger--Explosion Hazard
11.	200189	Danger--Check Impeller and Liners Daily for Wear
12.	200180	Danger--Inspect Tow Bar for Damage
13.	200104	Warning--Check Lug nuts
14.	200061	ODB leaf collection systems sticker
15.	200120	Throttle decal
16.	200112	Safety Shut off-Ignition decal

SAFETY PRECAUTIONS

1.4 SAFETY DECALS - Decal Layout for LCT60C/600/650/6000

1



9



2



10



3



11



4



12



5



13



6



14



7



15



8



16



2.0 PRE-OPERATING SECTION

WARNING

Read and understand this entire manual before operating, maintaining or repairing the leaf vacuum.

2.0
Pre-Operating
Section

2.0 PRE-OPERATING SECTION

- 2.1 Instruments and Controls
- 2.2 Safe Operations
- 2.3 Preparation for Operation
- 2.4 Pre-Transport Checks
- 2.5 Protective Equipment and Clothing
- 2.6 Worksite Preparation

Pre-Operating Section

(Typical)

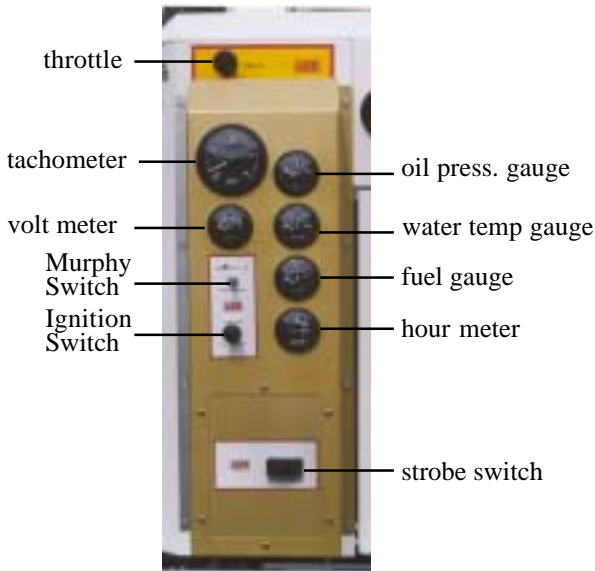

CAUTION

Always make sure the PTO is disengaged before starting unit.

2.1 INSTRUMENTS AND CONTROLS:

Ignition Switch:

Used to power the accessories and start the unit. Unit will not start without Murphy switch depressed.

ACCESSORIES - first position

STARTER ENGAGE - second position (springs return to first position)

Murphy Switch:

This switch overrides the low oil pressure and high temperature cutoff control. This switch must be depressed before the starter engages. After the engine starts, wait for oil pressure to rise before releasing the button.

Throttle:

This control provides positive locking and vernier adjustment of engine.

Tachometer:

This gauge indicates the engine r.p.m.'s. The sender is located on the engine block

Volt Meter:

The gauge shows the status of the engine charging system. When the charging system is operating properly it should read approximately 14 volts. If the gauge reads below 13 volts, the alternator is not charging the battery and the system should be checked by a qualified technician.

Oil Pressure Gauge:

Confirms and indicates the presence and pressure of engine oil. If the gauge reads low, it should be checked by a qualified technician.

Engine Temperature:

Indicates the engine coolant temperature. If the gauge reads over 240 degrees the unit should be checked by a qualified technician.

Hour Meter:

Indicates the accumulated hours of the engine. This should be used to schedule maintenance.

Pre-Operating Section

2.2 SAFE OPERATIONS:

WARNING

ALL personnel using, maintaining or servicing this unit must be trained in all safety procedures outlined in this manual. Improper or careless use of this equipment CAN result in personal injury or death.

Operations shall be restricted to:

1. Properly trained, qualified and experienced operators and/or qualified and experienced maintenance and test personnel.
2. Trainees under the direct supervision of qualified and experience personnel.
3. Qualified and experienced maintenance and service personnel.

Operators who qualify to operate this equipment under the above restrictions shall also comply with the following physical requirements:

1. Have good vision and the ability to read and understand this manual as well as all safety and operational decals on the equipment.
2. Be capable of hearing, with or without a hearing aid, at a level needed to safely operate this equipment.
3. A record of mental stability with no history of epileptic seizures, dizziness, or any other disability that may result in injury to himself or others.

If any of these requirements are not satisfied at any time, the person failing to meet these requirements **MUST NOT OPERATE THIS EQUIPMENT.**

Pre-Operating Section

2.2 SAFE OPERATIONS (continued):

Additional Requirements:

1. Each operator must demonstrate competence to understand all safety decals, operator's manuals, safety codes, applicable government regulations, and all other information applicable to the safe and proper operation of the leaf vacuum.
2. Each operator must demonstrate the ability to recognize an emergency situation that may arise during vacuuming operations and the knowledge and procedures to implement corrective action.
3. Each operator must demonstrate or provide evidence of qualification and experience prior to operating the leaf vacuum.
4. Each operator must be able to recognize existing or potential problems regarding the mechanical integrity of the leaf vacuum and report any maintenance requirements to the supervisor in charge.
5. Each operator must wear the proper personal clothing and safety gear. (Refer to SAFETY PRECAUTIONS Section 5.4)
6. Operators must not be physically or mentally fatigued.
7. Operators must not be under the direct or indirect influence of alcohol and/or drugs. This includes prescription drugs that could cause drowsiness, dizziness, or any other condition that would impair their ability to operate or use this equipment in a safe manner.

Pre-Operating Section

2.3 PREPARATION FOR OPERATION

CAUTION

Before your leaf vacuum is put into operation it is very important to read and follow the procedures outlined in the engine owner's manual. (EOM).

For specific information regarding the following checks please refer to the "Maintenance" section of this manual and the engine owner's manual.

WARNING

DISENGAGE the clutch and remove the negative battery cable before performing the following checks.

WARNING

NEVER place any part of the body under or behind guards or any other area in which you cannot see.

IMPORTANT CHECKS:

NOTE: The following checks contained in the next three sections should be performed prior to leaving the storage area.

1. Check engine fuel, coolant and oil levels. (see EOM)
2. Check engine air filter
3. Check all bolts and nuts to ensure they are tight.
4. Check all controls for free and proper operation.
5. Check main drive belt (if equipped) for proper adjustment.
6. Inspect the fan blades to ensure that they are not bent , deformed, fatigued or cracked.
7. Inspect the intake hose flange to make sure it is connected correctly to the blower housing.
8. Inspect the leaf vacuum frame and structure for any bent, broken, cracked, missing or loose parts.
9. Check all guards to ensure they are undamaged, in place and properly secured.
10. All decals must be in place and legible prior to operating the leaf vacuum. See the decal section for decal replacement.

Pre-Operating Section

2.4 PRE-TRANSPORT CHECKS

WARNING

Failure to properly hitch the leaf vacuum to the tow vehicle, verify the road worthiness of the leaf vacuum and the tow vehicle and verify all equipment is properly stowed, may cause serious injury or death to yourself or others.

TOW VEHICLE MUST have proper towing capacity for the leaf vacuum being towed. Check the tow vehicles operating manual for rated capacity.

Do not tow the leaf vacuum unless all important checks listed below are completed.

IMPORTANT CHECKS:

1. Hitch is properly secured to tow vehicle and hose boom secured.
 - a. Frame must be level or the tongue slightly lower than the rear of the leaf vacuum while towing to ensure proper weight distribution. The hitch may have to be adjusted when towing with vehicles of varying tow hitch height.
2. Safety chains installed correctly.
 - a. Chains routed under trailer tongue in an "X" pattern between tow vehicle and trailer.
 - b. Slack in chain should be adjusted to permit turning but should not be dragging on the ground.
3. Connect trailer wiring to the tow vehicle and ensure that all trailer lighting is operating properly.
4. Ensure that the safety breakaway switch is functioning properly and attached securely to the tow vehicle. Allow enough slack to ensure that vehicle turns will not activate the safety breakaway switch.

NOTE: Follow manufacturers procedure to ensure tow vehicles brake control box is properly adjusted.
5. Check the general condition of the tires, tire pressure and ensure that all lugnuts are securely fastened.

Pre-Operation Section

2.4 PRE-TRANSPORT CHECKS (continued):

IMPORTANT CHECKS (continued):

6. Visual examination of the leaf vacuum frame, suspension and structure to determine if all components are correctly positioned and secured for travel.
7. Check the intake hose boom to verify that it is securely fastened to the leaf vacuum and can not swing free.
8. Verify there are no loose tools or materials on the trailer, inside the intake and exhaust hoses, or inside the engine sheet metal.
9. Check all cones, wheel-chocks, signs or other support tools and materials to ensure proper stowage.
10. Verify the driver of the tow vehicle is qualified to tow the type and weight of the unit.

Pre-Operating Section

2.5 PERSONAL PROTECTIVE EQUIPMENT AND CLOTHING

IMPORTANT CHECKS:

Anyone operating ODB's leaf vacuums **MUST** wear appropriate protective equipment and clothing to protect them from injury during operations.

WARNING

Always wear proper safety equipment as outlined below, not wearing such equipment CAN result in serious personal injury or possible death.

PROTECTIVE EQUIPMENT:

1. **Head Protection:** Hard hats without under-chin strapping.
2. **Eye Protection:** Wraparound goggle type eye protection held in place with an elastic band around the head or a hard hat mounted face shield, which provides full protection of the face. Eye protection must meet ANSI Z87.1 standards.
3. **Hearing Protection:** plug type or "muff type" ear protection should be worn at all times while operating the unit.
4. **Breathing Protection:** Paper filter type dust masks should be worn to protect from dirt and dust particles during the vacuuming process.
5. **Reflective Vests:** Highly visible vests should be worn so motorists can see the operator in all weather and lighting conditions.
6. **Work Gloves:** Gloves should be worn to protect the hands and wrists from debris.
7. **Steel Toed Boots:** should be worn to protect the feet.

DANGER

Work clothes MUST be close fitting, but not restrictive of movement, without any loose parts that could be entangled in any parts of the leaf vacuum. This includes items such as jewelry, chains and backpacks.

Pre-Operating Section

2.6 WORK SITE PREPARATION

WARNING

Never place any part of the body under or behind guards or any other visually obscured area.

Making sure the leaves are clear of possible dangerous material is critical to safe vacuuming. Vacuuming up metal, glass, rocks or other dangerous material CAN cause serious damage to the equipment or personal injury.

The following guidelines must be followed to insure safety.

1. An inspection of the leaves to be vacuumed must be done prior to the vacuuming process. We realize that it is impossible to completely inspect every inch of leaves being vacuumed, but it is imperative that all leaves be inspected for obvious dangerous material before vacuuming.
2. The operator should never be in the line of traffic, the operator should work on the shoulder whenever possible.
3. The operators should place cones or other barriers to provide adequate warnings to vehicles and pedestrians that vacuuming is in progress.
4. Strobe lights on the leaf vacuum and on the tow vehicle should be on at all times for high visibility.
5. Confirm that all operators are wearing proper clothes and personal protective equipment.
6. Restrict all personnel, except the operator from the area near the leaf vacuum. **DO NOT** allow pedestrians, children or animals near the work area.
7. Make sure that the exhaust hose fits properly into the box container so that all debris is blown into the box container.

3.0 OPERATING SECTION

 **WARNING**

Read and understand this entire manual before operating, maintaining or repairing the leaf vacuum.

3.0 OPERATING SECTION

- 3.1 Starting Engine
- 3.2 Engaging PTO
- 3.3 Vacuuming Leaves

Operating Section

figure 3a
(Typical)

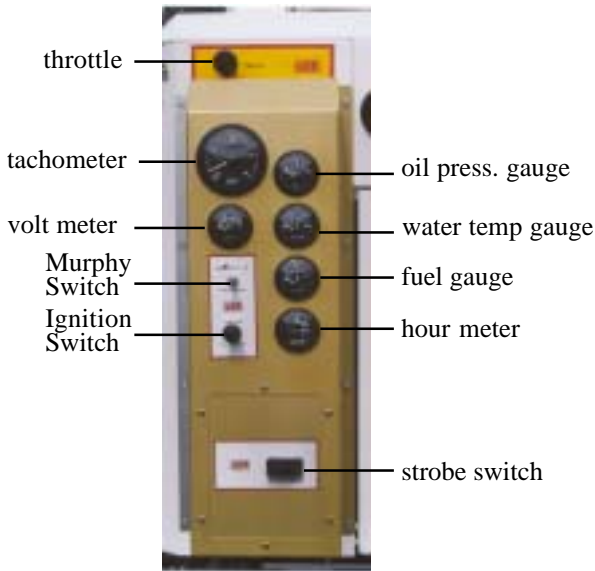

figure 3b



PTO shown disengaged

3.1 Starting Engine

CAUTION

Always make sure the PTO is disengaged before starting unit. (See figure 3b)

WARNING

Thoroughly read and understand the safety and pre-operating sections of this manual before starting the engine.

CAUTION

DO NOT start the engine in an enclosed building. Proper ventilation is required before starting the engine.

Review the Engine Operating Manual supplied with your leaf vacuum for specific start-up, maintenance and operating instructions. It is especially important to review break-in service procedures for brand new units.

Starting Procedure (refer to figures 3a and 3b):

1. Perform all the pre-starting, pre-operating checks outlined in the EOM and in this manual.
2. Make sure the PTO is disengaged as shown in figure 3b.
3. Turn the throttle control (fig. 3a) counter-clockwise 2 revolutions.
4. Depress and hold the Murphy switch while starting.

Operating Section

figure 3a

(Typical)

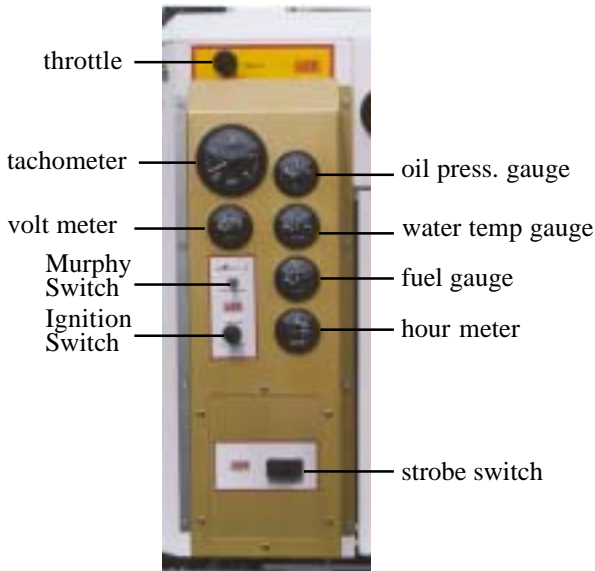

3.1 Starting Engine, continued;

IMPORTANT: Do not operate the starter for more than 30 seconds at a time. To do so may overheat the starter. If the engine does not start the first time, wait at least 2 minutes before trying again. If the engine fails to start after 4 attempts, see the trouble shooting section of the EOM and this manual.

5. Pull the ignition switch all the way out, when the engine starts release the ignition switch. It should spring back to the first position.

IMPORTANT: If the ignition switch is released before the engine starts, wait until the starter and the engine stop turning before trying again. This will prevent possible damage to the starter and/or flywheel.

6. After the engine starts, continue to hold the Murphy Switch in until the oil pressure gauge reads at least 15 psi. The Murphy shut off switch will not allow the engine to operate below this level. If the gauge does not rise above 15 psi within 5 seconds, stop the engine and determine the cause. Normal operating oil pressure is 50 psi with oil at normal operating temperature.
7. Check all gauges for normal engine operation. If operation is not normal, stop the engine and determine the cause.

IMPORTANT: To assure proper lubrication, operate the engine at or below 1200 rpm with no load for 1 -2 minutes. Extend this period 2 - 4 minutes when operating at temperatures below freezing.

8. Watch the coolant temperature gauge. Do not place engine under load until it is properly warmed up. The normal engine coolant temperature range is 180 - 202 degrees F.

Operating Section

3.2 Engaging the PTO

figure 3b

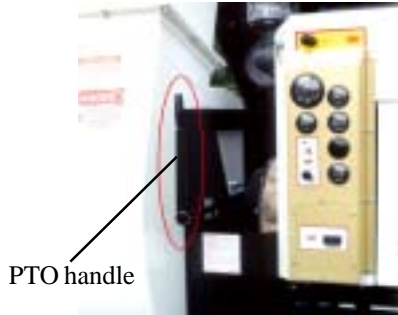

PTO shown disengaged

figure 3c



safety assist cylinder

⚠ WARNING

Thoroughly read and understand the safety and pre-operating sections of this manual before starting the engine.

⚠ WARNING

Make sure the intake hose is properly attached and make sure the front of the hose is clear of any objects which could be inadvertently vacuumed during the PTO engagement process.

Review the Engine Operating Manual supplied with your leaf vacuum for specific start-up, maintenance and operating instructions. It is especially important to review break-in service procedures for brand new units.

Engaging the PTO (refer to figures 3b and 3c):

1. Perform all the pre-starting, pre-operating checks outlined in the EOM and in this manual.
2. Start the engine as previously discussed in this manual and in the EOM.
3. Once the engine has been allowed to thoroughly warm up (engine temperature gauge should read at least 180 degrees) pull the throttle control until the engine reaches 1000 rpm.
4. Grasp the PTO handle (fig. 3b) and slowly push the handle forward. **NOTE:** Most of ODB's units have a PTO assist cylinder which engages the PTO at a specific speed in order to properly engage the PTO. Because of this the PTO handle only needs to be raised slightly, then the assist cylinder will take over and engage the PTO automatically. (fig. 3c)

Operating Section

3.2 Engaging the PTO, continued;

figure 3b

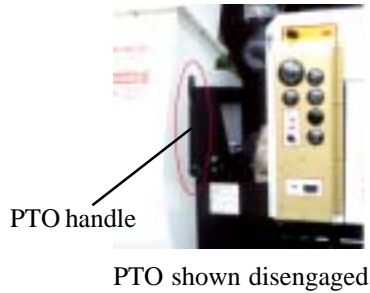

IMPORTANT: If the unit experiences any heavy vibrations or makes any unusual noises, shut the engine down and after following the necessary safety guidelines, have a qualified technician investigate the cause. **DO NOT** operate a unit that is in a state of disrepair.

5. If the unit is running smoothly and does not display any excessive vibration, the unit is ready to vacuum leaves. **NOTE:** Please see the next section before vacuuming leaves.

The unit is fully engaged when the PTO handle is pointing to the right. It is fully disengaged when the handle is pointing straight up.

Disengaging the PTO (refer to figures 3b and 3d):

1. Decrease the rpm to 1000 rpm.
2. Grasp the PTO handle and slowly disengage the PTO.
3. When the PTO is fully disengaged, the engine can be shut down.

Operating Section

3.3 Vacuuming Leaves

WARNING

Thoroughly read and understand the safety, pre-operating and operating sections of this manual before vacuuming. Wear the proper safety equipment as outlined in this manual.

WARNING

Make sure the exhaust hose is connected to the box container properly before vacuuming leaves. Visually inspect the leaves before vacuuming for any material that could be harmful to the leaf vacuum or people. This includes bottles, wood, steel, glass, stone or other hard or breakable objects.

Vacuuming Leaves:

1. Start the engine and engage the PTO using the procedures stated earlier in this manual.
2. Set the engine throttle to around 1200 rpm.

NOTE: Always vacuum leaves using the lowest rpm as possible. This saves fuel and decreases the amount of dust escaping the box container.

3. Lower the intake hose to a few inches above the leaf pile. Hold the intake nozzle at a 45 degree angle to allow proper air flow. This should allow the leaves to be vacuumed. **DO NOT** bury the intake nozzle into the leaf pile, this will cut off the air flow and will make vacuuming much more difficult and increase the chance of clogging.
4. If the leaves are not vacuuming, increase the rpm to 1400 and try vacuuming at this setting.

NOTE: Wet leaves will need higher rpm's to vacuum whereas dry leaves will only need minimal rpm's.

5. Continue moving the nozzle in a sweeping motion above the leaves while vacuuming.

4.0 MAINTENANCE SECTION

WARNING

Read and understand this entire manual before operating, maintaining or repairing the leaf vacuum.

4.0 MAINTENANCE SECTION

- 4.1 Maintenance Overview
- 4.2 Maintenance Interval Chart
- 4.3 Lubrication
- 4.4 Preventative Maintenance
- 4.5 Torque Values
- 4.6 Quick Reference Maintenance Chart

4.0
MAINTENANCE
SECTION

Maintenance Section

4.1 MAINTENANCE OVERVIEW:

CAUTION

Only properly trained personnel should perform maintenance or repair on this equipment. Consult ODB before performing any maintenance procedures that is not specifically covered in this manual. Improper maintenance or repair may void any and all warranties on this equipment.

WARNING

Improper maintenance or repair CAN result in equipment damage and/or personal injuries.

DANGER

BEFORE CONTINUING, please read and understand the Safety, Pre-operating and Operating sections of this manual before doing any procedures in this section.

A properly maintained leaf vacuum will dramatically extend the life of the unit and will create a safer work place as well. For the general safety and welfare of all personnel it is important to create a scheduled maintenance program that covers all the elements in this manual as well as the engine, PTO and axle owner's manuals provided with this unit.

Use the chart on the following page as a guide for your scheduled maintenance program. If there are any questions concerning any of these procedures please call ODB.

Maintenance Section

4.2 MAINTENANCE AND LUBRICATION CHART

This chart is only a reference, always consult the Owners Manual of the Engine, PTO, etc for actual recommendations
(Use Hour Meter as a Guide)

Item	Daily/ 10 hrs	40 Hours/ Week	80 Hours/ 2 Weeks
Check Engine Oil Level	●		
Check Coolant Level	●		
Check Fuel Filter Sediment Bowl	●		
Lubricate Main Shaft Bearings (about 2 oz.)	●		
Lubricate PTO Bearings	●		
Check Air Intake Filter	●		
Check/Clean Pre-Filter	●		
Check Lug Nuts and Tire Pressure/Condition	●		
Inspect Radiator for leaks and trash Buildup. Clean radiator screen	●		
Check Engine as Described in the Engine Owner's Manual	●		
Inspect Exterior of Blower Housing for Damage	●		
Check Trailer Brake Lights and Turn Signals	●		
Check Power Band For Proper Alignment, Wear, and Tightness (if equipped)	●		
Inspect Impeller For Damage	●		
Check All Nuts and Bolts For Tightness	●		
Check Tow Bar For Damage or Wear	●		
Check Bolt Hole Where the Tongue and Trailer Bed are Connected For Wear		●	
Clean and Check Battery and Connections		●	
Inspect Intake and Exhaust Hoses		●	
Inspect All Ducts for Damage		●	
Remove Blower Housing Face and Inspect Liners inside Blower Housing for Wear		●	
Grease/Inspect Wheel Bearings for Corrosion or Wear			●
Inspect All Hydraulic and Fuel Lines for Leaks or Wear			●

Maintenance Section

4.3 LUBRICATION:

CAUTION

Remove the negative battery terminal before attempting any lubrication procedures.

Figure 4.3A

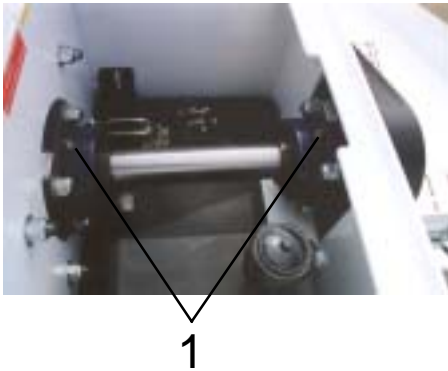

WARNING

Thoroughly read and understand the safety and pre-operating sections of this manual before performing any lubrication procedures.

The following are general lubrication procedures for our standard units. Any special or custom built units may have other lubrication procedures not directly mentioned in this manual. Please consult ODB before any lubricating procedures not specifically mentioned in this manual.

Proper lubrication of your unit correlates directly to how long your unit will last. A properly maintained unit will last much longer than a unit that is not maintained properly. **NOTE:** Always lubricate bearings at the end of each work day. This will displace any moisture in the bearings. Also lubricate thoroughly before extended shutdown or storage.

Lubrication Points:

1. **Drive Bearings (figure 4.3a):** These bearings are critical components of the belt-driven units. These bearings should be greased every 10 hours with approximately two strokes from the average hand pump grease gun. The type of grease used in these bearings are also critical to the performance of the bearings. A multi-purpose, heavy-load, high-temperature, moisture resistant #2 grease is required for the drive bearings. ODB recommends LubeMaster Premalube 4234 grease. Other premium quality grease that matches the above requirements may be used but after years of testing ODB recommends the Premalube grease.

NOTE; DO NOT mix different types of grease. The old grease **MUST BE** purged before a different type of grease is used. Mixing grease **WILL** cause premature failure to the bearings.

Maintenance Section

4.3 LUBRICATION, continued;

Lubrication Points, continued;

2. **Trailer Wheel Bearings (figure 4.3b):** Most of ODB's units are equipped with "EZ-Lube" grease fittings. This allows the operator to grease the bearings without removing the hubs. The "EZ-Lube" feature consists of axle spindles that have been specially drilled and fitted with a grease zerk in their ends (fig. 4.3c). When grease is pumped into the zerk, it is channelled to the inner bearing and then flows back to the outer bearing and eventually back out the grease cap hole. The trailer wheel bearings should be checked and greased after the first 30 days of service then at the beginning of every season.

Figure 4.3b



Grease fitting is behind rubber plug

Figure 4.3c

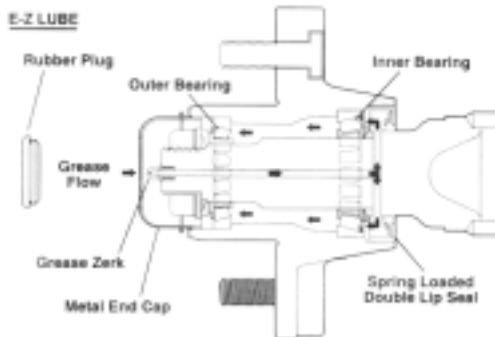

Grease specifications:

Thickener Point.....Lithium Complex
Dropping Point.....230 degr. C minimum
Consistency.....NLGI No.2
Additives.....EP,Corrosion & Oxidation
Inhibitors
Base Oil.....Solvent refined Petroleum Oil
Base Oil Viscosity.....@40 deg. C 150cSt Min.
Viscosity Index.....80 Minimum
Pour Point.....-10 deg. Minimum

Approved Sources:

Mobil Oil.....Mobilgrease HP
Exxon/Standard.....Ronex MP
Kendall Refining.....Kendall L-427
Ashland Oil Co.....Valvoline Val-plex EP Grease.
Penzoil.....Premium Wheel Bearing Grease 707L

For any questions concerning wheel lubrication please consult the axle owner's manual supplied with your leaf collector or contact ODB.

Maintenance Section

Figure 4.3d



One fitting on each bearing

PTO bearing
PTO shaft grease fitting
Figure 4.3e

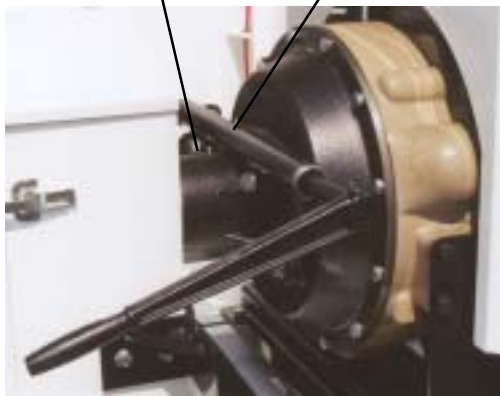

Figure 4.3f



4.3 LUBRICATION, continued;

Lubrication Points, continued;

3. **Boom Swivel Bearings (figure 4.3d):** These bearings are on most of ODB's model LCT600 and LCT6000 after 1996. Grease the boom bearings once every week with a multi-purpose moisture resistant #2 grease.
4. **PTO Bearing & PTO Shaft Fitting (figure 4.3e):** The PTO bearings should be greased after every 50 hours of operation with a high grade, high temperature lithium base #2 lubricant having an operating temperature of 200 degrees F. Three to five pumps with a hand operated grease gun is sufficient. **NOTE:** Units manufactured after 2000 may not have a PTO bearing grease fitting. These bearings are sealed and do not require greasing.

The PTO crossover shaft and linkage should be lubricated with high temperature lithium base #2 lubricant after 200 hours of operation.

5. **Hinge and Friction Points:** Leaf vacuum operation and longevity can be improved by keeping hinges and friction points lubricated. ODB recommends that lubrication be performed weekly. Use SAE30 weight oil on hinges and a premium grade, high temperature lithium based EP#2 grease on friction points.
6. **Hitch and Tongue (figure 4.3f):** The hitch and hitch ring should be checked and lubricated daily to minimize wear. Apply grease and/or SAE30 weight oil wherever applicable.

Maintenance Section

4.4 PREVENTATIVE MAINTENANCE

CAUTION

Remove the negative battery terminal before attempting any maintenance procedures.

WARNING

Thoroughly read and understand the safety and pre-operating sections of this manual before performing any maintenance procedures.

The following are general preventative maintenance procedures for our standard units. Any special or custom built units may have other preventative maintenance procedures not directly mentioned in this manual. Please consult ODB before doing any preventative maintenance procedures not specifically mentioned in this manual.

Proper preventative maintenance of your unit, just like lubrication, correlates directly to how long your unit will last. A properly maintained unit will last much longer than a unit that is not maintained properly.

Preventative Maintenance:

1. **Engine Oil:** Change the oil and oil filter according to schedules provided in your engine's owner's manual (EOM). The engine oil level should be checked every day. The level should be checked after the engine has been stopped for a period of time. This will allow the oil to drain back into the oil pan, allowing a better indication of the true oil level. If the level is low, see the engine's owner's manual for the correct type of oil.
2. **Engine Coolant:** Check the coolant level before starting the unit each day. The coolant level should not be less than one inch below the top of the radiator.

CAUTION

NEVER check the engine coolant when the engine is hot. Allow the engine to cool at least one hour before checking the coolant. Check the engine owner's manual for instructions. **ALWAYS** wear eye and hand protection when working with the radiator.

Maintenance Section

4.4 PREVENTATIVE MAINTENANCE, continued;

Preventative Maintenance, continued;

- Engine Radiator:** The engine radiator on a leaf vacuum becomes clogged with dust and debris frequently because of the nature of the job. If the radiator is not cleaned properly it WILL cause improper cooling and WILL eventually cause serious damage to your engine. The debris accumulating on the radiator can be lessened by lowering the RPM on the engine to a level just enough to vacuum the leaves. The higher the RPM the more dust that is put into the air. Also, it may be necessary to put mesh or tarps on the top of the leaf box container to reduce the debris and dust. If this is done, make sure there is enough air ventilation on the box so the box is not blown apart. Proper belt condition and coolant mix-ratio, as well as coolant conditioners, are all critical to proper engine cooling. See the engine owner's manual for specifics on coolant mixture ratios and conditioners. The radiator should be inspected and cleaned with compressed air every day at the very least.

DANGER

NEVER attempt to clean or inspect the radiator with the engine running or while the engine is HOT. Allow the engine to cool at least one hour before maintaining the radiator. Check the engine owner's manual for instructions. ALWAYS wear eye and hand protection when working with the radiator.

- Engine Air Cleaner:** Due to the large amounts of dust generated in collection leaves, it is critical to your engine's life that the pre-cleaner and air filter be maintained properly. The pre-cleaner should be cleaned at least daily of any debris that has accumulated. If conditions warrant it should be cleaned more. The air filter should be checked daily and should be replaced at the first sign of it being dirty. DO NOT attempt to clean the air filter, replace the dirty air filter. It is a good idea to clean out the air filter housing once a week to clean any dust debris that may have accumulated.
- Tires and Wheels:** Tires and wheel lug nuts should be checked on a daily basis. Tires should be checked for excessive wear and proper air pressure. Check the side wall of the tire for proper inflation pressure. Torque all 1/2" diameter lug nuts from 90 to 120 foot pounds. Torque all 5/8" diameter lug nuts from 175 to 225 foot pounds. Consult the axle manufacturer's owner's manual for more detailed information.

Maintenance Section

4.4 PREVENTATIVE MAINTENANCE, continued;

Preventative Maintenance, continued;

- Trailer Brakes (if equipped):** Most of the newer ODB leaf vacuums have electric brakes on the axle(s). It is critical that these brakes work properly. The trailer's brakes should be checked daily, before leaving the equipment yard, for proper operation. The trailer brakes are designed to work in synchronization with your tow vehicles brakes. Never use your tow vehicle or trailer brakes alone to stop the combined load. The synchronization between the tow vehicle and the leaf vacuum is accomplished through the brake controller and needs to be set correctly. Please read the brake controllers manual and the axle owner's manual for these procedures.



DO NOT tow the leaf vacuum with damaged or non-operating brakes. Check the brakes daily for proper operation.

The brakes should be adjusted after the first 200 miles of operation when the brake shoes and drums have "seated" and at 3,000 mile intervals, or as use and performance requires. The adjustment procedures are beyond the scope of this manual, please see the axle owners/service manual for specific instructions.

The trailer brakes should be inspected and serviced at yearly intervals or more often as use and performance requires. Magnets and shoes must be changed when they become worn or scored thereby preventing adequate vehicle braking. Again, see the axle owner's/service manual for specific procedures.

- FUEL TANK:** Fill the fuel tank at the beginning of the work shift leaving a gap of at the top of the tank for expansion of fuel. A full fuel tank will reduce the possibility of condensation forming in the tank and moisture entering the fuel lines. Check the fuel lines daily for cracks, holes or tightness.

Maintenance Section

4.4 PREVENTATIVE MAINTENANCE, continued;

Preventative Maintenance, continued;

CAUTION

ALWAYS wear eye and hand protection when working with the battery.

8. **BATTERY:** ODB's units are supplied with "maintenance free" batteries so there is no need to check fluid levels but the battery terminals should be checked daily for corrosion. Remove any corrosion with a wire brush and coat the terminals with light grease or petroleum jelly to reduce the possibility of corrosion. Also check the battery cable for wear all cable connections and battery tie downs to be certain that they are not loose.
9. **DRIVE BELT (if equipped):** The main drive belt should be checked daily for cracks and for proper tension. If the belt shows any sign of

CAUTION



Remove the negative battery cable before opening the belt guard.

cracking it should be replaced immediately. The proper tension of the belt should be approximately 1/2" deflection when applying a 8 pound pull.

10. **FASTENERS:** Fasteners should be checked weekly for the first 30 days and monthly thereafter. They must be in place at all times and properly torqued. For general torque values see the torque chart at the end of this section.
11. **INSTRUMENT PANEL AND CIRCUIT BOARD:** The instrument panel and circuit board should be cleaned with compressed air daily. Also the circuit board connectors should be wiped clean and have nonconductive grease applied weekly to help maintain solid connections.
12. **BOOM HYDRAULIC PUMP:** Check the fluid level daily. If fluid needs to be added, automatic transmission fluid (ATF) is recommended. Clean debris and oil off the solenoid and pump daily. A build up of debris can cause premature failure to the pump. Check and tighten all hydraulic fittings making sure there are no leaks.

Maintenance Section

4.5 TORQUE VALUES

RECOMMENDED TORQUE IN FOOT POUNDS		
TYPE	HEX HEAD CAP SCREWS	
SAE GRADE	5	8
HEAD MARK		
SIZE		
1/4"	9	9
5/16"	18	18
3/8"	33	33
7/16"	52	52
1/2"	80	80
9/16"	115	115
5/8"	160	160
3/4"	280	280
7/8"	450	450
1"	675	675

DO NOT use these values if a different torque value or tightening procedure is given for a specific application. Torque values listed are for general use only. Check tightness of fasteners periodically.

Make sure fastener threads are clean and that you properly start thread engagement. This will prevent them from failing when tightening.

Maintenance Section

4.6 QUICK REFERENCE MAINTENANCE CHART:

CAUTION

Only properly trained personnel should perform maintenance or repair on this equipment. Consult ODB before performing any maintenance procedures that is not specifically covered in this manual. Improper maintenance or repair may void any and all warranties on this equipment.

NOTE: THIS CHART IS FOR REFERENCE ONLY, CONSULT THE ENGINE'S OWNERS MANUAL FOR SPECIFIC DETAILS. FOR JOHN DEERE 4045D ENGINES ONLY.

ITEM	
Fuel Requirement	Diesel fuel specified to EN 590 or ASTM D975
Fuel Capacity	30 gallons
Low / High Idle Speed	750 rpm / 2,600 rpm
Engine Oil: Grade Viscosity Capacity	API service classification; CG-4, CF-4 SAE15W-40 / SAE10W-40, or SAE 5W-30 (see EOM manual for details) 9 US qt
Coolant: Type Mixture Freezing Point Amount	Permanent type of antifreeze; green in color (see EOM manual) Water 50%; Antifreeze 50%; (1:1) -35 degrees C (-31 degrees F) 2.5 US gallons
Hoist Hydraulic Tank Type Amount	High Viscosity, Premium Hydraulic Fluid; Shell Tellus #68 recommended. (ISO 68 viscosity grade) 8 US gallons

WARNING

Improper maintenance or repair CAN result in equipment damage and/or personal injuries.

DANGER

BEFORE CONTINUING, please read and understand the Safety, Pre-operating and Operating sections of this manual before doing any procedures in this section.



SERVICE SECTION

SERVICE SECTION

Service and Troubleshooting
Wiring Diagrams

ODB COMPANY

5118 Glen Alden Drive
Richmond, VA 23231

800-446-9823



SERVICE AND TROUBLE SHOOTING

SERVICE AND TROUBLESHOOTING

- *Service and Repair
- *Engine Electrical Troubleshooting
- *Circuit Board Troubleshooting
- *Auto PTO Adjustment Guide
- *Hydraulic Boom Troubleshooting
- *Impeller Installation
- *Belt Adjustment and Replacement Guide
- *Bearing Installation Guide
- *Liner Replacement / Installation

ODB COMPANY

5118 Glen Alden Drive
Richmond, VA 23231

800-446-9823

SERVICE AND REPAIR SECTION

LUBRICATION:

We recommend that you check the fluid levels and lubricate your machine daily. If you create a schedule of daily maintenance you can avoid a lot of costly down time later in the machine's life.

Start by checking the engine fluid levels. It may be wise to consult your engine owner's manual for other recommendations concerning regular maintenance and specific intervals.

Next lubricate the power take off as recommended in the PTO owner's manual. Stein PTO anti-friction bearings should be lubricated every 20 hours of operation with a short fiber, high grade, high temperature lithium #2 lubricant having an operating temperature of 200 degrees F. Three to five pumps with a hand operated grease gun is sufficient. **DO NOT MIX SODIUM OR CALCIUM BASE GREASE WITH LITHIUM GREASE.** Levers and linkage should be lubricated with engine oil every 50 hours.

The impeller shaft bearings should be lubricated every 8 to 10 hours of operation. We have experimented with various lubricants and have found the ALMAGARD 3751 lubricant offered by Lubrication Engineers to be a superior product. You can obtain this from us or you can contact Lubrication Engineers for a dealer in your area. More information on them is located in the back of this manual. Other suitable lubricants include Amoco Rycon No.2 and Mobil's Mobilgrease 532. **DO NOT OVERLUBRICATE** the bearings. Approximately 2 strokes with the average automotive grease gun is sufficient each time the bearing is lubricated.

AIR FILTER:

Air filter service requirements will vary with the conditions under which your machine operates most often. In dusty weather the filter will need to be checked more often than in damp rainy weather. Air filters should be serviced by **REPLACEMENT ONLY.**

Two stage elements may need the primary element cleaned as often as twice daily, where the secondary element will only need to be checked daily. Filters that become too dirty can cause poor fuel economy and a considerable loss of power.

BLOWER HOUSING:

Daily cleaning of the blower housing through the clean out door is recommended to remove any small heavy objects that may become trapped in the bottom of the housing. **BEFORE** opening the inspection door disconnect a battery cable. A limit safety switch is located on the clean out door but we recommend disconnecting a battery cable before opening the door. After cleaning the housing, take time to visually inspect the impeller and blower housing liners for excessive wear or cracking. This only takes a moment but could save extensive down time later.

At the end of every week we recommend that you remove the blower housing face and carefully inspect the impeller and blower housing liners to insure that there is no damage. Operating a unit with a damaged impeller, liner, or blower housing can cause tremendous damage to the machine and may cause severe injury.

TRAILER:

The trailer should only require yearly maintenance such as wheel bearing lubrication and lubrication of the parking jack. The wheel bolts should be checked for tightness **EVERY** time the leaf collector is used. They should be torqued to 95 ft. lbs.

The lights on the trailer should be checked daily by the driver to insure their proper operation.

SERVICE AND REPAIR SECTION

PAGE 2

Periodic cleaning of the battery box and the hydraulic power pack is recommended to help insure reliable operation of the pump and to increase battery life. More information on the hydraulic unit is located in the back of the manual.

The parking jack that is supplied with the leaf vacuum is adequate for support of the unit. Periodic lubrication of the jack is needed.

PTO:

Some power take offs do not require adjustment. These units use a clutch similar to a car or light truck. Others use an over center engagement that requires more frequent adjustment. To determine the requirements of your particular unit we suggest that you consult the manual for your PTO that was supplied with your machine.

BELT ADJUSTMENTS (For Belt Drive Units Only):

The type of V belt arrangement supplied with the leaf vacuum is called a power band. Its one piece construction makes it stronger than multiple belts but its service requirements are very similar. Periodically check the band for cracks or signs of extreme wear. If the band should become loose, it can easily be adjusted using the following method:

- 1) Turn the engine off and remove a battery cable
- 2) Loosen the 4 bolts that fasten the engine to the adjustable motor mounts.
- 3) Turn the adjusting bolt closest to the band clockwise until the band becomes tight.
- 4) Using a straight edge to check the alignment across the face of the pulleys, turn the other adjusting bolt clockwise until the pulleys are back in line.
- 5) You will notice that as you tighten the second adjuster the band becomes loose again. Repeat steps 3 and 4 until the band has about 1/4" of movement either way in the center of the pulley. It is important to keep the pulleys in line. If they are not, band life will be considerably shortened and vibration may occur.
- 6) When the band is properly adjusted, tighten the engine mounting bolts and replace all guards.

Hydraulic Hose Boom:

Check the fluid level in the hydraulic pump reservoir every day. If fluid needs to be added be sure to use Dextron II hydraulic fluid. If the boom travels too fast or too slow adjust the fluid by using the brass fluid control valve located near the pump. Be sure to keep the pump clean of debris and check the wiring contacts regularly.

Engine Electrical Troubleshooting Guide

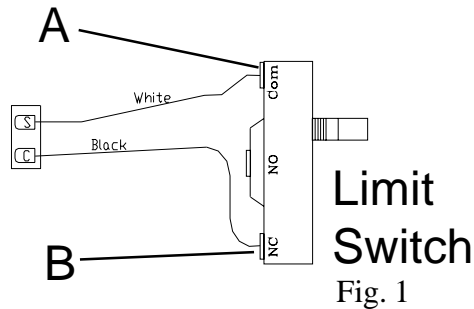

ENGINE RUNS ONLY WHEN OVERRIDE BUTTON IS DEPRESSED

1. Make sure the PTO is disengaged.
2. Take a look at the limit switch located at the inspection door of the blower housing. Check to be sure that the inspection door closes completely and that the door presses in the limit switch. The limit switch is extremely sensitive and only needs to open 1/64" to shut the engine off.
3. If the inspection door closes properly and presses in the limit switch properly, then disconnect the two wires from the back of the limit switch.
4. Start the engine using the normal procedure then release the shut off button. If the engines continues to run then the problem lies in the limit switch or the limit switch wiring. If the engine still cuts off then the limit switch is not the cause, go to Testing the shut off switch.

TO TEST THE LIMIT SWITCH:

5. With an ohm meter check the resistance of the terminals A & B (Fig. 1) while the button is not depressed. There should be no resistance or continuity. With the button depressed there should be full continuity or infinite resistance, if not the switch is bad and should be replaced.

TESTING THE SHUT OFF (MURPHY) SWITCH:

6. Pull out the ignition switch to the first position.
7. Put a test light to terminal B (Fig. 3) to test for current. If there is no current at B, power is not getting to the shut off switch. Then the problem is not the shut off switch. If there is current at terminal B, put a test light on the fuse at location Z (Fig. 3) above. If there is no current there the fuse is blown. Replace fuse. If there is current at B and Z, push the override button (letter X above, Fig. 3) in on the shut off switch. While the button is depressed place the test light on terminal C (Fig. 3). If there is current at terminal C then the shut off switch is functioning properly and the problem lies elsewhere. If there is no current at terminal C then the shut off switch is defective and needs to be replaced.
8. Next locate the fuel solenoid valve located on the fuel injector pump (Letter C, Fig. 2). It has an orange wire running to it. Pull the ignition switch to the first position. Put a test light on the terminal of the fuel solenoid where the wire is attached. Test light should light up showing current, if not shut off switch is bad. Replace.
9. If engine still cuts off after shut off button is released then test the water temperature switch (located on the engine block, Letter D, fig. 2) by removing the brown wire attached to the temperature switch. Start the engine using the normal procedure then release the shut off button. If the engine continues to run then the water temperature switch is defective. Replace the switch. If the engine shuts off, do the same test on the oil pressure switch. If the engine continues to shut off after this test call ODB for additional service procedures.

Typical Wiring Diagram

Fig. 2

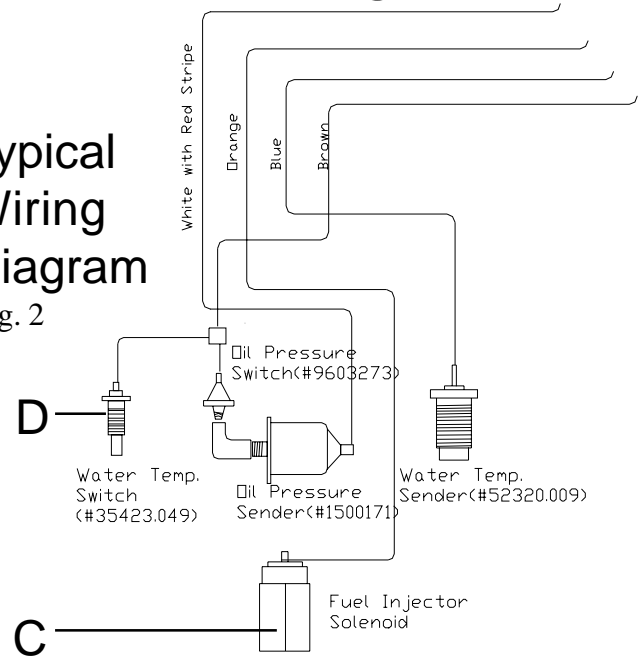

Murphy Switch

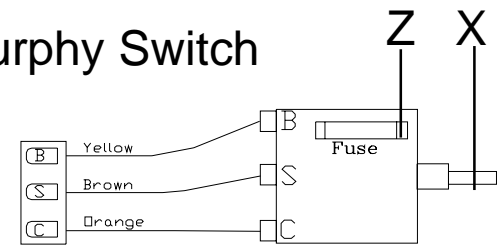
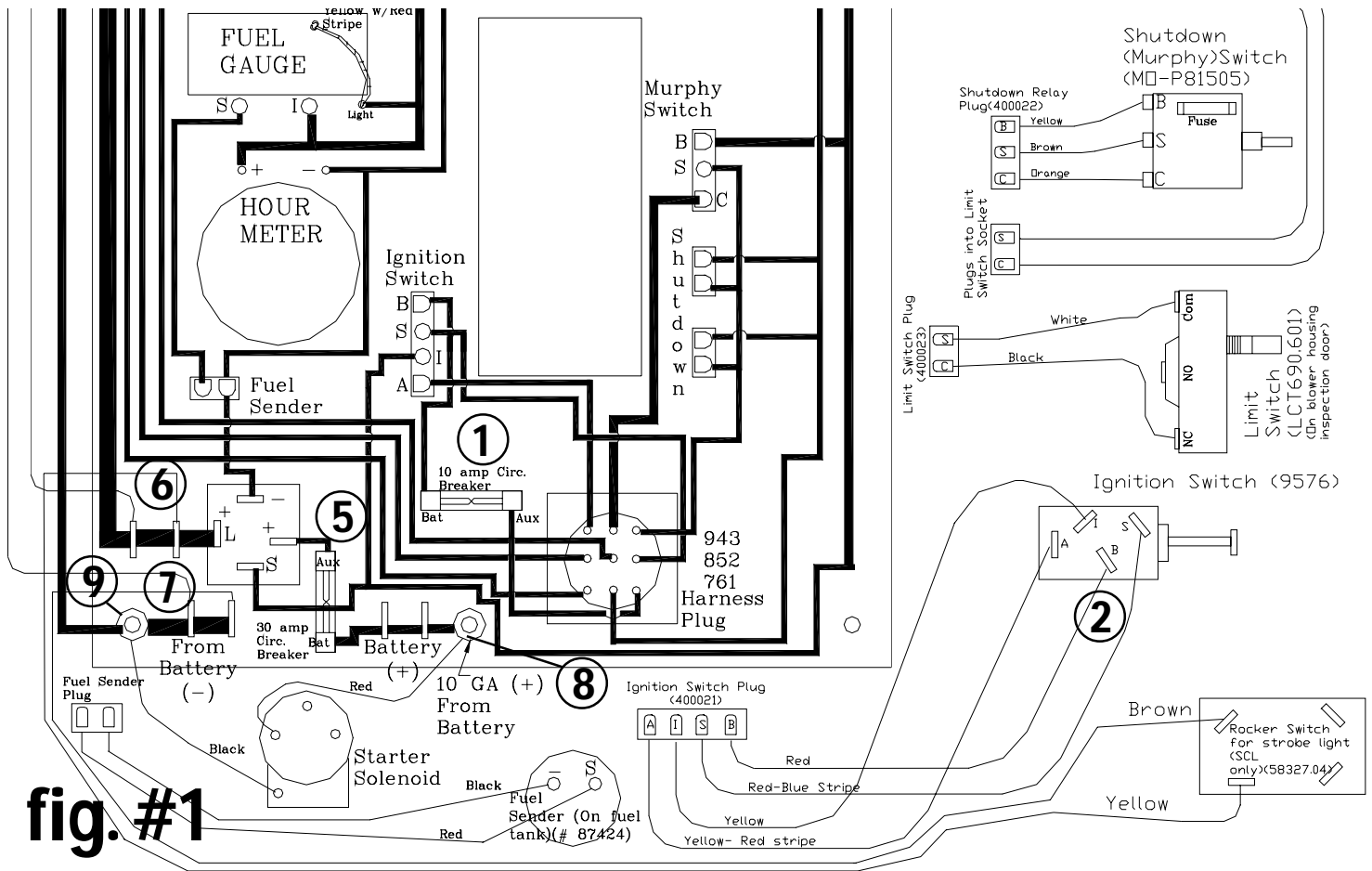

Fig. 3

Circuit Board Troubleshooting Guide



When trying to start the unit, nothing happens, the gauge lights do not work and engine does not try to turn over.

1. Pull out ignition switch one notch to accessories.
2. Take a test light, check for current at both the Bat and Aux terminals on the 10 amp circuit breaker (item #1 above).

BOTH TERMINALS ON THE 10 AMP BREAKER HAVE CURRENT

3. If both terminals have current, the breaker is working correctly. Then check for current on the B terminal (item #2 with red wire attached) on the ignition switch. If there is current, the ignition switch (part# 9576) is bad, replace ignition switch. If there is NOT current on the B terminal, replace Ignition switch plug (part# 400021).

BAT TERMINAL ON THE 10 AMP BREAKER HAS CURRENT, BUT AUX DOES NOT

4. If the BAT terminal has current then the circuit breaker has tripped, it needs to be reset. Pull the breaker out and wait for 1 minute, put the breaker back in exactly the same way it was taken out. The AUX side of the breaker should be to the right. The sides are labeled in very small print on the breaker itself. This should correct the problem.

Circuit Board Troubleshooting Guide

Page 2

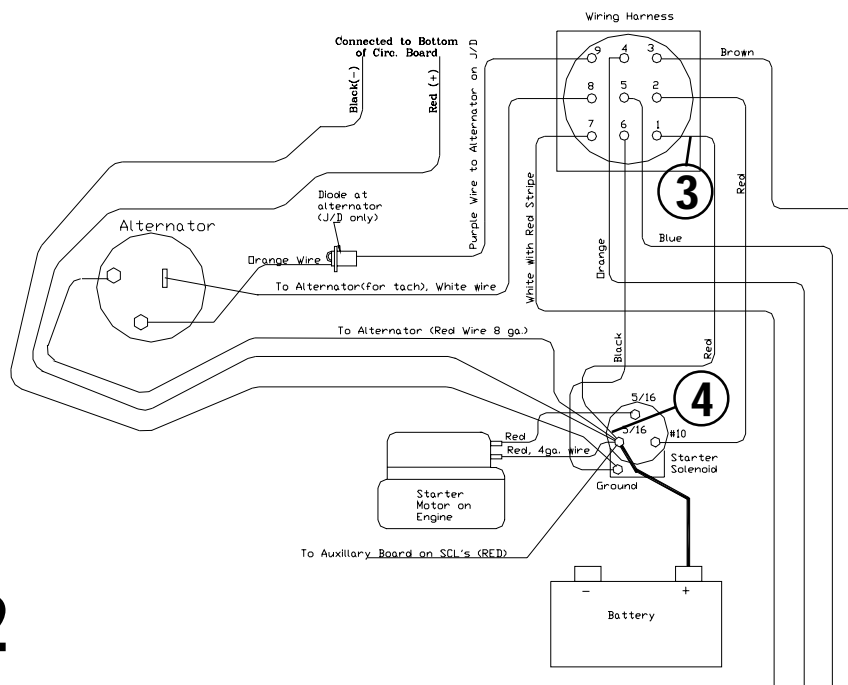

fig. #2

BAT TERMINAL ON THE 10 AMP BREAKER DOES NOT HAVE CURRENT.

5. Find the engine wiring harness where it connects to the circuit board, (keep connected) find the #1 terminal (#3 above) probe the wire by penetrating through the wire insulation with the test light. If it does have current the circuit board is bad and needs to be replaced. If it does not have current locate the starter solenoid (#4 above) and probe the same red wire right at the solenoid. If there is current at the solenoid, the engine wiring harness is faulty and needs to be replaced. If there is not current at the solenoid, the battery or battery connections are defective.

When trying to start the unit, the gauge lights work but the engine does not try to turn over.

1. Pull out ignition switch one notch to accessories.
2. Put a test light on the BAT and the AUX terminals on 30 amp circuit breaker (item #5 -- fig #1 on first page).

BOTH TERMINALS ON THE 30 AMP BREAKER HAVE CURRENT.

3. If there is current on both terminals, then the circuit breaker is working properly. Now locate the positive terminals to the left of the electrical relay (item #6 -- fig.#1 front page). Check for current, if there is not current, the relay is bad-- replace relay. If there is current at #6, check the ground terminals (item #7 -- fig. #1 front page) use any known positive terminal for the "hot" side. If the ground is good, the circuit board is bad and needs to be replaced. If the ground is not good, check the ground wires for shorts, cuts or nicks. Replace all faulty wires.

Circuit Board Troubleshooting Guide

Page 3

BAT TERMINAL ON THE 30 AMP BREAKER HAS CURRENT, BUT AUX DOES NOT.

4. If the BAT terminal has current, then the circuit breaker has tripped, it needs to be reset. Pull the breaker out and wait for 1 minute, put the breaker back in exactly the same way it was taken out. The AUX side of the breaker should be at the top. The sides are labeled in very small print on the breaker itself. This should correct the problem.

BOTH TERMINALS ON THE 30 AMP BREAKER DO NOT HAVE CURRENT.

5. If there is no current at either terminal of the 30 amp breaker then check the 10 gauge Red wire (item #8-- fig. 1, first page) for current. If there is current at this terminal, check the 10 gauge Black wire (item #9 -- fig. 1, first page) ground cable to make sure the board is properly grounded. Replace or tighten any shorted or loose wires. If there is no current at Red 10 gauge wire terminal (Item #8) then trace the red wire back to the starter solenoid and check for current there. If there is no current there check the battery and the battery cables for any possible shorts.

IF THESE PROCEDURES DO NOT ISOLATE YOUR PROBLEM PLEASE CALL ODB AT 800-446-9823 SO THAT WE MAY ASSIST YOU.

Auto PTO Linkage Adjustment

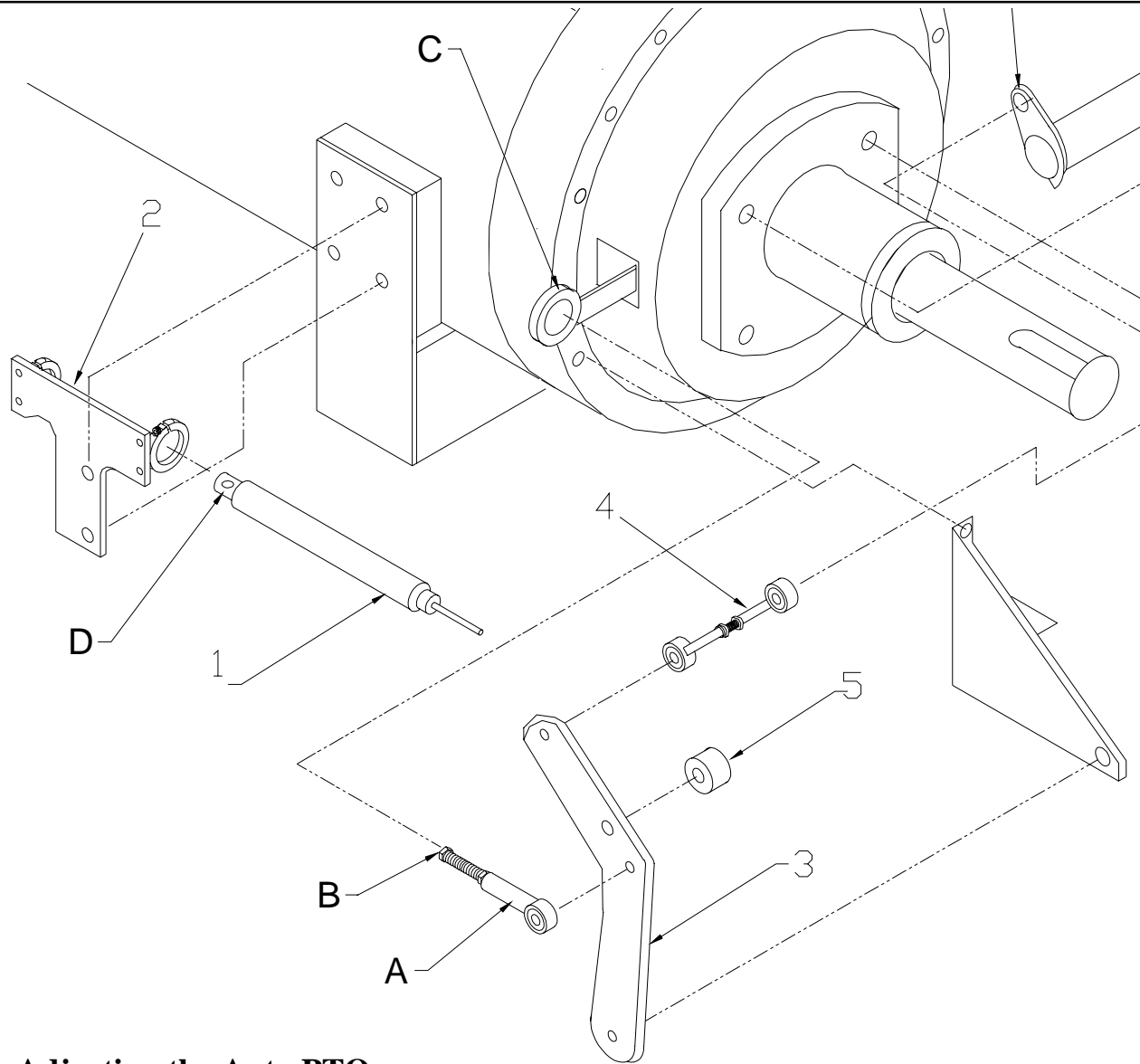

Adjusting the Auto PTO:

1. Make sure the engine is OFF and remove the negative battery cable to ensure the unit can not accidentally be started. Put the PTO in gear so that the PTO handle is at 90 degrees or pointing straight up.
2. Locate the throwout arm which protrudes from the clutch housing (Fig. C).
3. Remove the spring that is attached to the throwout arm and sheet metal.
4. Grab the end of the throwout arm to check for movement or “play”. When properly adjusted the arm should move 3/4” to 1” when in gear.
5. If the arm does not move in this range, locate the PTO linkage (Fig. A), then turn the adjuster nut (Fig. B) clockwise to increase tension, counter clockwise to decrease tension.
6. If there is no adjustment left then the clutch disk most likely needs to be checked/replaced.
7. After adjustment reapply the return spring and negative battery cable.

Units with Clutch Assist Cylinder:

1. Check for movement in the throw out arm as described above.
2. If there is not sufficient “play” in the throwout arm check the setting of the clutch assist cylinder. The cylinder may be impairing the movement of the throwout arm if not properly adjusted.
3. Adjust the cylinder by turning the adjusting nut (Fig. D) counter clockwise to around setting 7.
4. Once the clutch assist cylinder is properly adjusted, adjust the PTO as described in the first section.

Hydraulic Boom Trouble Shooting Guide

July 2002 and after

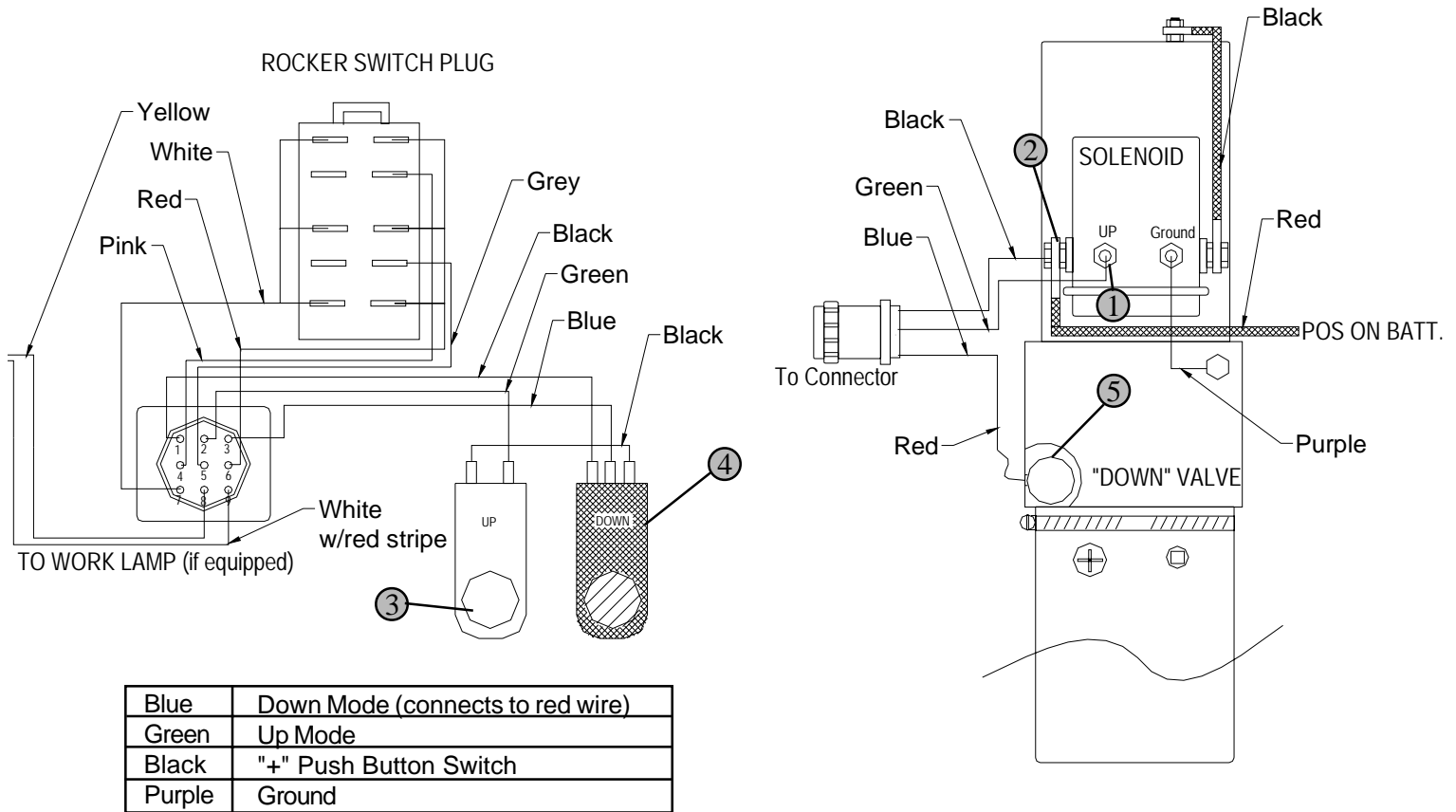

BOOM WILL NOT GO UP

1. Check the fluid level in the reservoir.
2. Using a test light make sure there is current at the outside solenoid post (item#2), this has a 4 gauge Red battery cable attached. If no current is found check the battery condition and battery connections.
3. If there is current at this post, depress the "up" button (item# 3), while pressing the "up" button check for current at the middle post (item# 1), it has a blue wire attached. If there is current at the post (item# 1) the solenoid may be defective.
4. Run a jumper wire connecting #1 and #2. This will test the motor, bypassing the solenoid. If the boom raises, the motor is okay (motor part# MP-08053) but the solenoid is bad and needs to be replaced. Solenoid part number is MP-03335.
5. If there is NO current at the post (item# 1) check the wiring between the switch and the solenoid. If the wiring checks out okay, the switch is bad and needs to be replaced.

BOOM WILL NOT GO DOWN

1. Using a test light make sure there is current at the outside solenoid post (item#2), this has a 4 gauge Red battery cable attached. If no current is found check the battery condition and battery connections.
2. Press and hold the "down" button (item# 4), take a test light and probe through the insulation and test for current on the red wire at the valve (item#5).
3. If there is current, the valve is bad and need to be replaced. Valve parts number is MP-00488. If there is NO current, check the wiring between the switch and valve, especially any connections. If the wiring checks out okay, the switch is bad and needs to be replaced.

IMPELLER INSTALLATION AND REMOVAL

REMOVAL



CAUTION: Before removing the blower housing face remove the negative battery cable to ensure unit can not be started.

1. The blower housing face must be removed to gain access to the impeller. Use an overhead crane or forklift to support the face while removing.
2. Once the face has been removed, remove the shaft protector (Fig. 1 or 2).
3. Saturate the shaft and bushing using a penetrating lubricant to help loosen the bushing. Clean any grease or debris from the bushing and shaft.
4. Remove the 3 bolts attaching the bushing to the impeller.(Fig. 3) Being careful not to break the bolts. If a set screw is on the lip of the bushing, loosen it using an allen wrench.(Fig. 4)
5. Using two of the bolts that were just removed screw those bolts into the threaded holes on the bushing. Drive the two bolts into the bushing.(Fig. 5) This will separate the bushing from the impeller. Alternate from one bolt to the other driving only about a 1/4" at a time to keep the bushing coming out straight. It is imperative to keep the bushing straight to remove it.

IMPORTANT: Be sure to drive the bushing out evenly or it will get in a bind making removal much harder.

6. If the bushing does not come off using the two bolts, drill and tap several additional 3/8-16 holes around the bushing. Using Grade 8, 3/8-16 - 2 inch bolts, alternately drive the bolts 1/4" at a time to remove the bushing. **KEEP THE BUSHING STRAIGHT** while removing.

IMPORTANT: If additional holes were drilled in the bushing, it can not be reused. It must be replaced.

7. Once the bushing has been removed use an overhead crane or other suitable device to help lift the impeller out of the blower housing.
8. At this point it would be a good idea to inspect the blower housing liners and blower housing for any damage or wear. Any damage or wear to the liners should be fixed by replacing the liners immediately.

Fig. 1



Belt
Drive

Fig. 2



Direct
Drive

Fig. 3



Fig. 4



Fig. 5



IMPELLER INSTALLATION AND REMOVAL--Cont.

INSTALLATION



CAUTION: Before removing the blower housing face remove the negative battery cable to ensure unit can not be started.

1. Clean the shaft of any debris and remove any rust using a 120 grit emory cloth.
2. Put a generous coat of anti-sieze compound completely around the shaft. This will aid in removing the bushing and impeller the next time.

IMPORTANT: Use an anti-sieze compound on the shaft and bushing to keep the bushing from “welding” itself to the shaft. This makes removal much easier.

3. Using an overhead crane or other suitable lifting device lift the impeller on to the shaft. Turn the impeller to align the keyways of the shaft with the keyway in the impeller.
4. Insert key into the keyway. A light sanding of the keyway may be needed, as well as a few light blows with a rubber mallet.
5. Apply a generous coat of anti-sieze compound to the outside of the bushing being sure to cover any area that will come in contact with the impeller.
6. Tap the bushing onto the shaft aligning the keyways.
7. **BELT DRIVE UNITS:** Align the bushing and key to be flush with the end of the shaft (Fig 1).

DIRECT DRIVE UNITS: The bushing and key should protrude from the shaft about 1/2 inch (Fig. 2).

8. Put the 3 bolts into the non-threaded holes and drive them into the impeller holes evenly. Alternate between the three bolts as you drive the bolts in. Torque to 40 to 50 lbs/ft. There should be a gap of 3/8” to 1/2” between the bushing and the impeller.

IMPORTANT: Slowly spin the impeller by hand making sure that the back of the impeller is not hitting any of the bolt heads located at the back of the blower housing.

9. If the bushing has a set screw on it, tighten the screw snug with an allen wrench (Fig. 3). This will help keep the key in place.
10. Install the shaft protector on to the shaft (Fig. 4 or 5).

Fig. 1



Fig. 2



Fig. 3



Fig. 4

Belt
Drive



Fig. 5

Direct
Drive





Flange Bearing Installation - Side 1

(Blue Brute Bearings)

FIGURE #1

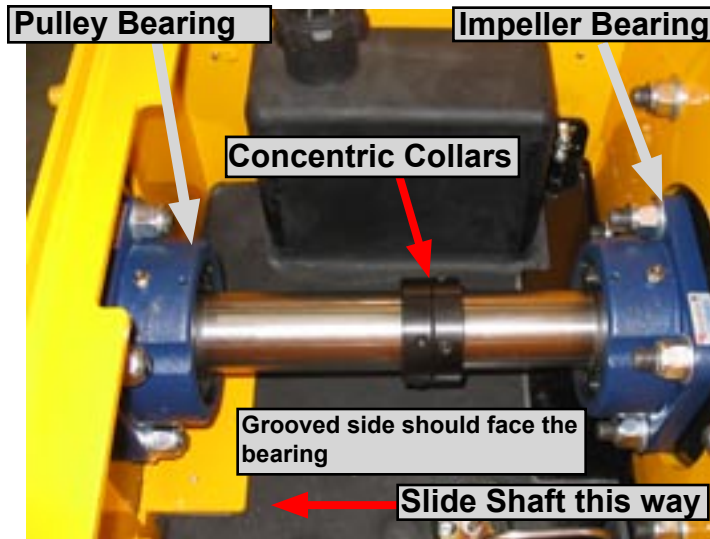

FIGURE #2

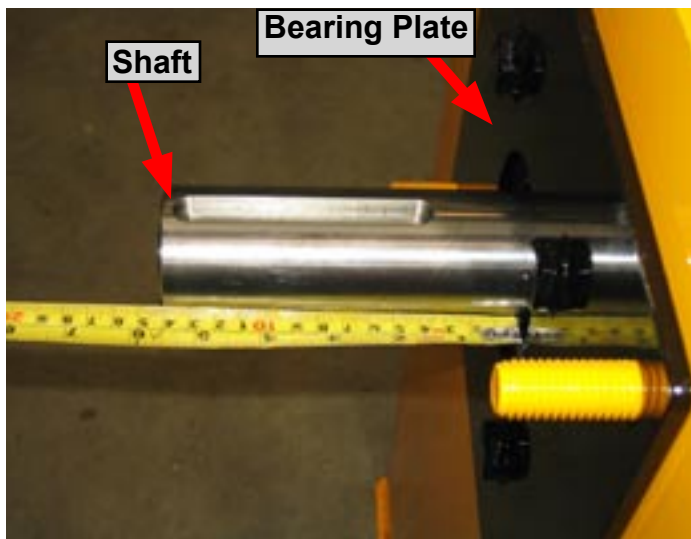

FIGURE #3



1. Place the bearings on to the black bearing plates inside the pedestal. Hand tighten the bolts onto the nuts at this point.
2. Slide the shaft through the back of the impeller bearing and half way to the pulley bearing. The shaft should fit tight. Clean the shaft and remove any burrs if necessary. Also lightly polishing it with a fine emery may ease installation.
3. Before going through the pulley bearing, place both concentric collars (black collars) onto the shaft (figure #1). Make sure the grooved side is facing the bearing.
4. Continue sliding the shaft through the pulley bearing until the shaft protrudes out from the pulley side 5-5/8". (Figure #2)
5. Now slide the concentric collar toward the respective bearing making sure the grooved side is toward the bearing.
6. Turn the concentric collar clockwise until it slips over the inner ring extension and engages the eccentric. Turn by hand until the parts are locket together.
7. Place a punch or drift in the blind hole in the collar and strike it sharply to lock the collar and ring tightly together (figure #3)
8. Tighten the set screws with an Allen wrench until the set screw stops turning and the Allen wrench starts to spring. (Figure #4)
9. Completely tighten all four of the nuts to secure each bearing.

OVER... →

FIGURE #4





Flange Bearing Installation - Side 2

(Blue Brute Bearings - Steel Collar Installation)

FIGURE #5

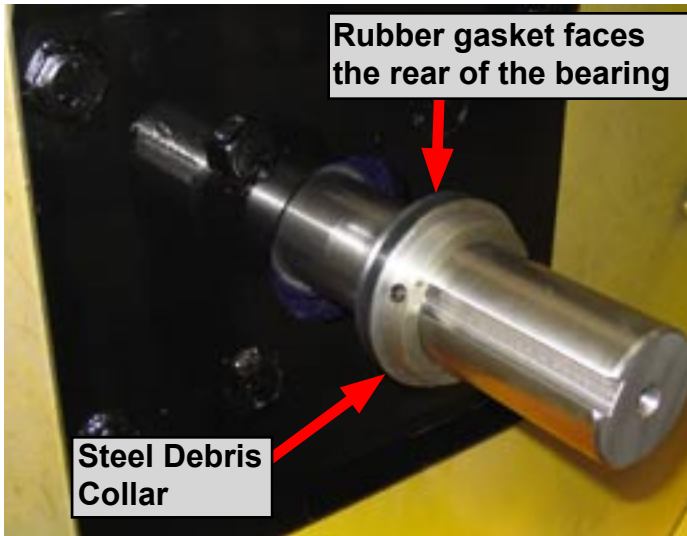

1. Now move to the blower housing where the shaft comes out from the bearing. Put the steel debris collar (chrome color with a rubber seal on one side) onto the shaft with the rubber gasket side facing the rear of the bearing (away from the impeller). See Figure #5.
2. Push the steel collar seal up to the bearing and make sure the groove in the collar goes inside the groove in the bearing. (Figure #6) This creates the sealed fit to keep debris out of the bearing.

NOTE:

3. If the collar is too large for the hole in the bearing plate, a "new style" bearing plate will need to be ordered that has a larger diameter hole. Units manufactured before April 2002 will most likely need to be converted to the new bearing plate (part number LCT600.603 {all but LCT6000} and LCT630.104A for the LCT6000. This plate is for the blower housing or impeller side only. The pulley side bearing does not use the steel debris collar.
4. Completely tighten the two Allen head screws. See figure #6.

NOTE:

Each bearing comes with a steel debris collar but it will be used only on the bearing on the impeller side. You may discard the other collar if you're replacing the pulley bearing.

FIGURE #6



Service Section

Replacing the Blower Housing Liners

figure 5.5a

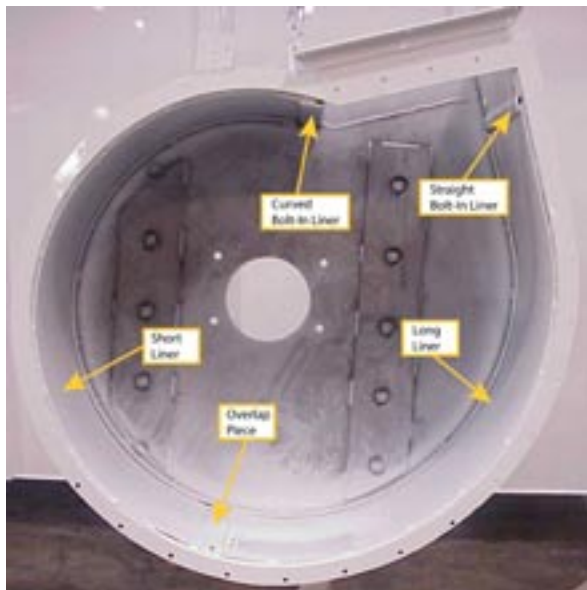

⚠ WARNING

Thoroughly read and understand the safety and pre-operating sections of this manual before working on the unit.

⚠ WARNING

Make sure the negative battery cable is disconnected before opening the blower housing.

Review the safety section of this manual before attempting these procedures. To gain access to the interior of the blower housing please see the previous sections.

Removing and installing the Liners (refer to 5.5a and 5.5b):

⚠ WARNING

Keep all fuel and fuel fumes away from the unit when grinding or welding. Work only in a well ventiated area.

1. Unbolt the the blower housing face as described previously in this manual.
2. Remove the curved and straight bolt-in liners by removing the appropriate bolts.
3. With a grinder cut out the remaining welds to free the liners. DO NOT remove the "stop piece" at the bottom of the housing.

TO INSTALL:

1. Place the short liner into lip at the rear of the housing and line up the bottom of the liner with the "stop" at the bottom of the housing. The short liner has the overlap piece on it and should be installed as shown in the pictures at the left.
2. Tack weld the liner in place every 8 to 10 inches to help keep the liner in place.

figure 5.5b

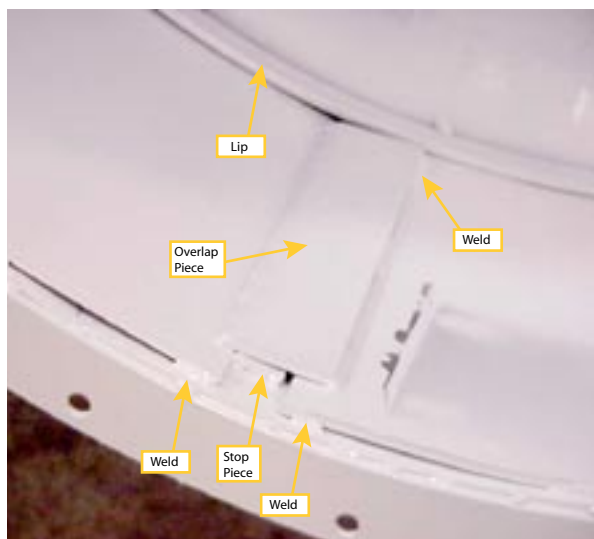

Service Section

Replacing the Blower Housing Liners; continued,

figure 5.5a

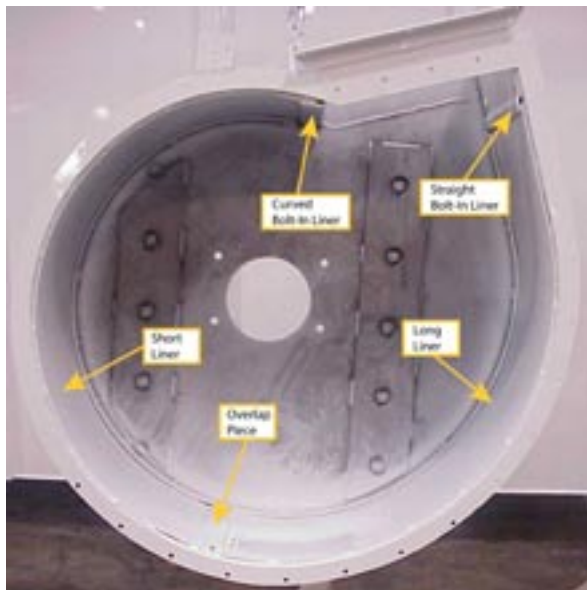

⚠ WARNING

Thoroughly read and understand the safety and pre-operating sections of this manual before working on the unit.

⚠ WARNING

Make sure the negative battery cable is disconnected before opening the blower housing.

Review the safety section of this manual before attempting these procedures. To gain access to the interior of the blower housing please see the previous sections.

Installing the Liners (refer to 5.5a and 5.5b), continued;

⚠ WARNING

Keep all fuel and fuel fumes away from the unit when grinding or welding. Work only in a well ventiated area.

3. Install the long liner the same way as the short liner except the long liner should slip under the overlap piece. Make sure the liner slips under the rear lip and the overlap piece.
4. Tack weld the long liner to the overlap piece and tack weld around the liner as you did on the short liner.
5. Install the two bolt-in liners just as they were removed.

figure 5.5b

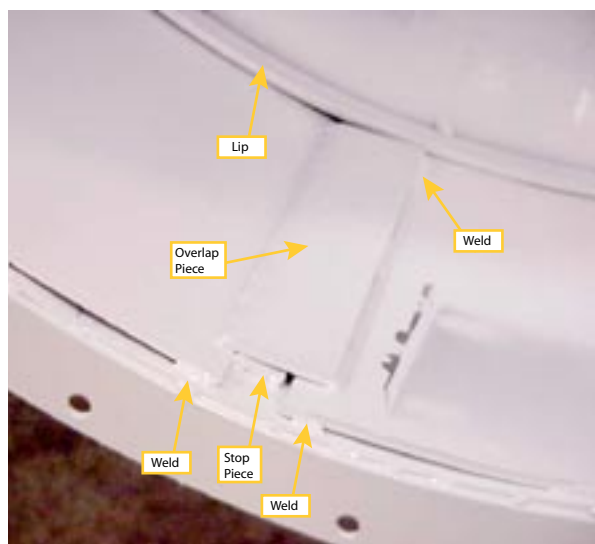



WIRING DIAGRAMS

WIRING DIAGRAMS

- *Engine Wiring Diagram
- *Circuit Board Wiring Diagram
- *Trailer Wiring Diagram
- *Boom Pump Wiring Diagram

ODB COMPANY

5118 Glen Alden Drive
Richmond, VA 23231

800-446-9823

John Deere Engine Harness Wiring Diagram

All Units after February 1999 (Typical)

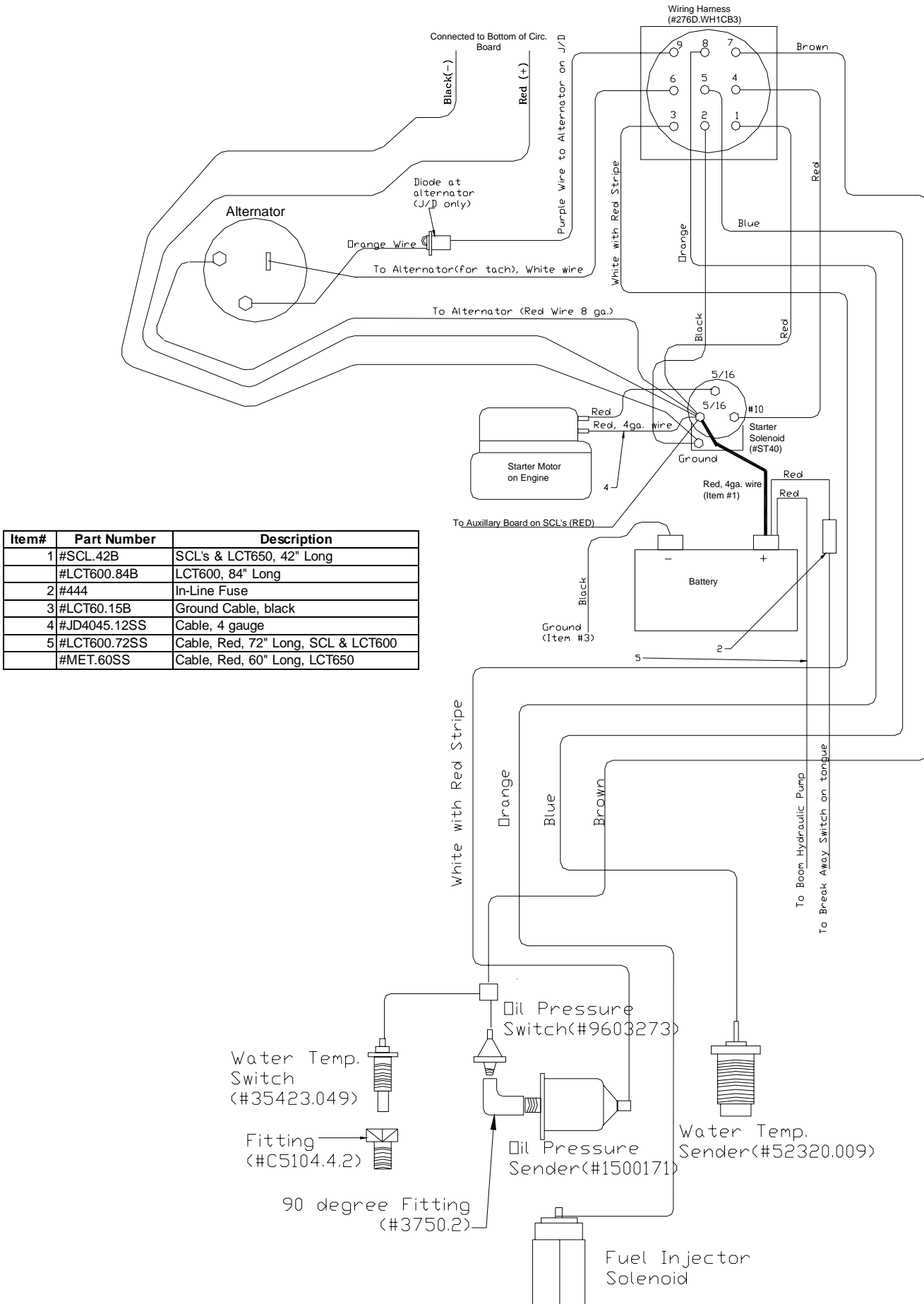

Item#	Part Number	Description
1	#SCL.42B	SCL's & LCT650, 42" Long
	#LCT600.84B	LCT600, 84" Long
2	#444	In-Line Fuse
3	#LCT60.15B	Ground Cable, black
4	#JD4045.12SS	Cable, 4 gauge
5	#LCT600.72SS	Cable, Red, 72" Long, SCL & LCT600
	#MET.60SS	Cable, Red, 60" Long, LCT650

Circuit Board Wiring Diagram

Units after 2001

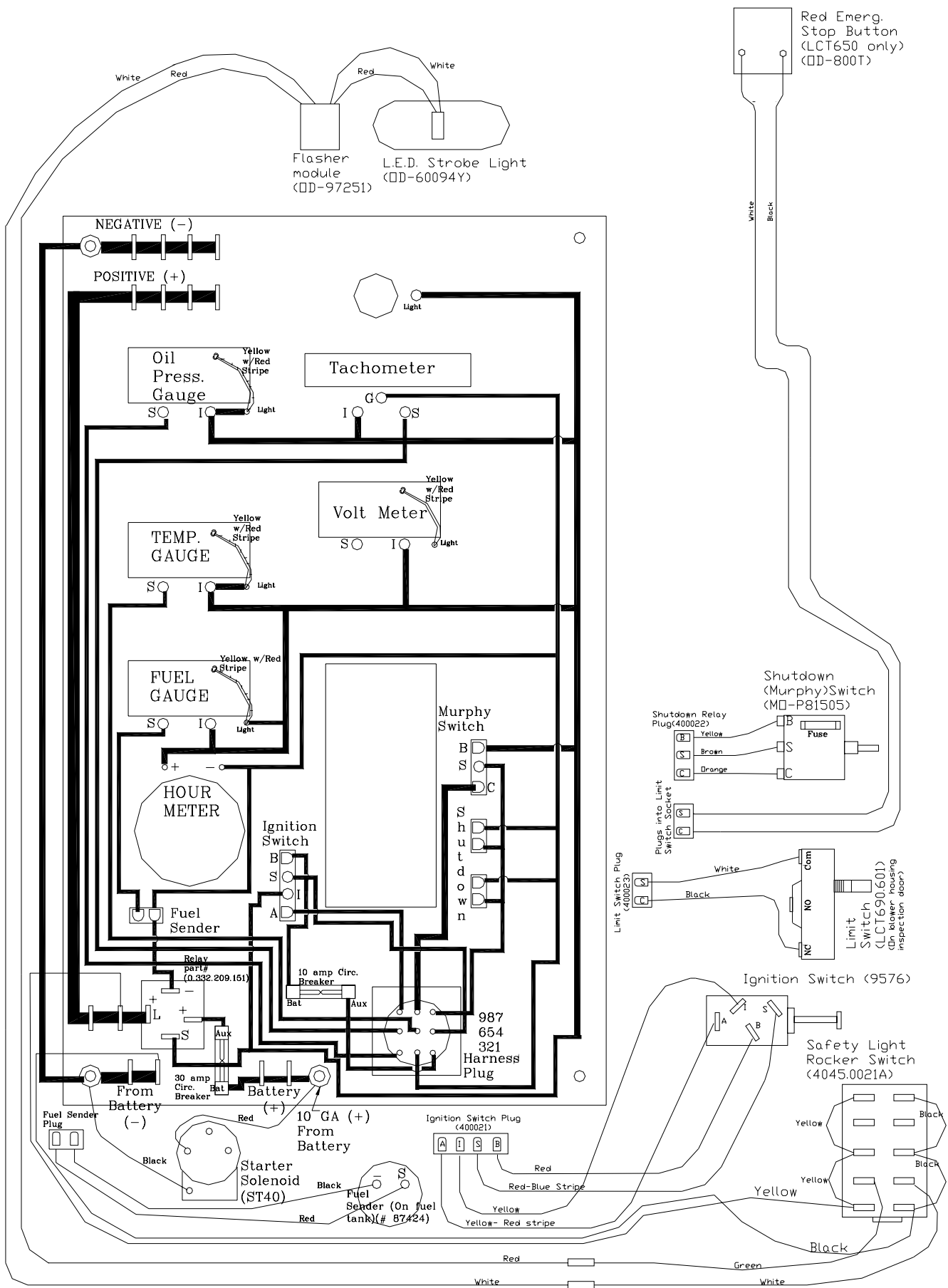

LCT60C, LCT600, LCT6000 and LCT650 Trailer Wiring Diagram

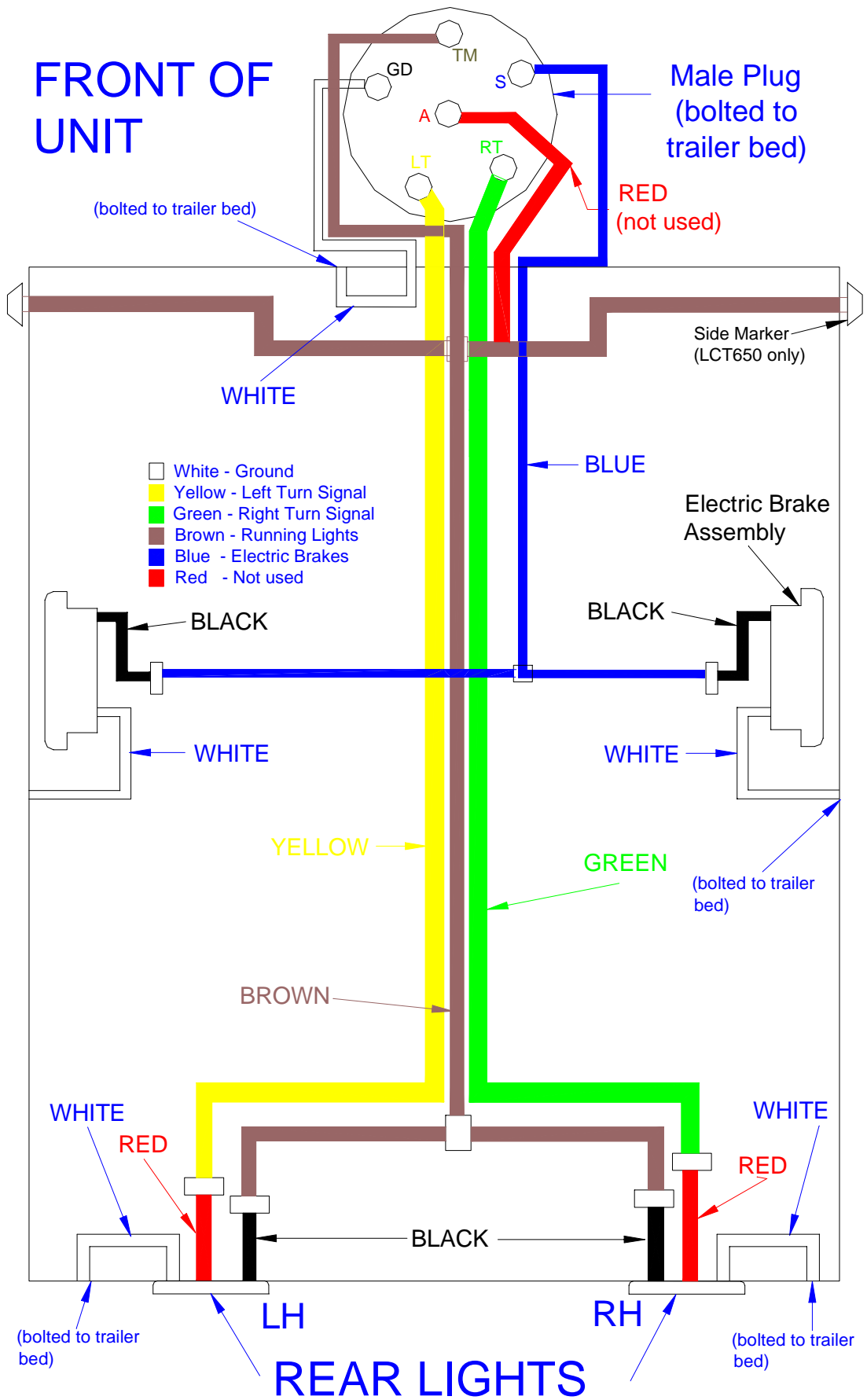

Trailer Plug Wiring Diagram

LCT60C, LC600, LCT6000 & LCT650

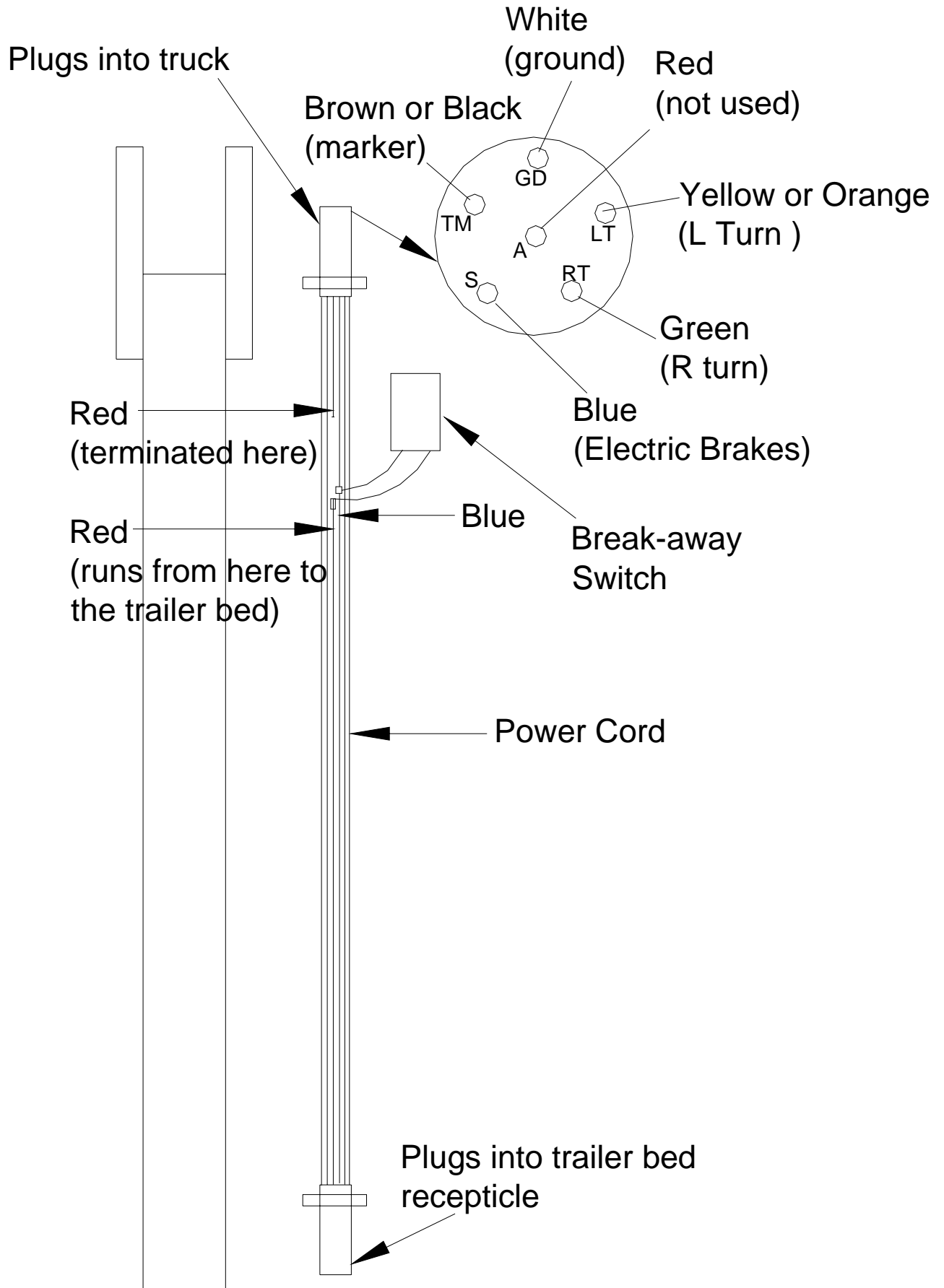

Boom Wiring Diagram

All units except LCT650 July 2002 and after

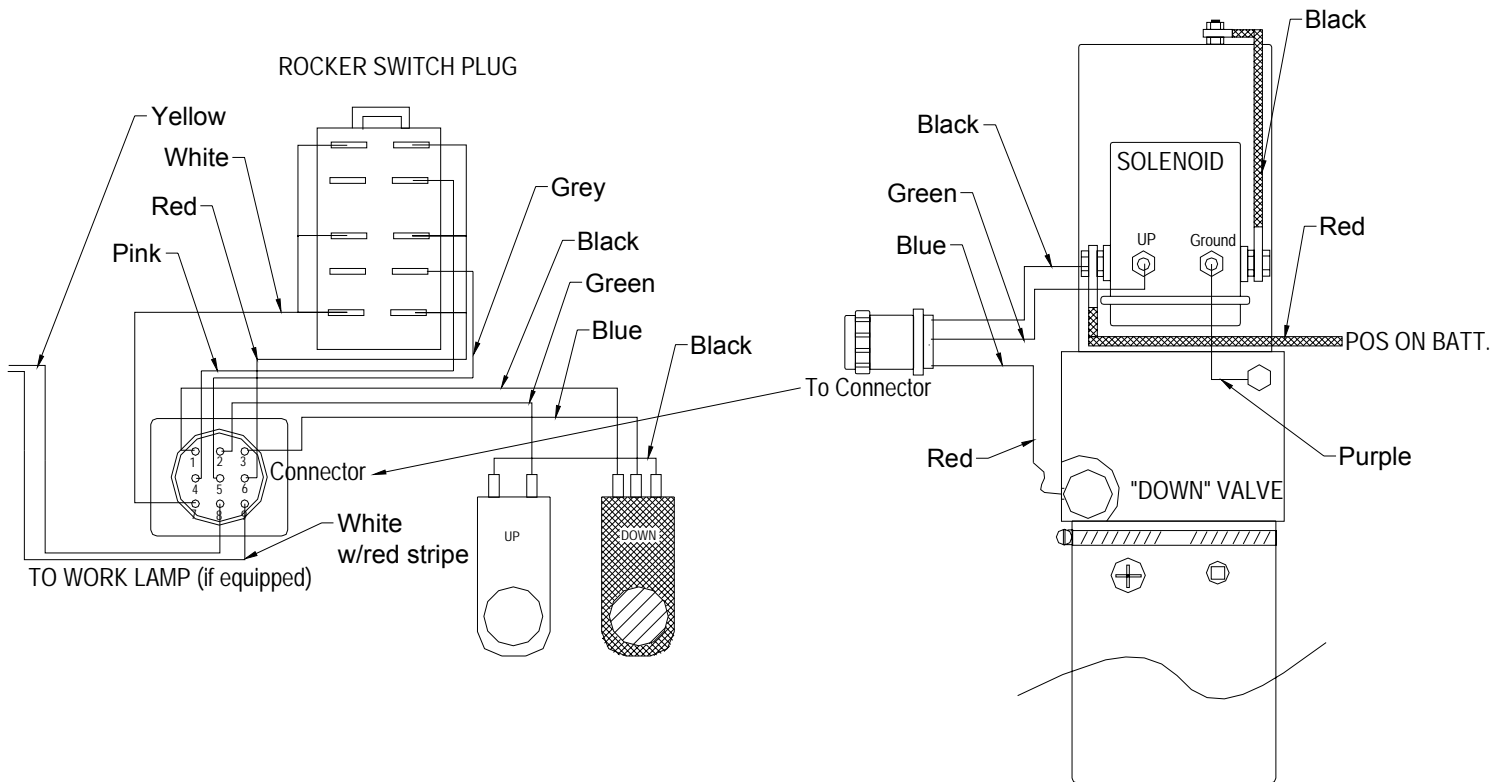

PIN	COLOR	DESCRIPTION
1	Black	"+" Push Button Switch
2	Green	Up
3	Blue	Down
4	Pink	Throttle Fast
5	Grey	Throttle Slow
6	Red	Throttle Switch (+)
7	White	Throttle Switch (-)
8	Yellow	Work Light (+)
9	White w/red stripe	Work Light (-)



PARTS BREAKDOWNS SECTION

Engine Group
Clutch Group
Blower Housing Group
Trailer Group
Hose Boom Group

PARTS BREAKDOWN SECTION

ODB COMPANY

5118 Glen Alden Drive
Richmond, VA 23231

800-446-9823



ENGINE GROUP

- *Instrument Panel
- *Air Cleaner
- *Engine Sheet Metal
- *Engine Mount
- *Engine Exhaust
- *Radiator Assembly
- *Remote Throtte Assembly **(optional)**
- *Chaffe Eliminator **(optional)**

ENGINE GROUP

ODB COMPANY

5118 Glen Alden Drive
Richmond, VA 23231

800-446-9823

Instrument Panel Group

July 2002 and after

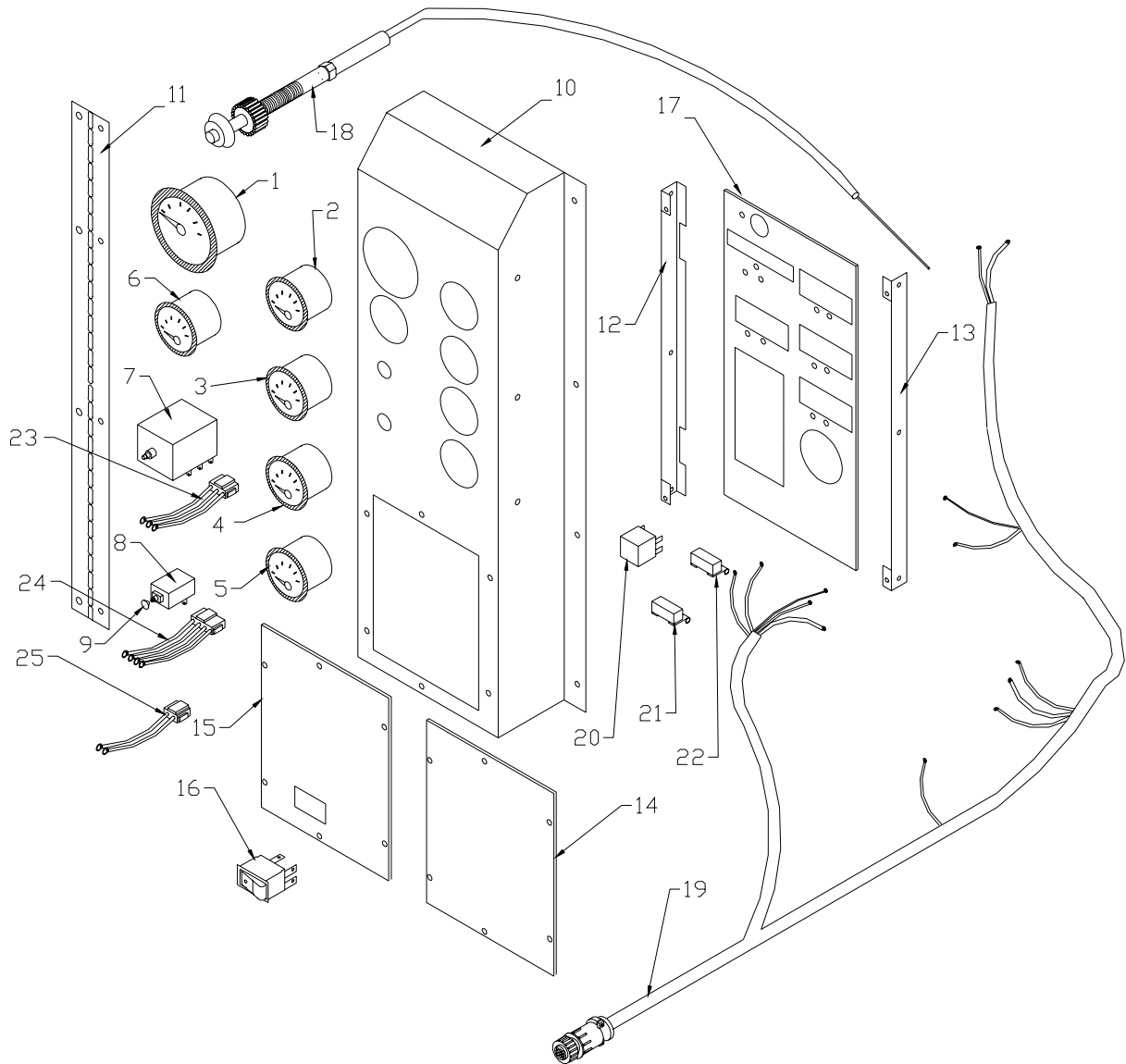

ITEM NO.	PART NUMBER	DESCRIPTION	ITEM NO.	PART NUMBER	DESCRIPTION
*	40003B	Panel Complete (items 1 -17)	13.	4045.099.1	Circuit Board Rail
1.	62547	Tachometer	14.	4045.099.2	Panel Plate (no longer used)
2.	62542	Oil Pressure Gauge	15.	4045.099.4	Panel Plate
3.	62540	Water Temperature Gauge	16.	4045.0021B	Flasher Switch
4.	62551	Fuel Gauge	17.	400020.3	Circuit Board
4.	59414	Blank Gauge (non-elec. fuel gauge units)	18.	LCT623.001	Throttle Cable, J. Deere engines
5.	62538	Hour Meter	19.	276D.WH1.CB3	Wiring Harness, J. Deere engines
6.	62555	Volt Meter	20.	0.332.209.151	Relay on circuit board
7.	MO-P81505	Murphy Switch	21.	100014.10	10 amp circuit breaker
8.	9576	Ignition Switch	22.	30410.30	30 amp circuit breaker
9.	UU-8138.03	Knob for Ign. Switch	23.	400022	Murphy Switch Plug
10.	4045.099	Instr. Panel Housing	24.	400021	Ignition Switch Plug
11.	4045.2107C	Hinge For Instrument Panel	25.	400023	Limit Switch and Stop Switch Plug (stop switch -LCT650 only)
12.	4045.099.1	Circuit Board Rail			

Strobe Light Parts Group

John Deere Engines 2002 and after

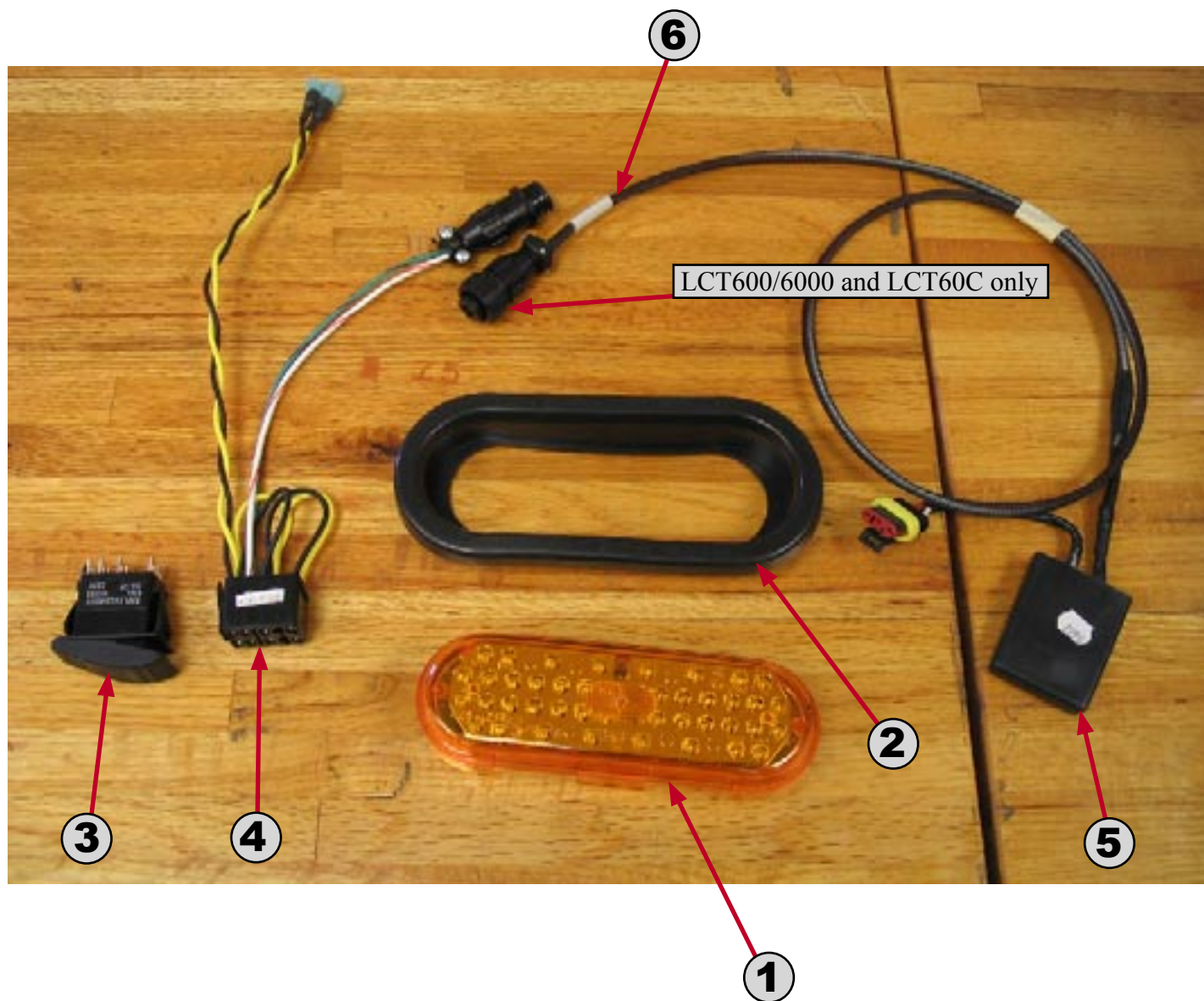

ITEM NO.	PART NUMBER	DESCRIPTION
1.	STD.2213	L.E.D. Strobe Light with internal flash module, 2004 and after
	60094Y	L.E.D. Light only, through 12/2003
2.	60700	Grommet
3.	4045.0021B	Rocker Switch
4.	4045.0024B	Switch Wiring Harness
5.	97251	Strobe Module (makes the light flash), LCT650, through 12/2003
6.	97251.WH	Strobe Module with 4 prong connector on LCT60C and LCT600/6000 only, through 12/2003
	STD.2214	Wiring Harness, rocker switch to light, 2004 and after

NOTE: 01/01/04 we changed to a new style strobe light that has an internal flash module, thus a separate flash module is not needed.

AIR CLEANER GROUP

Approx. 08/96 and after

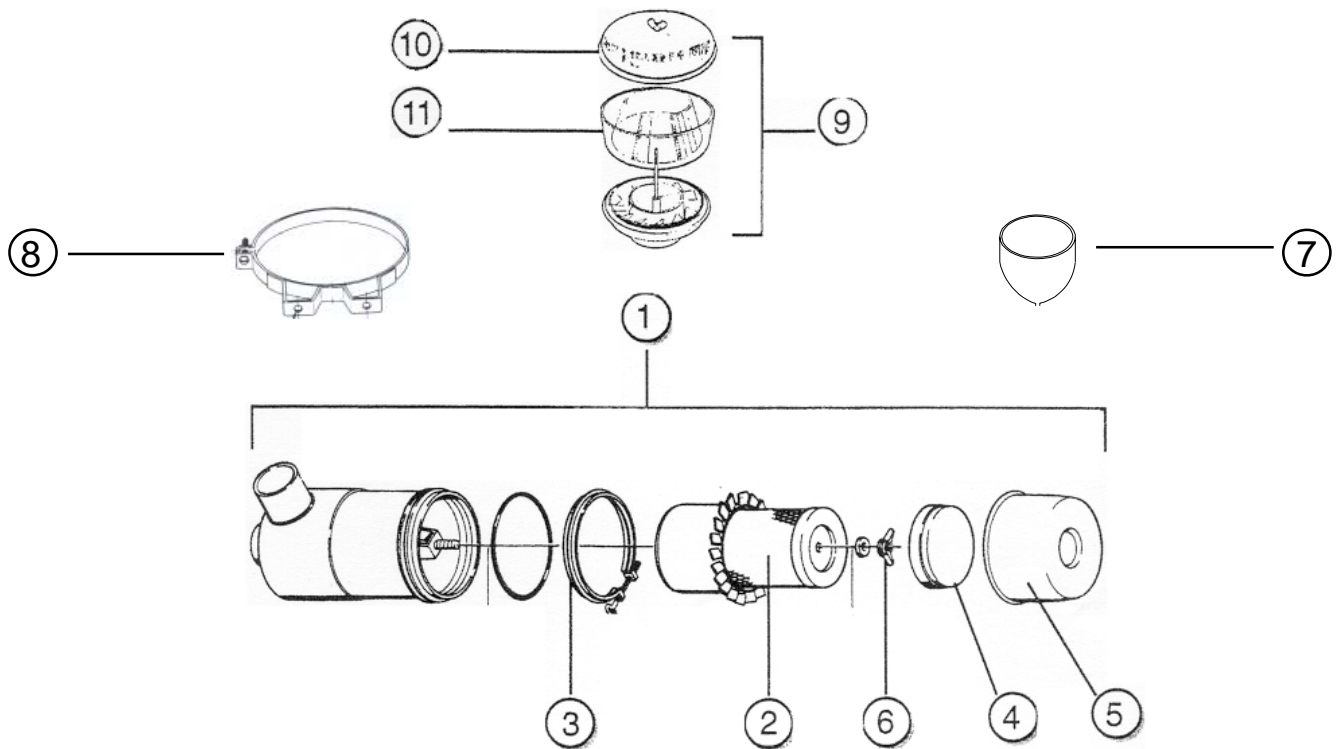

John Deere *
(4 cyl. regular)
only used bef. 04/04
6.5" Diam.

JD 4 cyl. Turbo,
JD 6 cyl.
Ford,**
8" Diam.

1.	OD-G065012	UU-G080023	Air Cleaner Assembly w/filter
2.	P18.1052	P18105.4	Filter Element
3.	P002940	P003951	Clamp
4.	P102510	P102980	Rubber Baffle
5.	P102805	P103113	Dust Cap
6.	P101870	P101870	Wing Nut
7.	P103198	N/A	Vacuator Valve (rubber)
8.	P007191	P004307	Mounting Bands (to sheet metal)
9.	H001251	H001249	Pre-Cleaner Assembly
10.	P020648	P020648	Bowl Cover
11.	P020227	P020227	Bowl

* Before July 1999, LCT650 with John Deere engines used G080023 (8" diam,)air cleaners and H001249 pre-cleaners.

** May 2004 and after all ODB LCT's and SCL's use UU-G080023 8" diameter filters as standard.

Sheet Metal Group, except LCT650

John Deere 4045D, 4045T and 6068D after 08/96

Ford BSD444 & 666 Diesel after 09/97

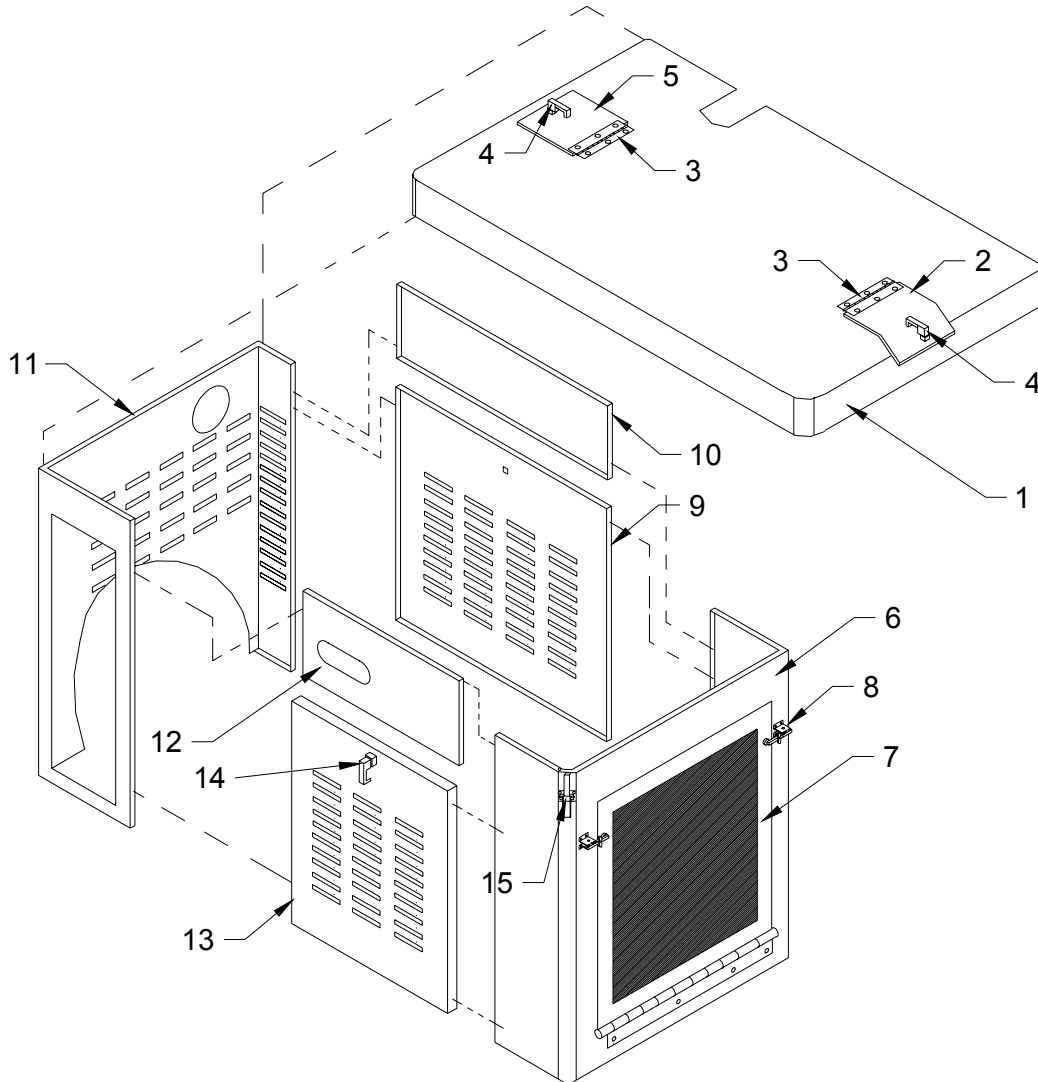

ITEM NO.	PART NUMBER	DESCRIPTION	ITEM NO.	PART NUMBER	DESCRIPTION
1.	4045.2102	Hood, except SCL800	10.	4045.2106	Upper Side Panel, LH
	4045T.2102	Hood, JD Turbo, exc. SCL		4045.2106A	Upper Side Panel, LH-turbo
	6068.2102	Hood, 6 cyl. diesel, exc. SCL		6068.2106	Upper Side Panel, LH- 6cyl diesel
	4045.2102S	Hood, SCL800 JD natural	11.	4045.2112	Rear Panel, J/D natural and J/D turbo not on SCL's; Ford engines not on SCL
	4045T.2102S	Hood, SCL800, JD Turbo		4045.2112T	Rear Panel, SCL's with JD turbo
	6068.2102S	Hood, SCL800, JD 6 cyl. diesel		4045.2112S	Rear Panel, Ford SCL's
2.	4045.2102A	Radiator Access Door	12.	4045.2105	Upper Side Panel, RH -02/01
3.	4045.2102C	Rad. Access Door Hinge		4045.2105A	Upper Side Panel, RH 03/01-
4.	LCT60.624A	Lift And Turn Latch		6068.2105	Upper Side Panel, RH 6 cyl diesel
5.	4045.2102B	Oil Fill Access Door	13.	4045.2108	Panel Door, RH
6.	4045.2101	Front Panel		6068.2108	Panel Door, RH 6 cyl. diesel
7.	4045.0018	Radiator Screen	14.	LCT60.624A	Lift and Turn Latch
8.	LCT650.114	Radiator Screen Clamp	15.	LCT609.602	Overcenter Latch
9.	4045.2109	Panel Door, LH			
	6068.2109	Panel Door, LH 6 cyl. diesel			

Engine Mount Group

John Deere 4045D, 4045T and 6068D after 08/96

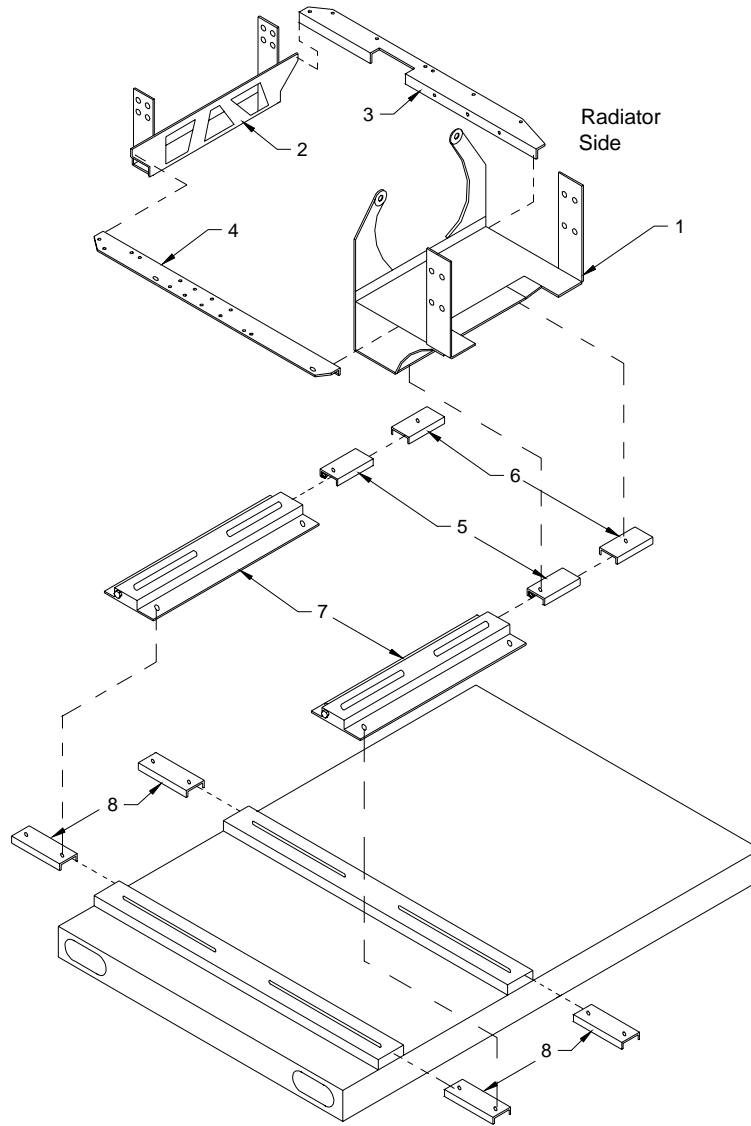

ITEM NO.	PART NUMBER	DESCRIPTION
1.	4045.2151	Engine Mount, Front
2.	4045.2152	Engine Mount, Rear
3.	4045.2154	Side Rail, LH
	6068.2154	Side Rail, LH, J/D 6 cyl. diesel
4.	4045.2153	Side Rail, RH
	4045.2153B	Side Rail, RH, LCT650 only
	6068.2153	Side Rail, RH, J/D 6 cyl. diesel
5.	LCT604.603.1	Engine Adjuster Nut, belt drive units only
6.	LCT604.603.1A	Engine Adjuster Bracket, belt drive units only
7.	LCT604.603.2	Adjustable Motor Mount, belt drive units only
8.	LCT604.603.B	Engine Base Adjuster (LCT600/6000 only)

Muffler (Exhaust) Assembly

LCT's only (not SCL's) May 2004 and after

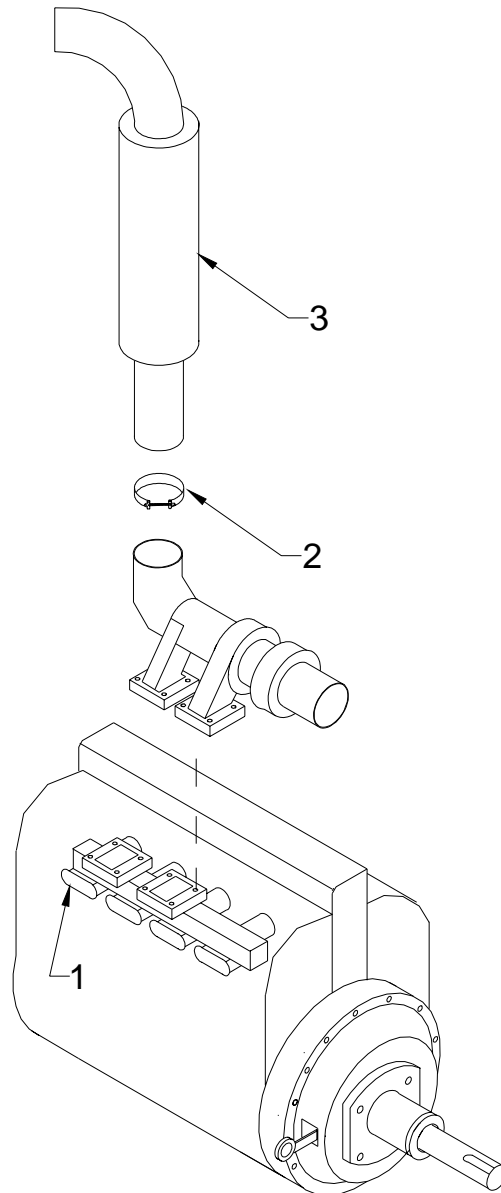

ITEM NO.	PART NUMBER	DESCRIPTION
1.	JD-R123171	Exhaust Manifold, LCT's with turbo only
2.	STD.2702	Clamp, muffler
3.	650.2701	Muffler, LCT600 /6000/60C/650

Notes: The above parts are only for John Deere TURBO engines only. May 2004 and after, all ODB units use Turbos as standard. ODB serial numbers 3897, 3900 and after have John Deere Turbo engines.

Radiator Assembly Group

John Deere after August 1996

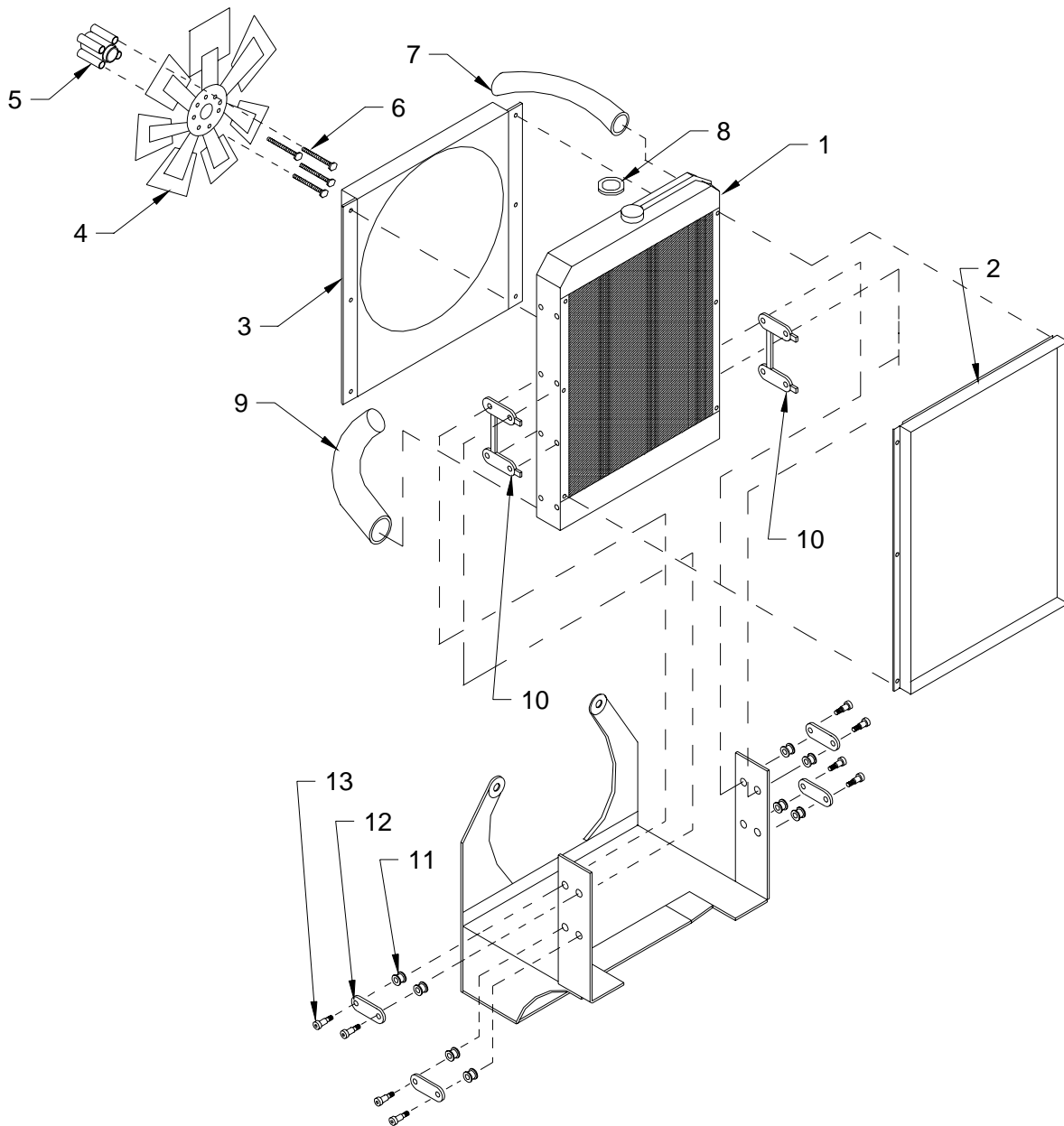

ITEM NO.	PART NUMBER	DESCRIPTION	ITEM NO.	PART NUMBER	DESCRIPTION
1.	4045.9500	Radiator, 4 cyl.	7.	81331	Upper Radiator Hose
	4045.9501	Radiator, turbo and 6 cyl.	8.	C.89C.022.5010	Radiator Cap
2.	4045.2190B	Front Fan Shroud	9.	4045.9681	Lower Radiator Hose
3.	4045.2190A	Rear Fan Shroud	10.	4045.2151E	Radiator Shim
4.	AT35158	Radiator Fan	11.	2651.26012	Radiator Grommet
5.	R128443	Fan Spacer	12.	4045.2151F	Radiator Bolt Bracket
6.	G8M8X090	Spacer Bolts, 4 req.	13.	ZSB.500.750	Shoulder Bolt

Remote Clutch and Remote Throttle Assembly after March 2002- ver. 2

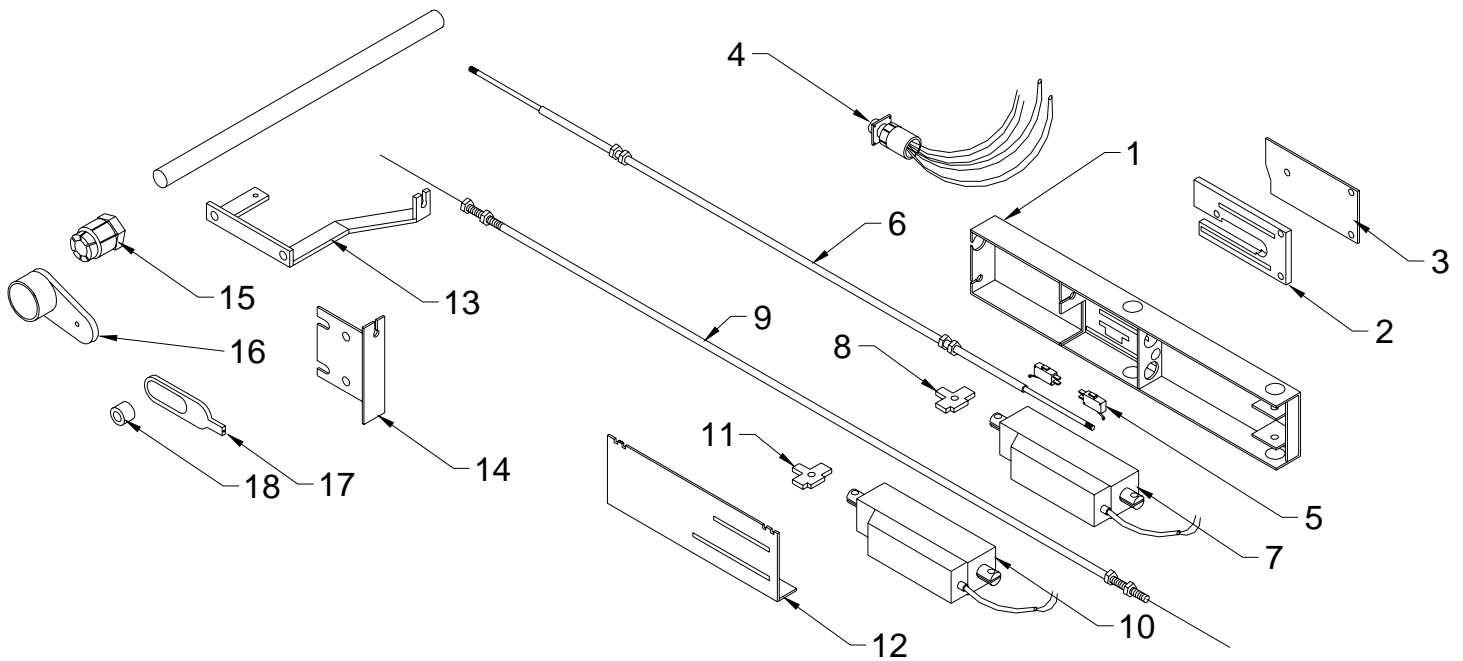

ITEM NO.	PART NUMBER	DESCRIPTION	ITEM NO.	PART NUMBER	DESCRIPTION
*	STD.6550	Entire Assembly	9.	STD.6553	Throttle Cable- direct drive
1.	STD.6551A	Mounting Base		STD.6553B	Throttle Cable- belt drive 800
2.	STD.6551A.01	Mounting Base Thick Spacer	10.	STD.6557	Throttle Actuator (bottom)
3.	STD.6511A.02	Mounting Base Thin Spacer	11.	STD.6558	Cable Adaptor- throttle
4.	STD.6566	Wiring Harness	12.	STD.6552A	Cover
5.	STD.6555	Limit Switch	13.	4045.6565	Throttle Cable Bracket
6.	STD.6554	Clutch Cable- direct drive	14.	4045.6564	Clutch Cable Bracket
	STD.6554B	Clutch Cable- belt drive 800	15.	STD.6563	Torque Coupling
7.	STD.6556	Clutch Actuator (top)	16.	STD.6562	Torque Coupling Sleeve
8.	STD.6559	Cable Adaptor- clutch	17.	STD.6560	PTO Cable Adaptor
			18.	STD.6561	Roller Bearing

Chaffe Eliminator Assembly, hinged

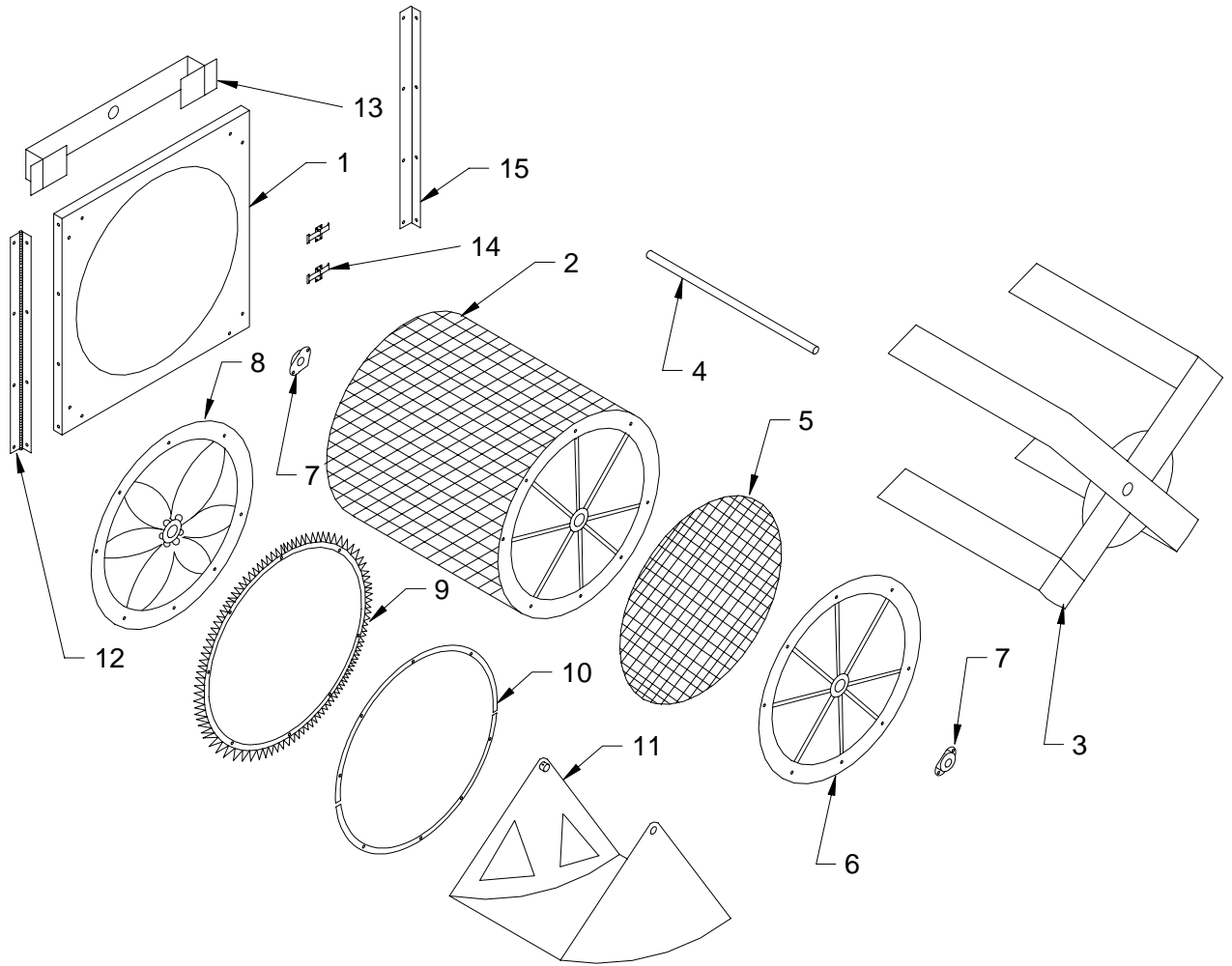

ITEM NO.	PART NUMBER	DESCRIPTION
1.	RAS.102	Base Frame
2.	RAS.103	Barrell Asssembly
3.	RAS.104	Support Frame
4.	RAS.105	Shaft
5.	RAS.106	Mesh Screen
6.	RAS.107	Screen Holder
7.	RAS.108	Flange Bearing
8.	RAS.101	Fan
9.	RAS.109	Strip Brush
10.	RAS.110	Brush Holder
11.	RAS.111	Air Deflector
12.	RAS.112	Hinge
13.	RAS.113	Shaft Bracket
14.	LCT609.602	Overcenter Latch, all but LCT650
	LCT650.114	Destaco Latch, not shown, LCT650 only
15.	RAS.114	Angle Frame, LCT650 only

Harness Wiring Kit Group

*for servicing the Circular Plastic Connectors (CPC) on ODB's wiring harnesses

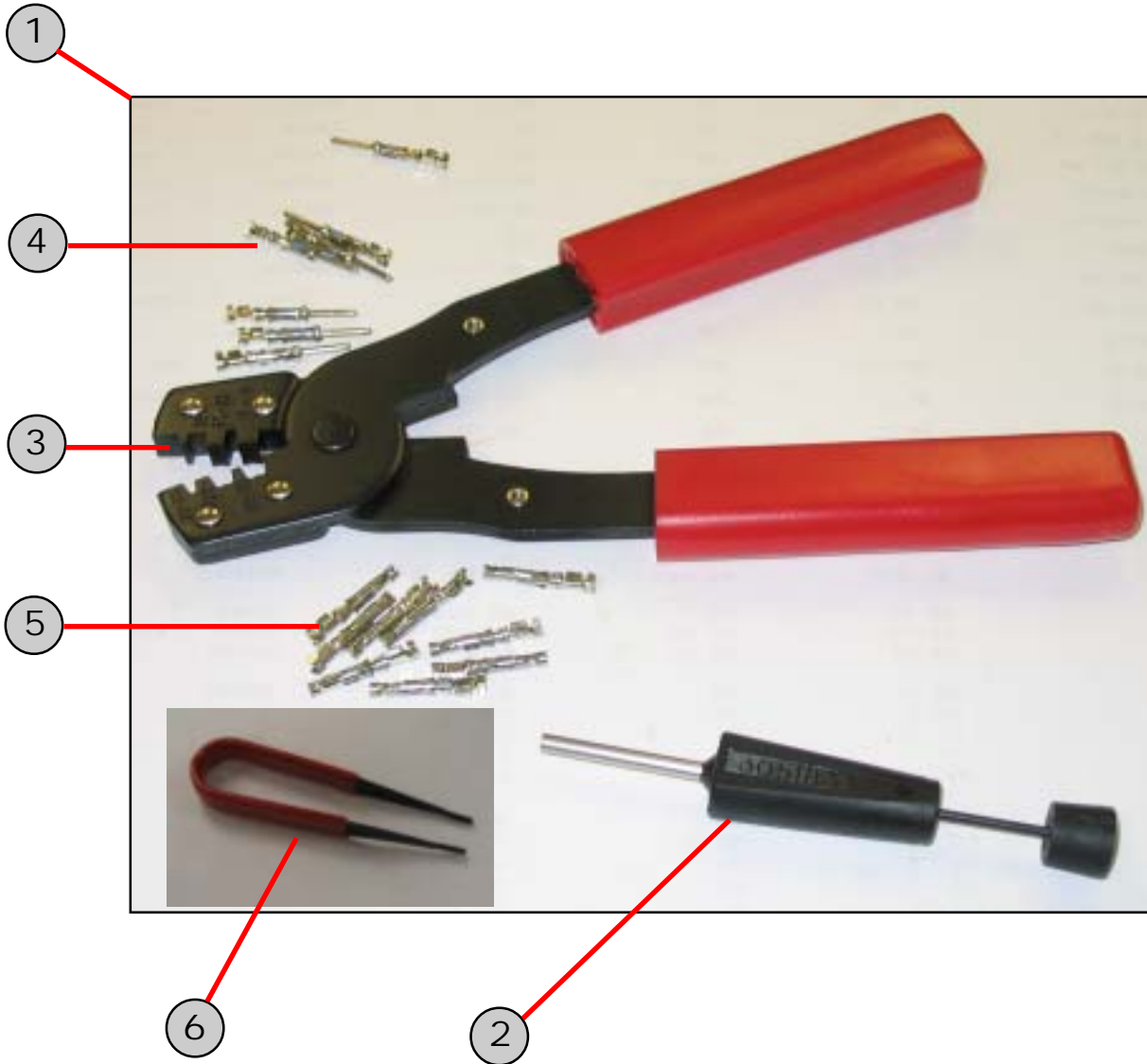

ITEM NO.	PART NUMBER	DESCRIPTION
----------	-------------	-------------

1.	STD.2900A	Crimper, Extractor Pin Kit, includes the following:
2.	STD.2903	Pin Extraction Tool
3.	STD.2901	Crimper
4.	STD.2913	Male Pins Contacts, package of 25
5.	STD.2914	Female Socket Contacts , package of 25
6.	STD.2920	Insertion Tool

Harness Connector Kit Group

*for servicing the Circular Plastic Connectors (CPC) on ODB's wiring harnesses



Engine Wiring Harness

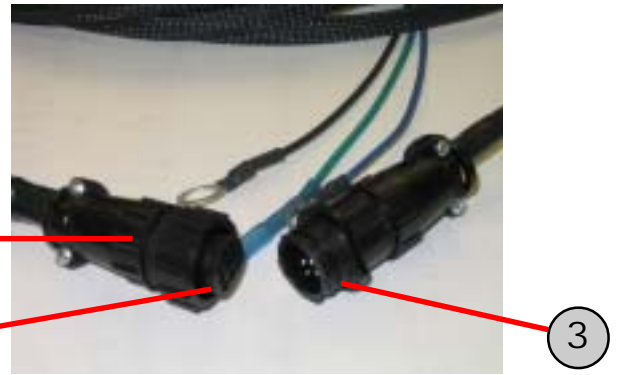

Boom Pump Wiring Harness

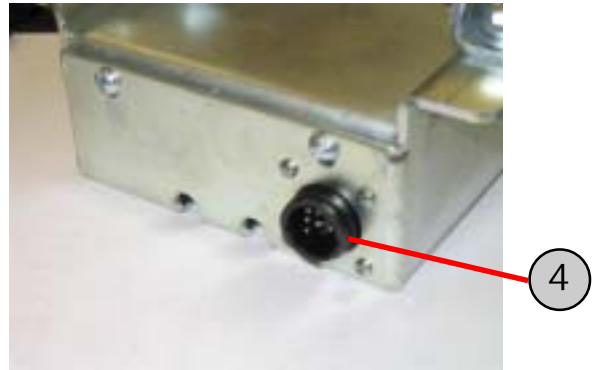
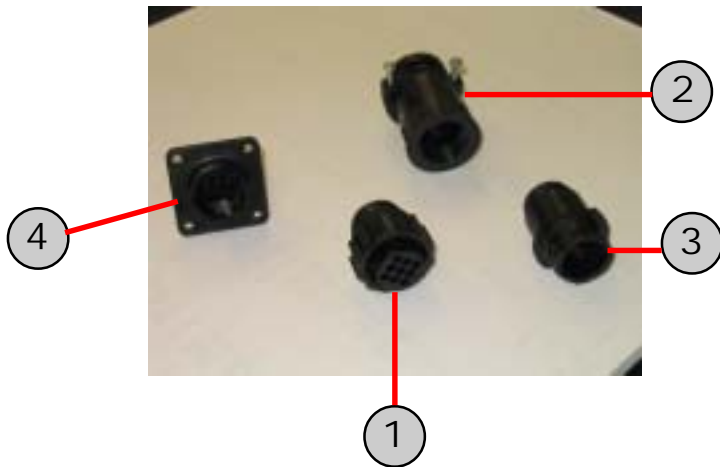

Boom Up/Down Switch Receptacle

ITEM NO.	PART NUMBER	DESCRIPTION
----------	-------------	-------------

*	STD.2900B	Kit includes 2 each of all the items below:
1.	STD.2917	Socket Plug, 9 contact
2.	STD.2916	Cable Clamp
3.	STD.2918	Pin Receptacle, free hanging, 9 pin
4.	STD.2919	Square Flange Receptacle, 9 pin

*For the pins and socket contacts please see the Harness wiring group

Engine Miscellaneous Parts Group

John Deere Engines

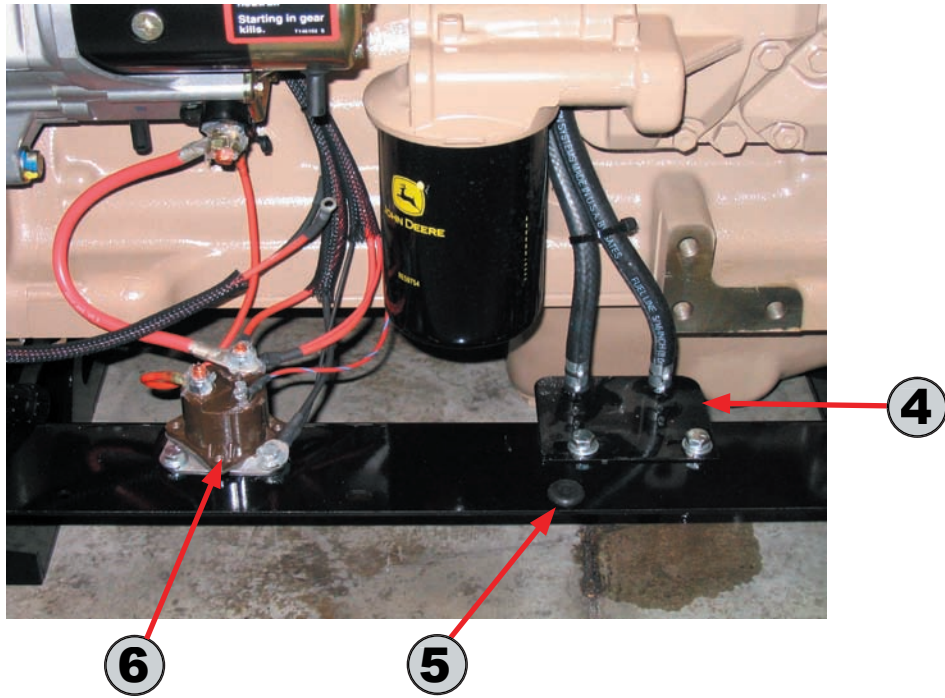
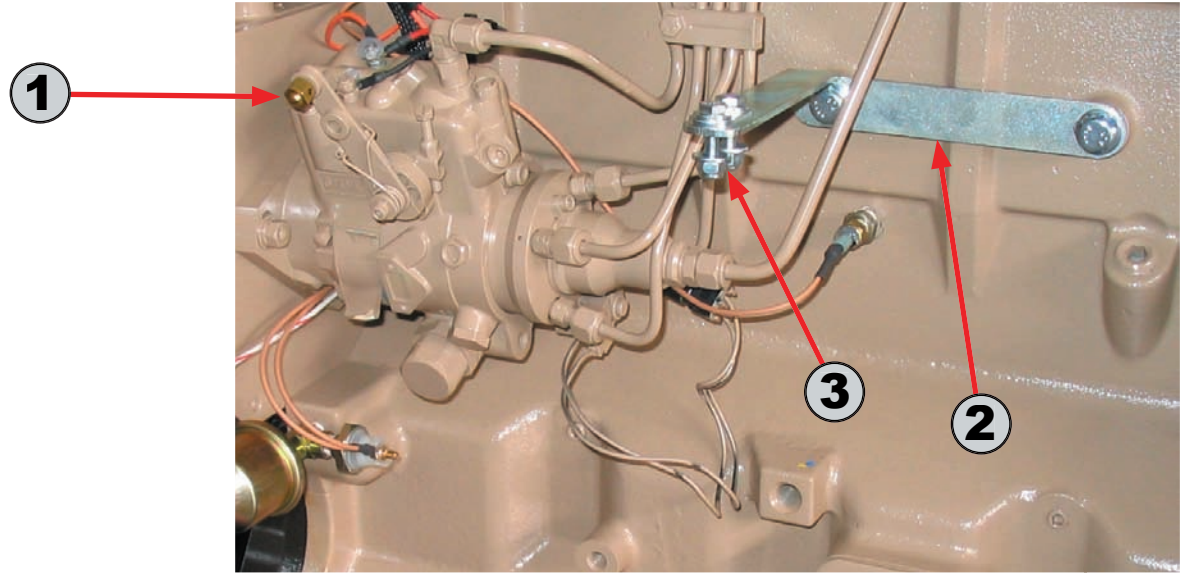

ITEM NO.	PART NUMBER	DESCRIPTION
1.	39011.2	Throttle Connector
2.	4045.9101	Throttle Cable Bracket
3.	4045.9101A	Throttle Cable Clamp
4.	400016	Fuel Line Bracket
5.	2856.26012	Grommet - Door
6.	ST40	Starter Solenoid

Battery Group

Standard units 2001 and after

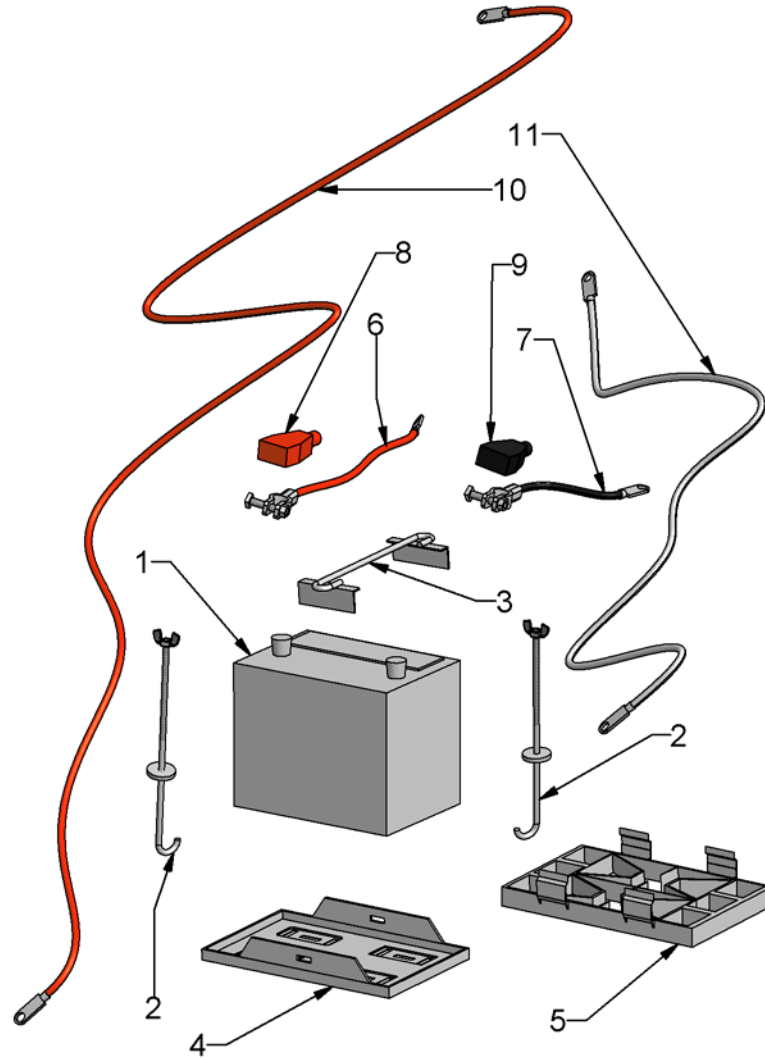

ITEM NO.	PART NUMBER	DESCRIPTION
1.	STD.2200	Battery, not shippable
2.	BHB10J	J-Hook
3.	BHCB	Battery Hold Down Bar
4.	BTS1	Battery Tray, all but SCL's
5.	BTSC	Battery Tray, SCL
6.	SCL.42B	Positive Battery Cable, Battery to Solenoid - SCL (standard)/650/60C - 42" long
	LCT600.84B	Positive Battery Cable, Battery to Solenoid - SCL (Belt-Drive)/LCT600/6000 - 84" long
7.	LCT60.15B	Negative Battery Cable, all - 15" long
8.	BTC.R	Terminal Cover, Red, all
9.	BTC	Terminal Cover, Black, all
10.	LCT600.72SS	Red Cable to Hydraulic Boom Pump, SCL/600/6000 - 72" long
	MET.60SS	Red Cable to Hydraulic Boom Pump, LCT650 - 60" long
	LCT60C.153SS	Red Cable to Hydraulic Boom Pump, LCT60C - 153" long
11.	LCT600.24SS	Ground (Black) Cable to Chassis, 600/6000/60C - 24"



CLUTCH GROUP

- *Clutch Breakdown
- *Auto PTO Breakdown
- *Auto PTO Linkage
- *Clutch Assist Breakdown

CLUTCH GROUP

ODB COMPANY

5118 Glen Alden Drive
Richmond, VA 23231

800-446-9823

Auto PTO Clutch Group

After October 2000

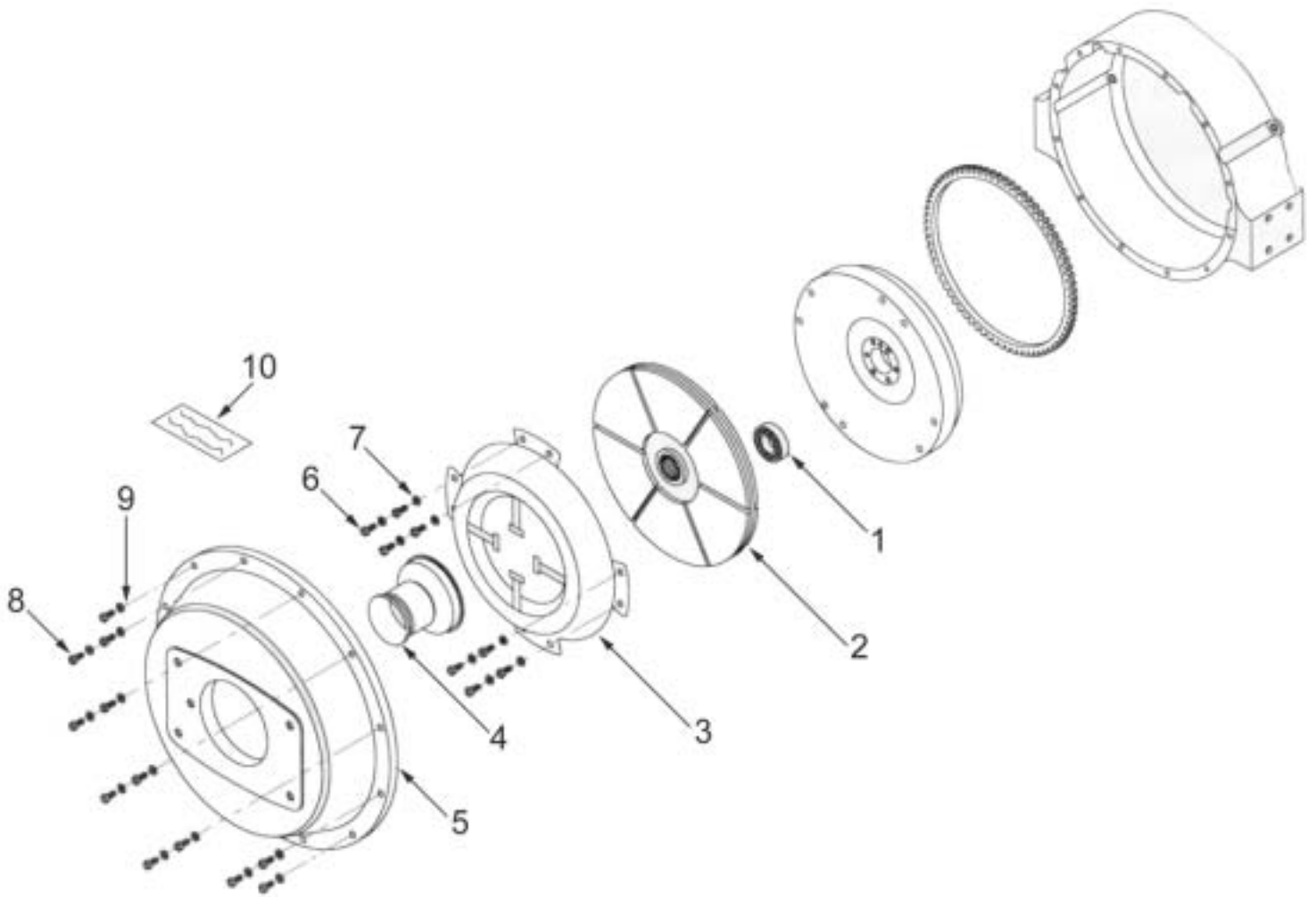

ITEM NO.	PART NUMBER	DESCRIPTION
*	OD-48080023	*Complete PTO and Clutch Assembly
1.	OD-6305.2RS	Pilot Bearing
2.	OD-41500061	Clutch Disk
3.	OD-41500060	Pressure Plate
4.	OD-41500003	Throw out Bearing
5.	OD-41500006	Clutch Cover
6.	OD-45000054	Bolt, 3/18-16 x 3/4"
7.	OD-45000063	Lock Washer, 3/8"
8.	OD-45000043	Bolt, M10-150 x 30 MM
9.	OD-45000046	Lock Washer, M10
10.	OD-41500009	Decal, Diesel Clutch

Note: *4800023 includes items 1 -10 above , 41500137 PTO Assembly on the previous page and the complete linkage assembly located on the linkage page. This is the complete PTO/Clutch assembly. It does not include the clutch assist assembly.

Auto PTO Assembly Group

After October 2000

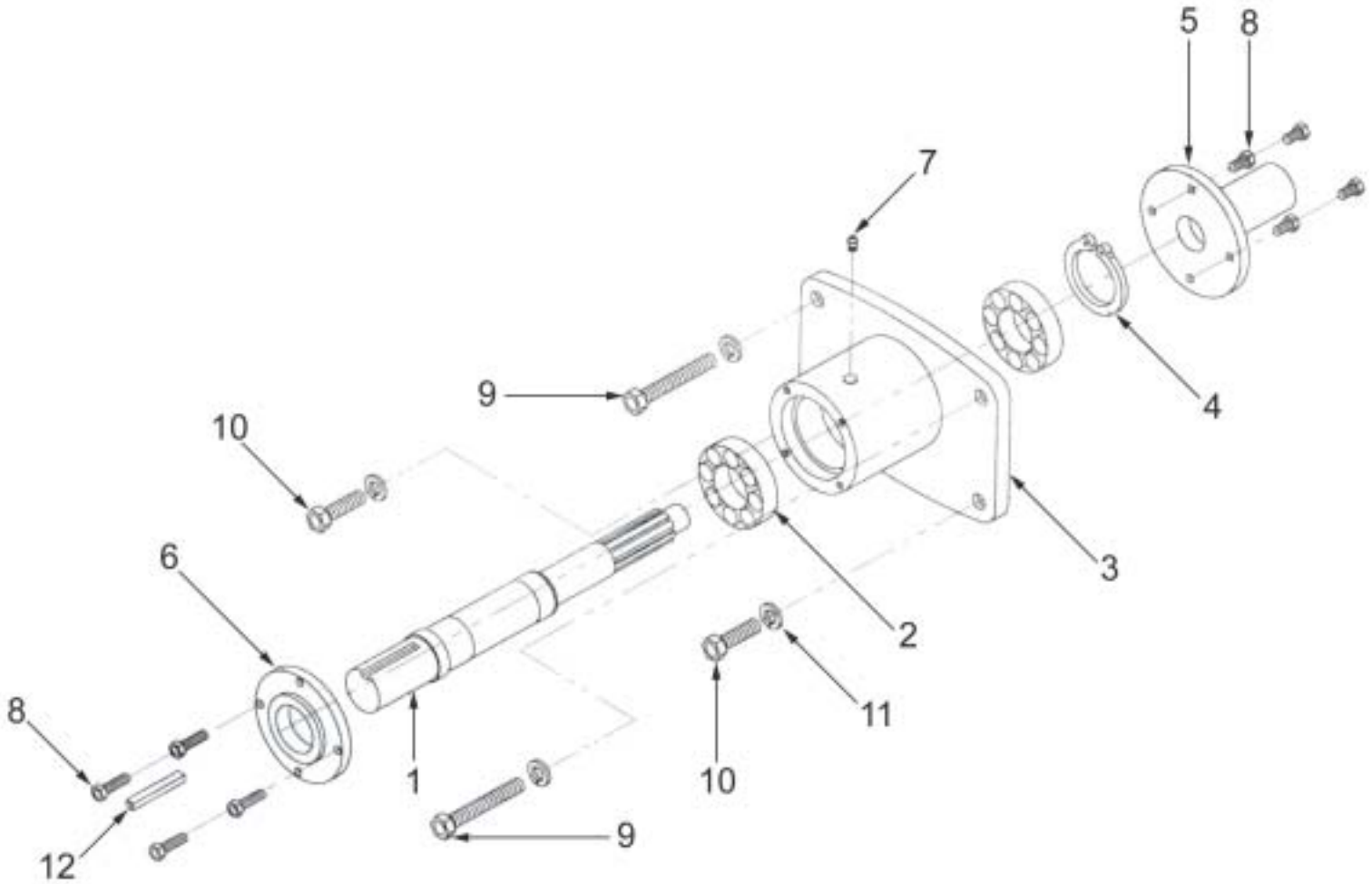

ITEM NO.	PART NUMBER	DESCRIPTION
*	OD-41500137	Complete PTO Assembly (items 1 -11)
**	OD-48080023	**Complete PTO & Clutch Assembly
1.	OD-41500053	PTO shaft
2.	OD-41500054	PTO Bearing
3.	OD-41500055	PTO Housing
4.	OD-41500056	Snap Ring, 1 11/16"
5.	OD-45000000	PTO Collar
6.	OD-41500057	Bearing Retainer Cover
7.	OD-41500058	Grease Zerk
8.	OD-45000029	Bolt, 5/16-18 x 3/4"
9.	OD-45000105	Bolt, 9/16-12 x 3"
10.	OD-45000104	Bolt, 9/16-12 x 1 1/2"
11.	OD-45000103	Lock Washer, 9/16"
12.	OD-LCT650.601K	Key, Stepdown--direct drive units only
12.	OD-LCT650.601F	Key, belt drive units only

**OD-48080023 includes 41500137, the complete clutch assembly on the next page and the complete linkage assembly on the linkage page.

Auto PTO Linkage Group

After October 2000

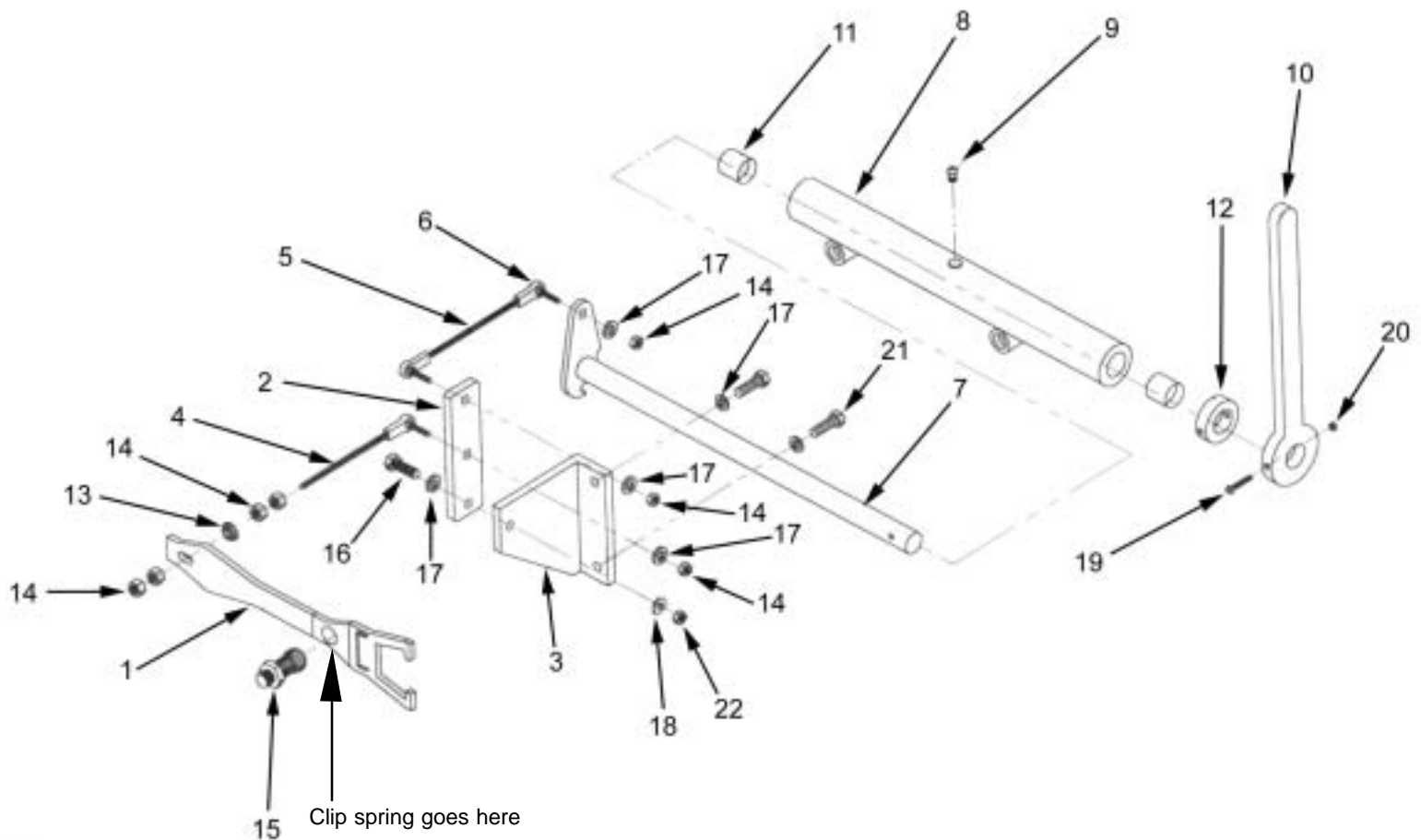

ITEM NO.	PART NUMBER	DESCRIPTION	ITEM NO.	PART NUMBER	DESCRIPTION
1.	41500063	Fork	12.	41500046	Shaft Collar
NS	41500174	Clip Spring in Fork	13.	41500030	Rocker Ball
NS	41500999	Return Spring	14.	45000050	Nut, 3/8 - 16
2.	41500027	Linkage Bracket	15.	41500001	Pivot Ball
3.	41500026	Linkage Bracket	16.	15000177	Bolt, 3/8 - 16 x 1 3/4"
4.	41500067	Linkage Rod	17.	45000063	Lock Washer, 3/8"
5.	41500066	Linkage Rod	18.	45000064	Flat Washer, 3/8"
6.	41500019	Linkage Rod End	19.	45000012	Bolt, 1/4 - 28 x 2"
7.	41500041	Shaft, Lever	20.	45000015	Locknut, 1/4 - 28
8.	41500042	Shaft Housing	21.	45000055	Bolt, 3/8 - 16 x 1 1/4"
9.	41500043	Grease Zerk	22.	45000051	Locknut, 3/8 - 16
10.	41500044	Clutch Handle	23.	41500002	Assembly, PTO Lever
11.	41500045	Shaft Bushing			

Clutch Assist Group

Auto PTO- John Deere 4045D (11/00 -)

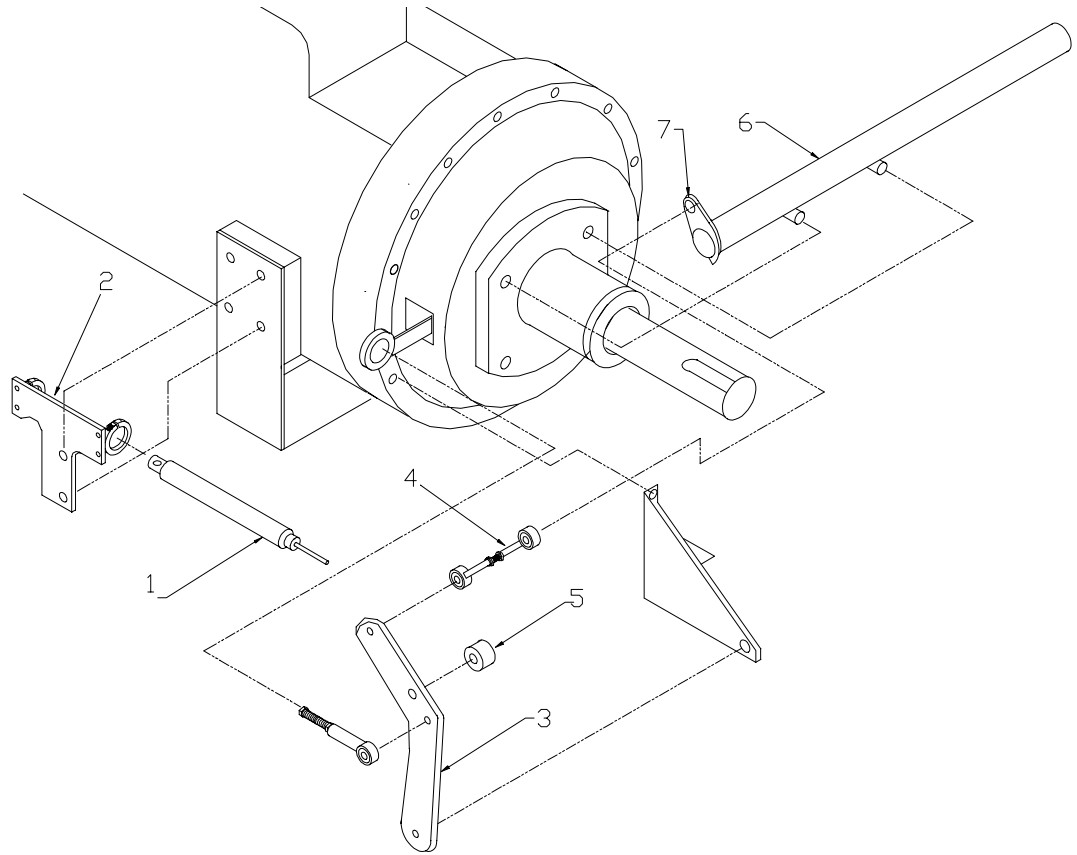

ITEM NO.	PART NUMBER	DESCRIPTION
1.	400050.A	Clutch Cylinder
2.	400054.C	Cylinder Support Bracket
3.	400054.A	Clutch Bracket Arm
4.	41500019	Linkage, Rod end
	41500019A	Linkage, Threaded insert
5.	400050.C1	Bearing
6.	41500042	Pivot Shaft Tube
7.	41500041	Pivot Shaft, LCT600
	41500041A	Pivot Shaft, SCL800 & LCT60C
	41500041B	Pivot Shaft, LCT650



BLOWER HOUSING GROUP

- *Impeller & Blower Breakdown
- *Blower Housing Face Assembly
- *Belt Drive Assembly
- *Pedestal & Bearing Assembly
- *Exhaust Duct Assembly

BLOWER HOUSING GROUP

ODB COMPANY

5118 Glen Alden Drive
Richmond, VA 23231

800-446-9823

LCT600/6000 Blower Group

After February 1999

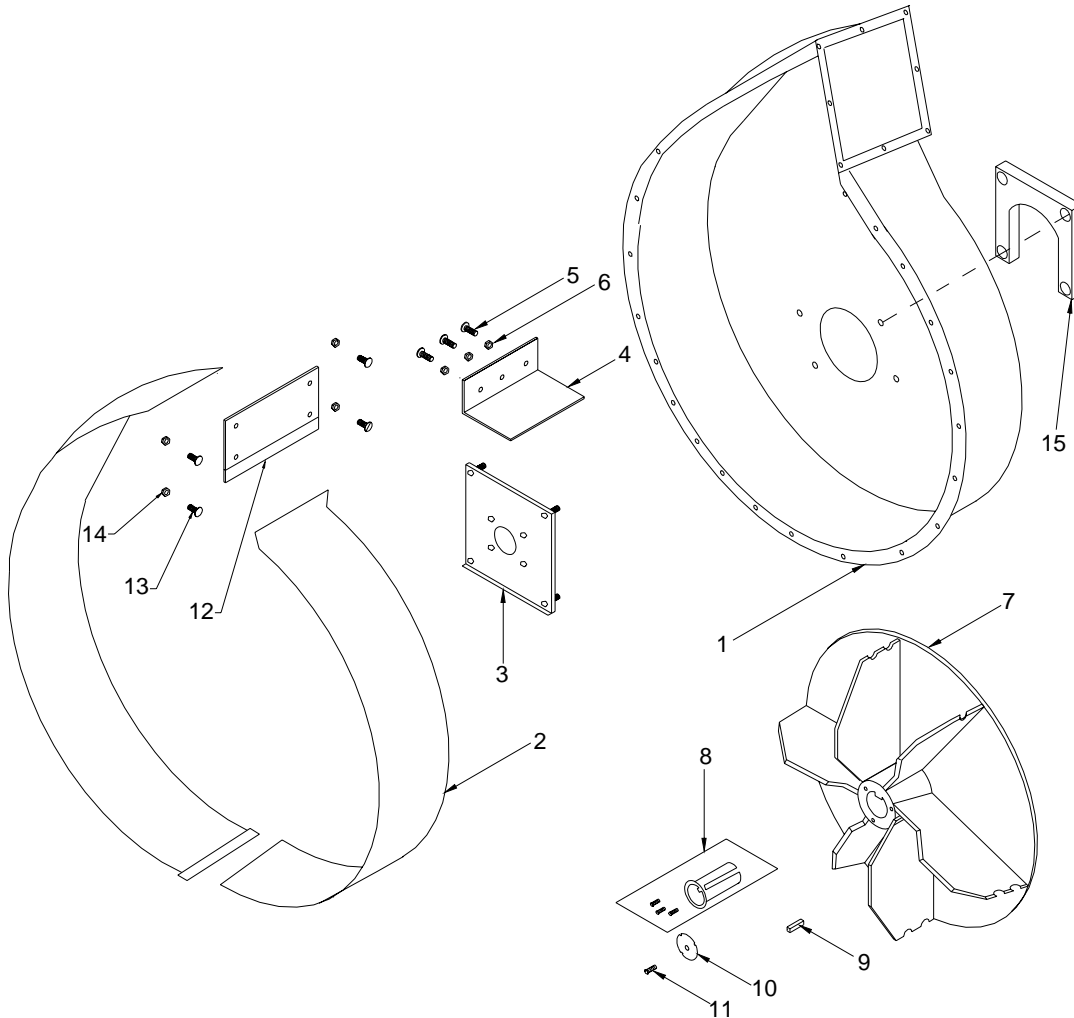

V2.2

ITEM NO.	LCT600 PART NUMBER	LCT6000 PART NUMBER	DESCRIPTION
1.	LCT620.601	LCT630.601	Blower Housing Back
2.	LCT620.602	LCT630.602	Liner Set
3.	LCT600.602	LCT630.104	Inner Bearing Plate, thru March 2002
	LCT600.603	LCT630.104A	Inner Bearing Plate, after March 2002
4.	LCT620.602A	LCT630.602A	Bolt-In Wrap around Liner
5.	LCT620.603	LCT620.603	Flat Head Bolt
6.	LCT620.603N	LCT620.603N	Nut
7.	LCT600.33	LCT6000.38	Impeller
8.	LCR650.601	LCT630.101	Impeller Bushing
9.	LCT650.601F	LCT650.601F	Bushing Key
10.	LCT600.615	LCT630.102	Shaft Protector
11.	5CZ.500.750	5CZ.500.750	Shaft Bolt
12.	LCT620.604	LCT630.603	Liner, straight, after 03/02
13.	LCT620.605	LCT620.605	Bolt, after 03/02
14.	LCT620.605N	LCT620.605N	Nut, after 03/02
15.	LCT650.602.D*	LCT630.109.D*	Spacer for Bearing, 2003 and after

*must use LCT600.603 (600) or LCT630.104A (6000)- item#3

Blower Housing Face Group - LCT600/6000

Single Axis units after September 1996

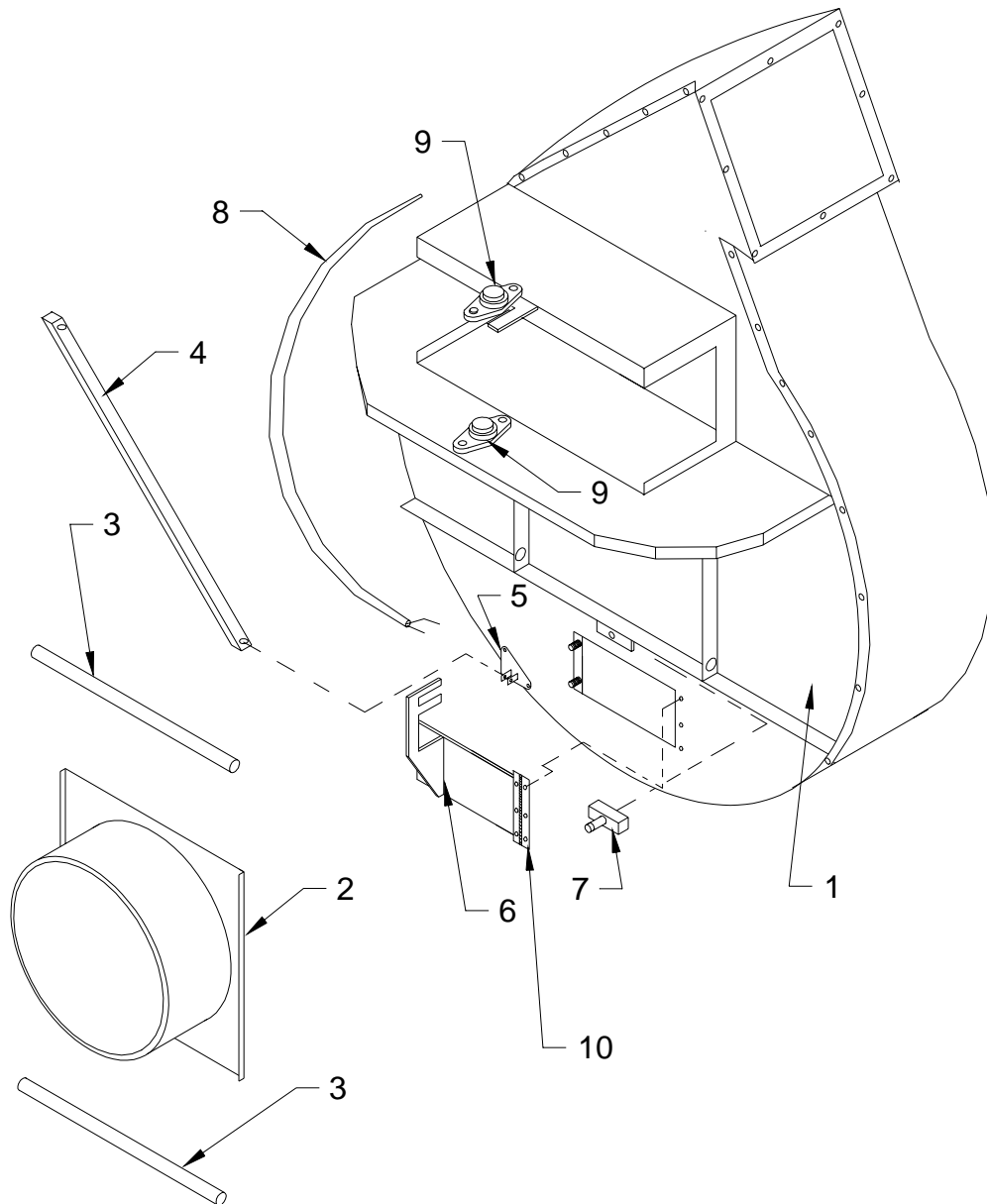

ITEM NO.	PART NUMBER	DESCRIPTION
1.	LCT621.601FB LCT630.601FB	Blower Housing Face, LCT600 Blower Housing Face, LCT6000
2.	LCT616.604 LCT616.604.18	Intake Flange, LCT600 Intake Flange, LCT6000
3.	LCT600.635.1	Lock Rod
4.	LCT621.590	Support Bar
5.	LCT621.591	Support Bar Bracket
6.	SCL621.602	Inspection Door
7.	LCT690.601.A	Limit Switch
8.	LCT690.602	Limit Switch Wire
9.	LCT616.801	Boom Bearing
10.	LCT621.603	Inspection Door Hinge

LCT600 Pedestal Group

After February 1999

V3.0

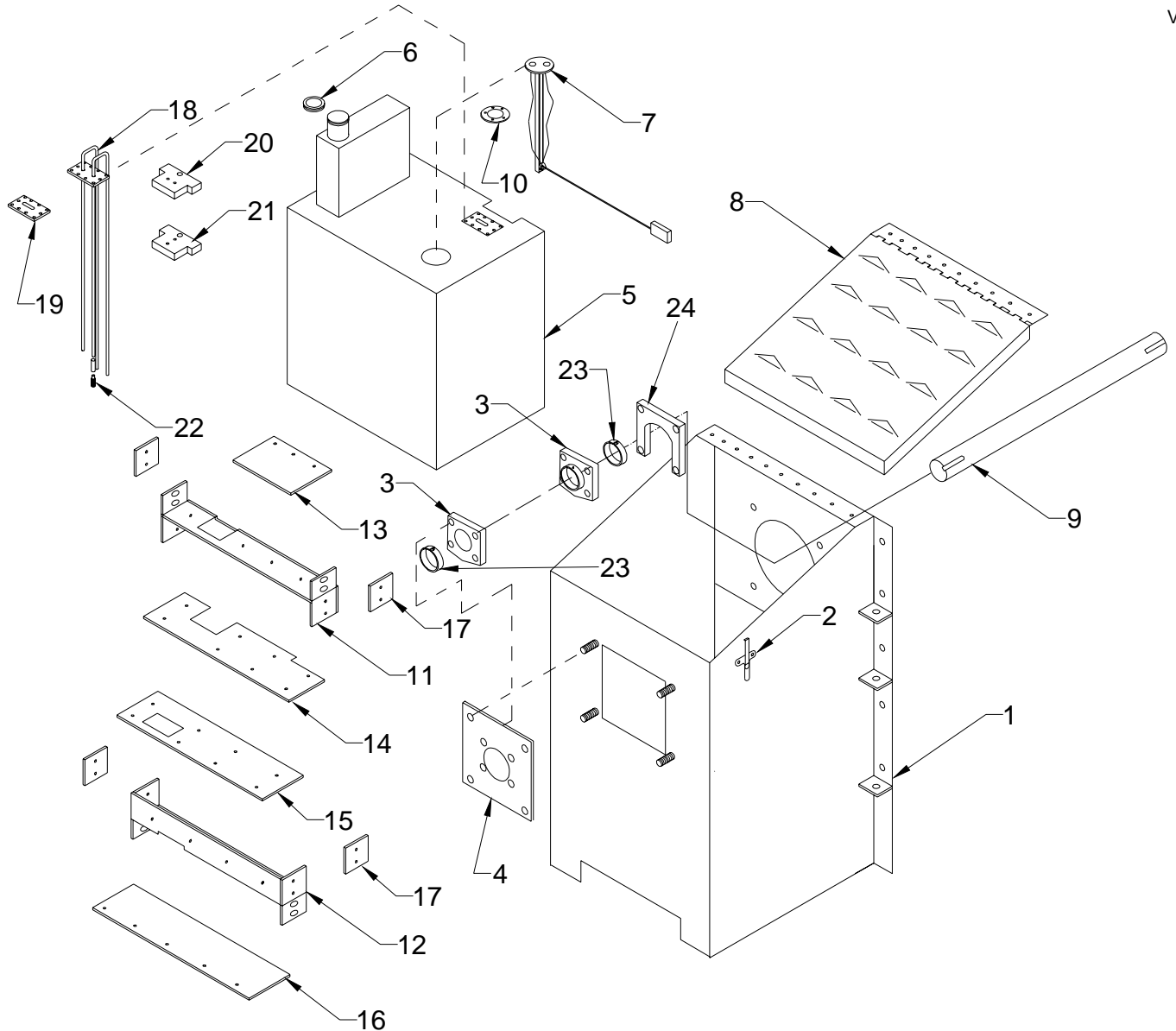

ITEM NO.	PART NUMBER	DESCRIPTION	ITEM NO.	PART NUMBER	DESCRIPTION
1.	LCT609.601P	Pedestal	12.	LCT633.608	Lower Fuel Tank Bracket
2.	LCT609.602	Overcenter Latch	13.	LCT633.614	Pedestal Rubber, Top
3.	LCT650.602.A	Flange Bearing, 2 1/4"	14.	LCT633.610	Fuel Tank Brkt Rubber, Top
4.	LCT600.610	Outer Bearing Plate, -03/02	15.	LCT633.609	Fuel Tank Brkt Rubber, Bottom
	LCT600.611	Outer Bearing Plate, 04/02-	16.	LCT633.65	Pedestal Rubber, Bottom
5.	LCT633.601P	Fuel Tank, Plastic	17.	LCT633.618	Fuel Tank Brkt Side Rubber
6.	LCT633.605P.1	Fuel Cap	18.	LCT633.611	Fuel Pickup Tubes
7.	87424	Fuel Sender	19.	LCT633.612	Gasket
8.	LCT614.601	Pedestal Lid	20.	LCT633.619A	Tube Spacer, upper
9.	LCT650.0	Shaft, 2 1/4"D; 29 1/2" Long	21.	LCT633.619B	Tube Spacer, lower
10.	87424G	Gasket for Fuel Sender	22.	LCT633.617	Fuel Strainer
11.	LCT633.607	Upper Fuel Tank Bracket	23.	LCT650.602.C*	Lock Collar, bearings
			24.	LCT650.602.D*	Spacer, 2003 and after

*Can only be used with the LCT600.603 Inner Bearing Plate

Exhaust Duct Assembly

LCT600/6000

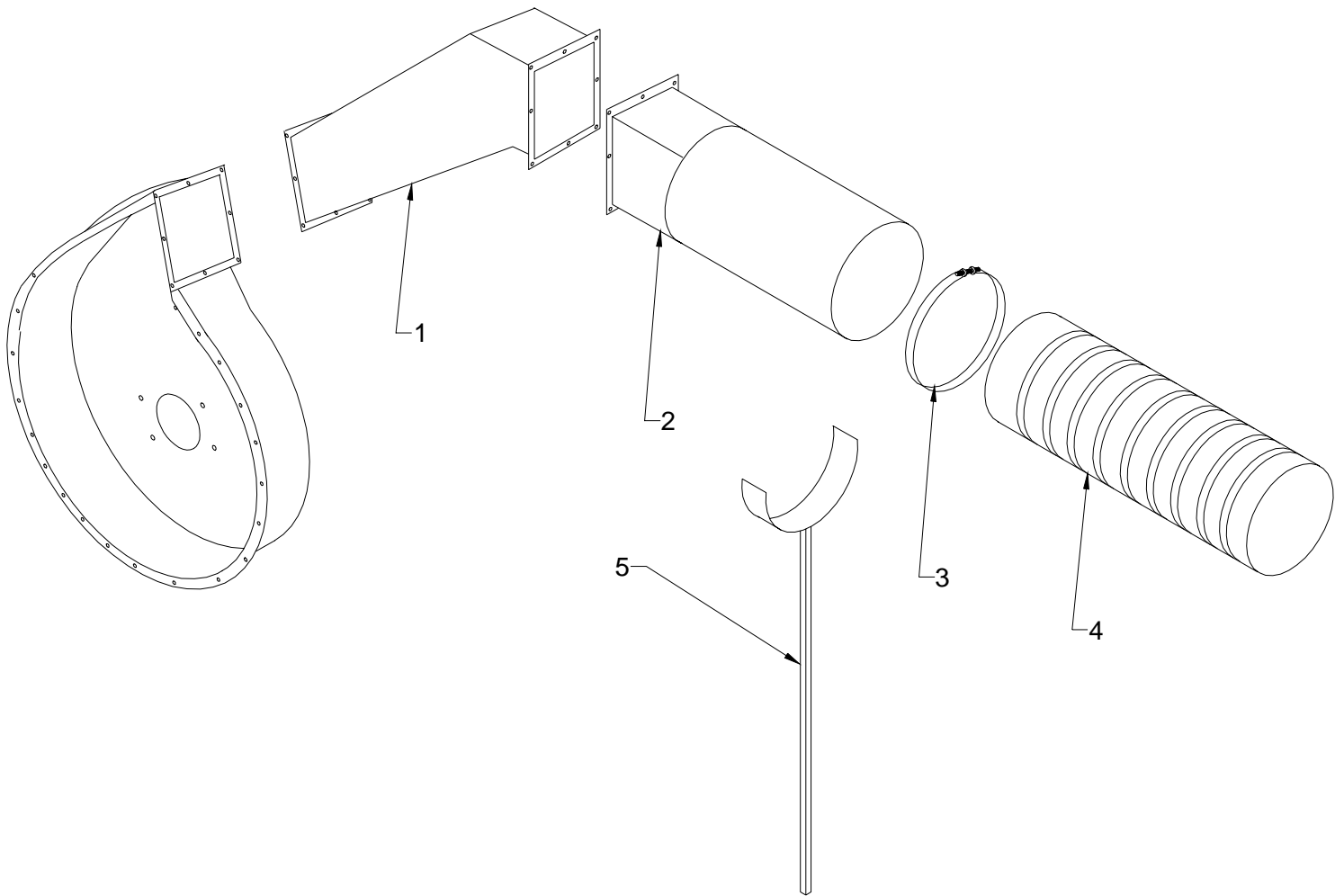

ITEM NO.	LCT600	LCT6000	DESCRIPTION
	PART NUMBER	PART NUMBER	
1.	LCT621.610	LCT631.610	Discharge Duct
2.	LCT621.611A	LCT631.611	Transition
3.	LCT616.616	LCT616.618	Hose Band
4.	LC-MDH.16.48	LC-MDH.18.60	Exhaust Hose
5.	LCT60.629	LCT60.629B	Exh. Hose Support



TRAILER GROUP

- *Trailer Bed Assembly
- *Tongue Assembly
- *Axle Hub Assembly
- *Electric Brake Assembly

TRAILER GROUP

ODB COMPANY

5118 Glen Alden Drive
Richmond, VA 23231

800-446-9823

Trailer Bed Group

LCT600 and LCT6000 after 09/04

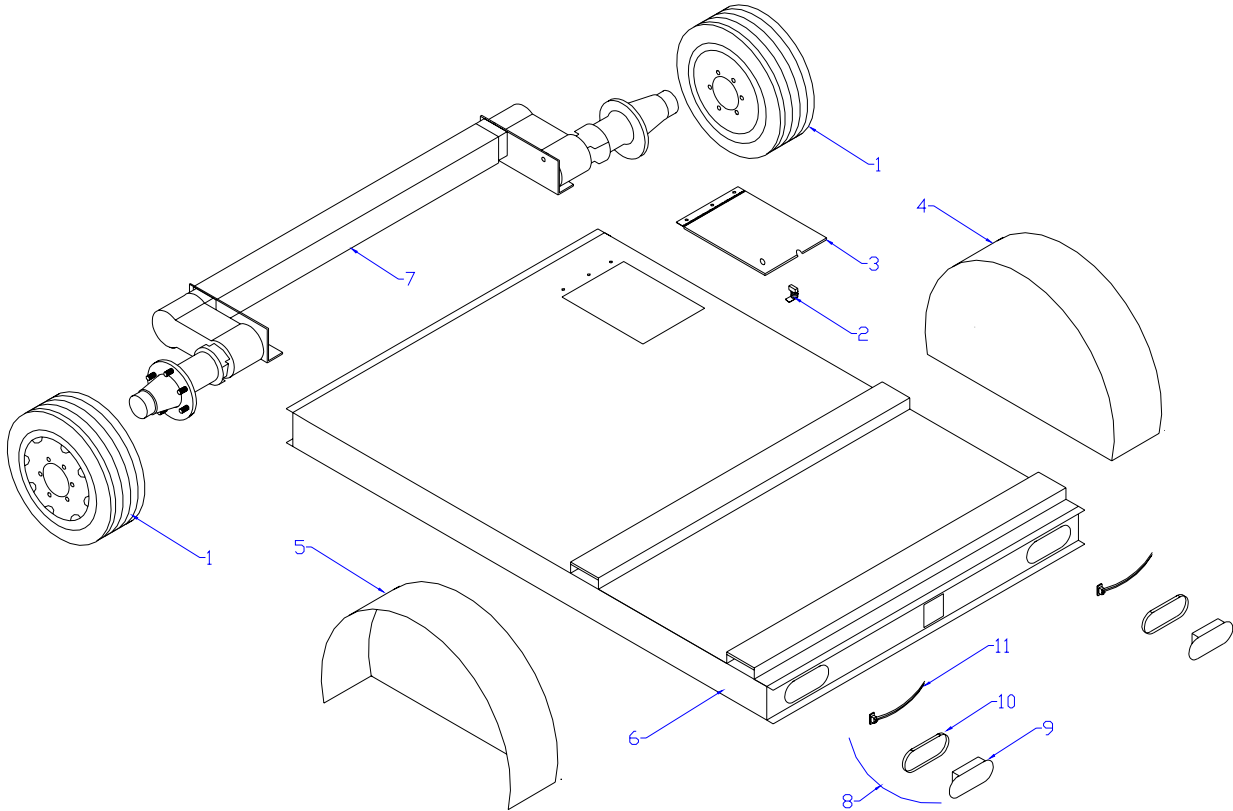

ITEM NUMBER	PART NUMBER	DESCRIPTION
1.	LCT622.619	Tire and Rim Assembly
	Consists of:	
	LCT622.619T	Tire only
	LCT622.619R	Rim only
2.	LCT622.602.L	Battery Box Latch
3.	LCT622.602	Battery Box Door
4.	LCT613.601B	Fender, RH
5.	LCT613.602B	Fender, LH
6.	LCT622.601.99	Trailer Bed, LCT600, thru 03/01
	LCT622.601.01	Trailer Bed, LCT600, 04/01 and after
	LCT631.630	Trailer Bed, LCT6000, thru 03/01
	LCT631.630.01	Trailer Bed, LCT6000, 04/01 and after
7.	LCT622.614T	Axle Assembly, LCT600, thru 03/00
	LCT622.614TE	Axle Assembly, LCT600, 04/00 and after
	OD-6000.11	Axle Assembly, LCT6000
8.	LCT622.613	Tail Light Assembly through 09/04
	STD.2505	Tail Light Assembly after 09/04
9.	OD-60201R	Sealed housing assembly with bulb
10.	OD-60700	Grommett
11.	OD-94992	Right angle Plug

TONGUE GROUP

LCT60C, LCT600, LCT650 and LCT6000

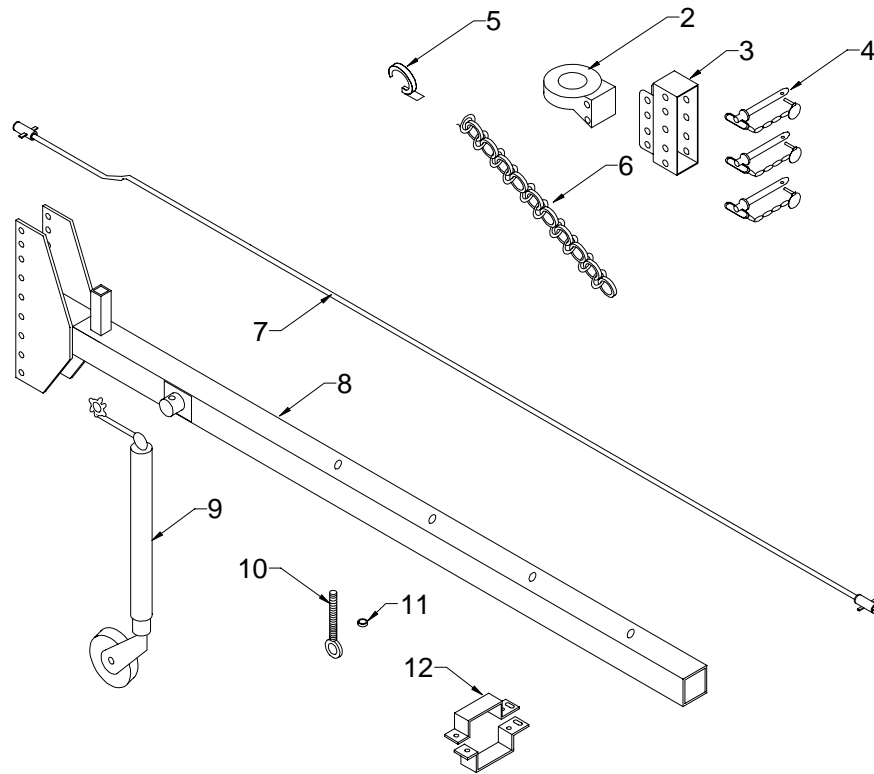

ITEM NUMBER	PART NUMBER	DESCRIPTION
1.	LCT622.623A	Pintle Eye Assembly (thru 02/01)
	LCT622.623D	Pintle Eye Assembly (03/01 and after)
	Consists of:	
2.	LCT622.623	Pintle Eye Ring
3.	LCT622.623A.1	Bracket with U channel (thru 02/01)
	LCT622.623A.2	Bracket with U channel (03/01 and after)
4.	200012	Pintle Eye Pins
5.	200009.3	Safety Hook
6.	LCT622.625	Safety Chain
7.	LCT622.626	Power Cord
8.	LCT622.622	Tow Bar, all LCT's thru 02/01
	LCT622.633	Tow Bar, LCT60C & LCT650 03/01 and after; 8' long
	LCT622.634	Tow Bar, LCT600 03/01 and after, 10' long
	LCT622.636	Tow Bar, LCT6000 03/01 and after, 10' long
9.	LCT622.624	Parking Jack
10.	LCT622.622I	Eyebolt, used thru 02/01
11.	LCT622.622W	Eyebolt washer, used thru 02/01
12.	LCT622.635	Hose lock bracket, thru 02/01
	LCT622.635A	Hose lock bracket- LCT600, after 03/01
	LCT622.635B	Hose lock bracket- LCT6000, after 03/01

Axle Hub Assembly

LCT60C/600/650/6000

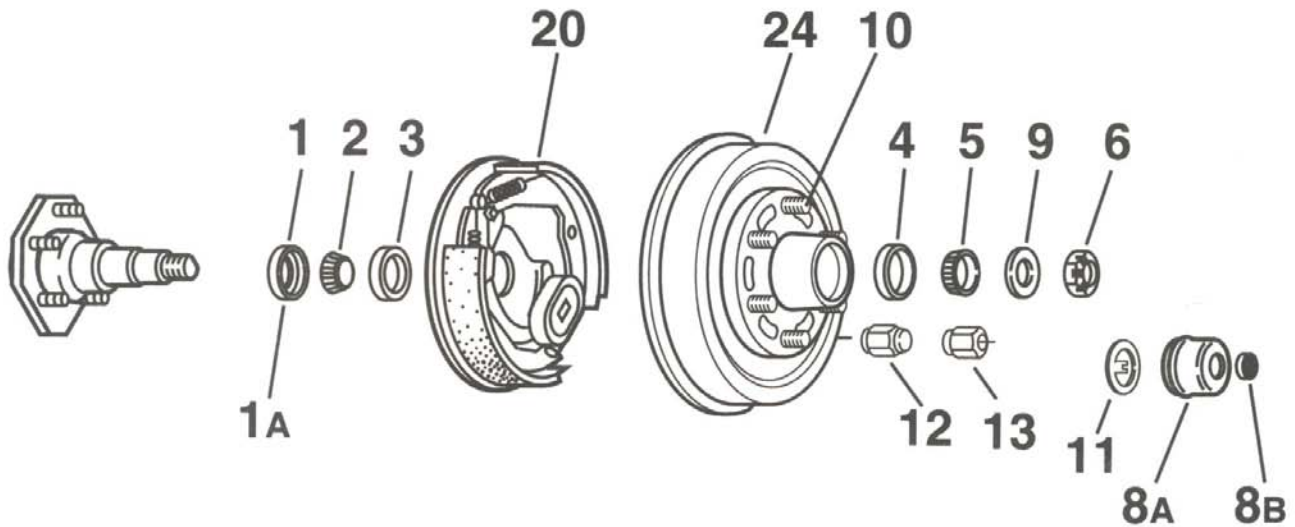

ITEM NO.	PART NUMBER	DESCRIPTION
1.	10.10	Grease Seal
2.	31.30.2	Inner Bearing Cone
3.	31.30.1	Inner Bearing Cup
4.	31.32.1	Outer Bearing Cup
5.	31.32.2	Outer Bearing Cone
6.	006.001.00	Spindle Nut
7.	N/A	N/A
8A.	021.042.01	Grease Cap
8B.	085.001.00	Rubber Plug
9.	005.023.00	Spindle Washer
10.	7.122	Wheel Stud
11.	005.101.00	Tang Washer
12.	006.080.00	Lug Nut
20.	23.105	Electric Brake Assembly LH
	23.106	Electric Brake Assembly RH
		(See Brake section for a breakdown)
24.	008.201.05	Grease Hub and Drum

Brake Assembly

LCT60C/600/650/6000

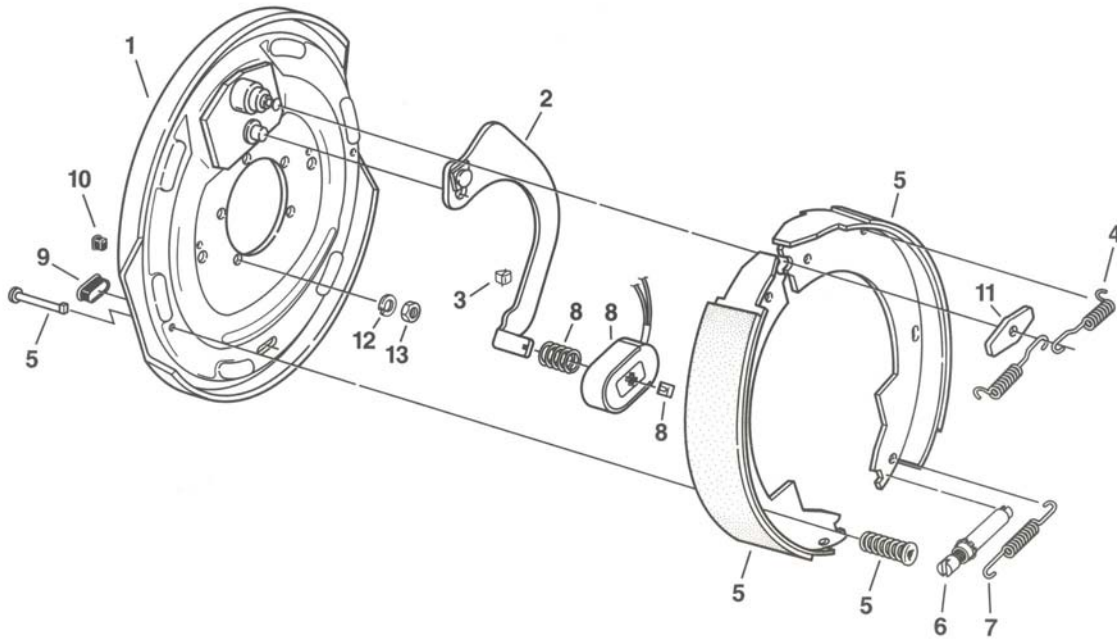

ITEM NO.	PART NUMBER	DESCRIPTION
0.	023.105.00	LH Complete Brake Assembly
0.	023.106.00	RH Complete Brake Assembly
1.	036.089.05	Backing Plate Assembly
2.	047.107.00	Actuating Lever Arm Assembly LH
	047.108.00	Actuating Lever Arm Assembly RH
3.	027.005.00	Wire Clip
4.	046.009.00	Retractor Spring
5.	K71.048.00	Shoe and Lining Kit
6.	043.004.00	Adjuster Assembly
7.	046.018.00	Adjusting Screw Spring
8.	K71.105.00	Magnet Kit containing:
	042.099.01	(1) Magnet
	027.099.00	(1) Magnet Clip
	046.080.00	(1) Magnet Spring
9.	046.007.00	Plug
10.	046.016.00	Wire Grommet
11.	005.067.00	Anchor Post Washer
12.	005.004.00	Lockwasher
13.	006.010.00	Brake Mounting Nut



HOSE BOOM GROUP

- *Hose Boom Assembly
- *Intake Hose Assembly
- *Hydraulic Pump Assembly

HOSE BOOM GROUP

ODB COMPANY

5118 Glen Alden Drive
Richmond, VA 23231

800-446-9823

LCT600/6000 Boom Group

July 2002 and after

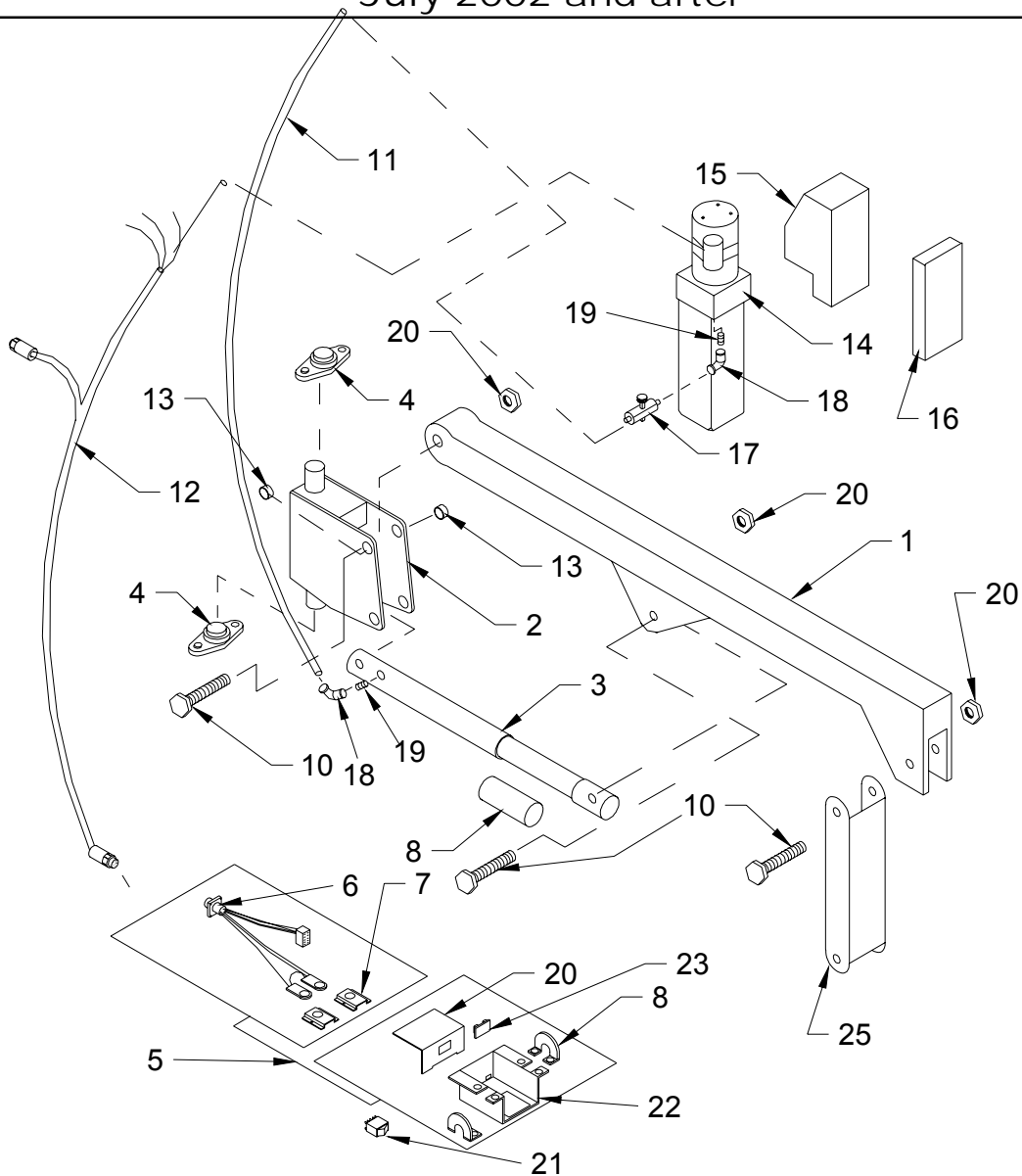

ITEM NO.	PART NUMBER	DESCRIPTION	ITEM NO.	PART NUMBER	DESCRIPTION
1.	LCT616.606A	Boom Arm	13.	RMB531	Brass Bushing
2.	LCT616.605A	Boom Mast	14.	MP-M259	Hydraulic Pump
3.	MP-CS.150.12	Boom Cylinder	15.	OD-259PC	Pump Cover
4.	LCT616.801	Boom Mast Bearings	16.	OD-200022	Pump Spacer
5.	STD.2320	Up/Down Switch Assembly	17.	LCT617.604	Flow Control Valve
6.	STD.2321	Wiring Harness	18.	OD-9405.4.4	90 degree fitting
7.	STD.2322	SS Button Hold Down	19.	OD-9205.4.4	Straight Fitting
8.	LCT617.602	Cylinder Sleeve	20.	OD-ZESNC.625	Nut
9.	LCT616.615D	Hold Down Bracket	21.	4045.0021A	Rocker Switch
10.	OD-5CZ.625.4.0	Bolt, 5/8" x 4"	22.	STD.2320	Push Button Box
11.	LCT617.608	Hydraulic Hose, 64"	23.	STD.2320D	Push Button Cover
12.	600.2322	Power Cord	24.	STD.2323	Cover Plate
			25.	LCT616.607	Hose Support Bar

Intake Hose Group

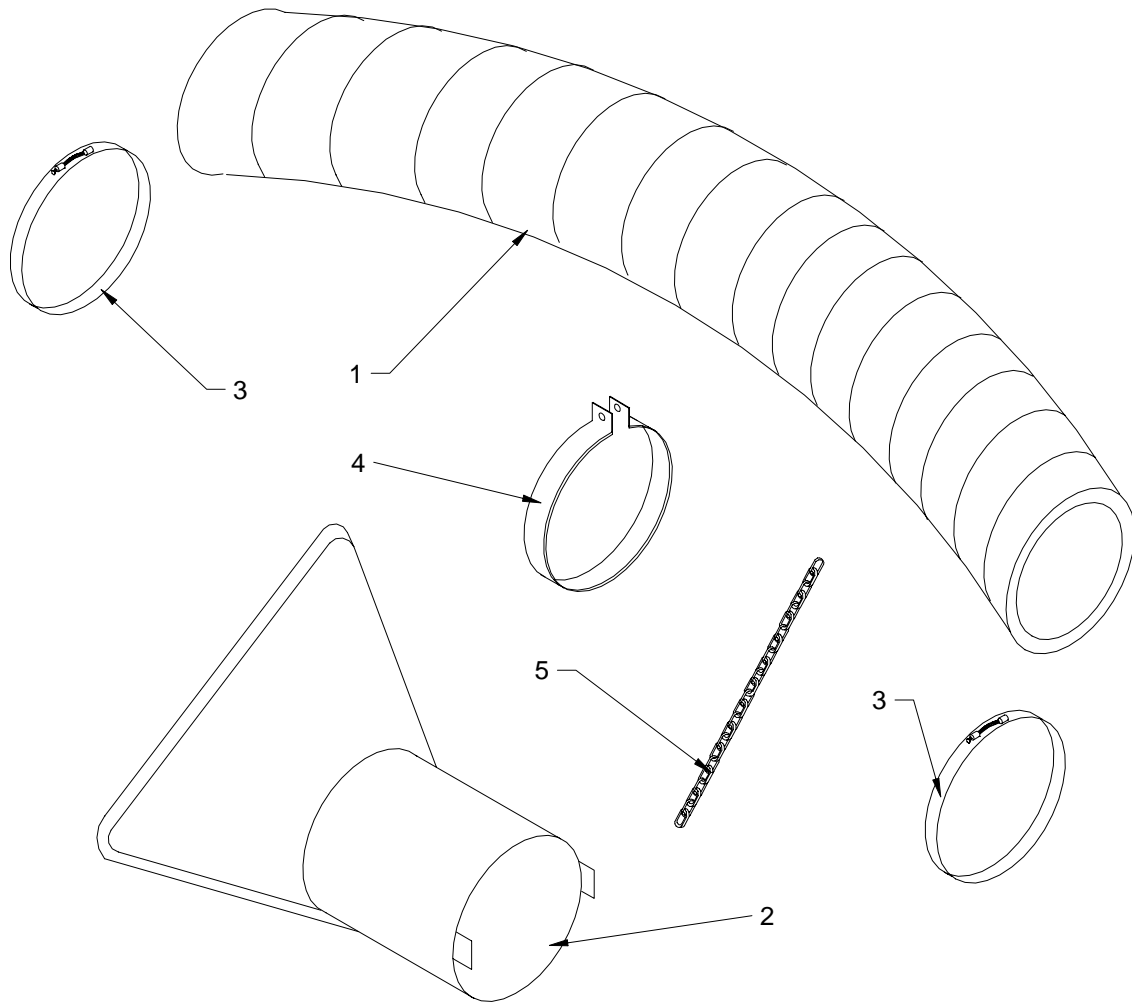

ITEM NO.	PART NUMBER (LCT60C, LCT600, LCT650, SCL800TM)	PART NUMBER (LCT6000)	DESCRIPTION
1.	LC-MDH.16.120 LC-MDH.16.100	LC-MDH.18.120	Intake Hose, except SCL Intake Hose, SCL800
2.	LCT616.601	LCT616.601.18	Intake Nozzle
3.	LCT616.616 LCT60.645	LCT616.618 LCT60.645.18	Hose Clamp, Bolt Style Hose Clamp, Quick Release (not shown)
4.	LCT616.603U	LCT616.603U.18	Hose Support
5.	LCT60.642	LCT60.642	Support Chain

M259 Hydraulic Boom Pump

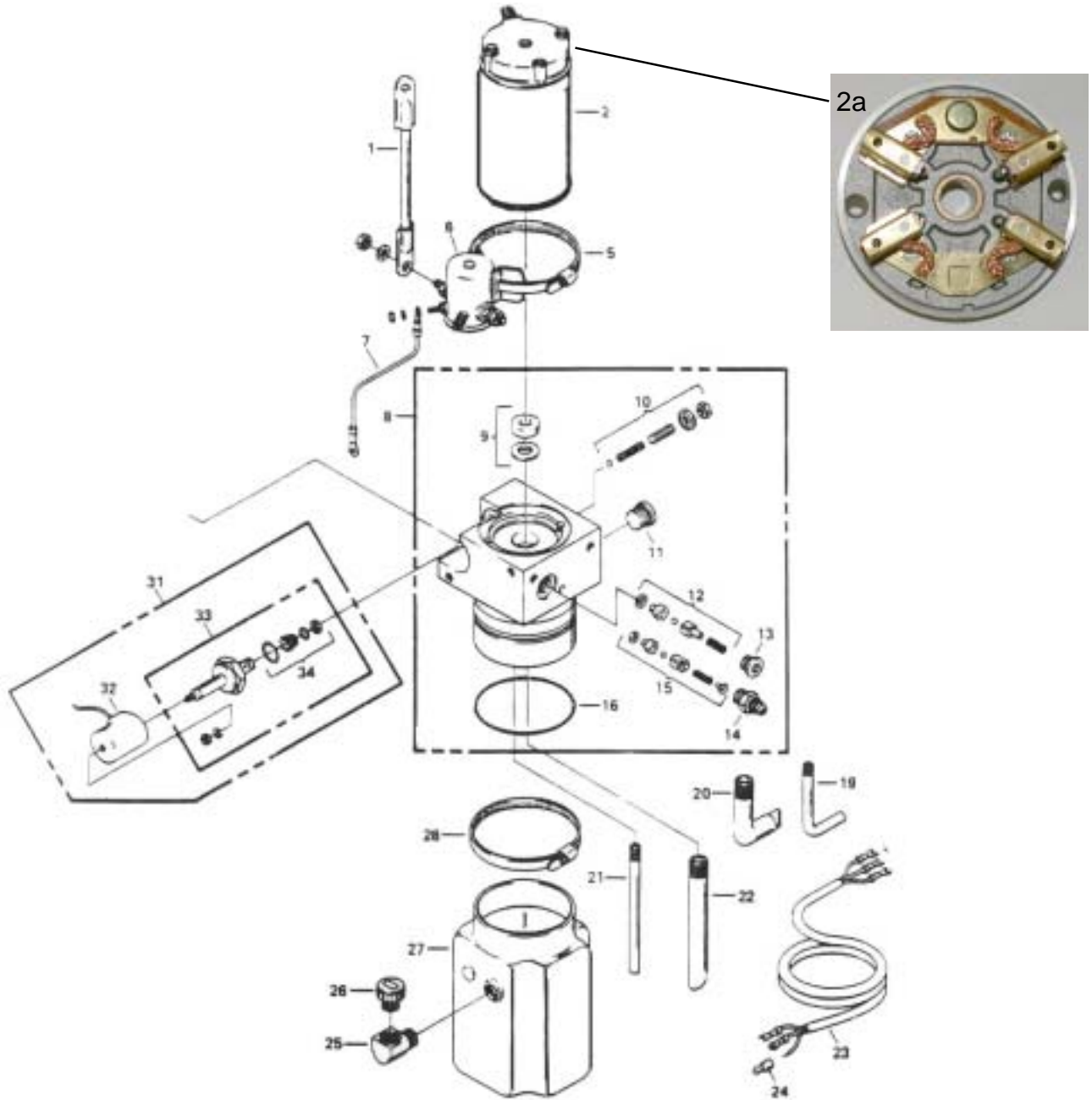

ITEM NO.	PART NUMBER	DESCRIPTION
2.	MP-08053	Electric Motor, 12V
2a.	MP-08684	Brush Set, 3 brushes & end cap 2001 and before
2a.	MP-08711	Brush Set, 3 brushes & end cap 2002 and after
6.	MP-03335	Solenoid Switch, 4 post, curved (controls up movement)
6.	MP-17744	Solenoid Switch, heavy duty
23.	MP-03773	Cord, Harness, 144" Long
27.	MP-06231	Plastic Reservoir
31.	MP-00488	Electric Valve, (controls down movement)
32.	MP-00496	Coil, 2 way- 2 position

**Call ODB for any part not listed.*

LCT600 Curb Nozzle Assembly- OPTIONAL

03/98 and after

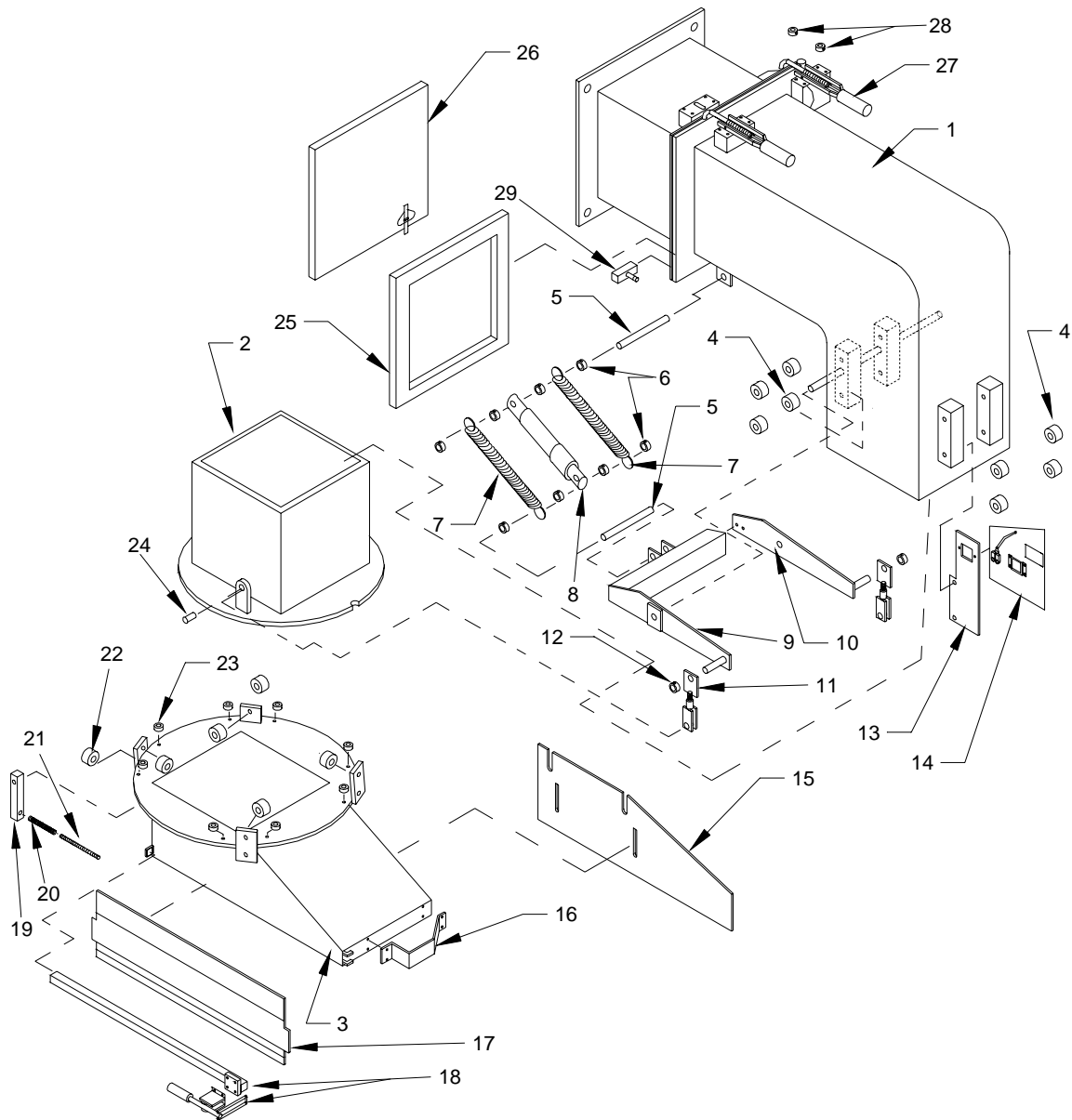

ITEM NO.	PART NUMBER	DESCRIPTION	ITEM NO.	PART NUMBER	DESCRIPTION
1.	LCT672.001	Curb Nozzle Elbow	16.	LCT675.002	Bumper
2.	LCT674	Telescopic Duct	17.	LCT678	Deflector Shield
3.	LCT675.A	Nozzle Foot	18.	LCT678.B	Lock Rod for Shield
4.	LCT685.A	Roller Bearing, 1.75"	19.	LCT688	Adjustment Bar
5.	LCT686	Shaft	20.	LCT689	Adjustment Spring
6.	211106	Set Collar, 5/8"	21.	LCT690	Adjustment Threaded Rod
7.	LCT679	Spring	22.	LCT685	Roller Bearing, 1.75"
8.	LCT680	Hydraulic Cylinder	23.	LCT676	Roller Bearing, 1"
9.	LCT677	Leverage Arm, RH	24.	LCT667	Clevis Pin, 1"
10.	LCT677A	Leverage Arm, LH	25.	LCT672.002	Gasket
11.	LCT687	Clevis Arm	26.	LCT672.004	Safety Cover
12.	211107	Set Collar, 3/4"	27.	LCT672.003	Clamp
13.	LCT665	Up/Dwn Switch Bracket	28.	LCT672.005	Set Collar for Hinge Pin
14.	LCT616.611A	Up/Down Switch	29.	LCT690.601.A	Limit Switch
15.	LCT675.001	Front Deflector			



CAUTION

DO NOT ATTEMPT TO OPERATE
OR REPAIR
THE LEAF COLLECTOR WITHOUT FIRST
READING AND UNDERSTANDING THIS
MANUAL

IF YOU HAVE ANY QUESTIONS CONCERNING THE
INSTALLATION OR OPERATION OF THIS UNIT, PLEASE CALL
ODB FOR ASSISTANCE BEFORE ATTEMPTING TO REPAIR OR
OPERATE THE UNIT.

IMPROPER USE OF ANY MACHINE CAN
RESULT IN SERIOUS INJURY!

STUDY AND FOLLOW ALL SAFETY
PRECAUTIONS BEFORE OPERATING OR
REPAIRING UNIT

THIS MANUAL IS AN INTEGRAL PART OF THE LEAF COLLECTOR AND
SHOULD BE KEPT WITH THE UNIT WHEN IT IS SOLD.

ODB COMPANY
5118 Glen Alden Drive
Richmond, VA 23231
800-446-9823

